

# elco

# HEATING CATALOGUE



**ErP**   
Energy-related Products



# elco

# HEATING CATALOGUE



**THE COMPANY** \_\_\_\_\_ p. 4

**RANGE OVERVIEW** \_\_\_\_\_ p. 14

**GAS BURNERS** \_\_\_\_\_ p. 20

**DUAL FUEL BURNERS** \_\_\_\_\_ p. 126

**LIGHT OIL BURNERS** \_\_\_\_\_ p. 152

**MODULATION KIT** \_\_\_\_\_ p. 180

**OPTIONS** \_\_\_\_\_ p. 182



# CUTTING-EDGE BURNERS FOR HEATING AND INDUSTRIAL APPLICATIONS

## INNOVATION

---

Since its foundation in 1928, ELCO has always been a specialist in burners conception and manufacturing. By linking a strong innovative ability to a continued developing drive, ELCO has designed high performing and reliable burners as well as corresponding services throughout the years, and is today one of the leaders in the field of combustion technology.

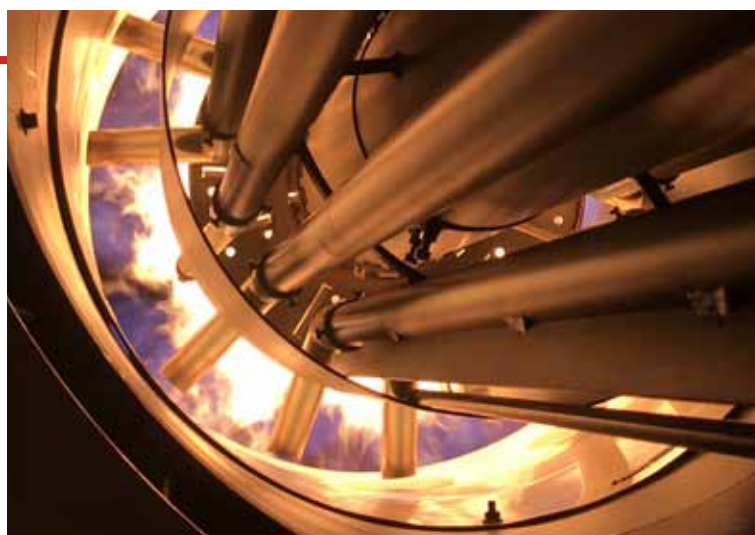

## OUR MISSION

---

ELCO always looks for the best technologies and continues to develop new ones to improve the efficiency of its solutions.

Our R&D Laboratories are committed to develop innovative technological solutions allowing to:

- optimise the running of the installations lowering costs;
- offer service friendly products easy to maintain;
- preserve the environment lowering acoustic and pollutant emissions.



## OUR KNOWLEDGE

---

Your contacts at ELCO and its partners are recognised experts with years of experience. Our worldwide support starts from concept creation to planning, design and project management up to commissioning and on-going operation of the plant throughout its life cycle.

As an ELCO customer, you can rely on your installation to perform reliably. Our guarantee is backed up by a service that sets standards in our field.



## PROFESSIONAL STAFF

---

Taking advantage of a staff composed of technicians and engineers with a long experience, ELCO is able to provide professional support to the customer in order to define together the best solution and to develop and manage the project through its entire life-cycle.

ELCO Service activities define the standards in the market and each customer can rely on high performance and reliable products.



## SOLUTIONS FOR EVERY NEED

---

A long presence in the international market has allowed ELCO to build a strong experience in burner customization and to develop products that are able to guarantee reliability, quality and high performance even in the most extreme working conditions.





## TECHNICAL ASSISTANCE

For safe and efficient operation of your burner system it is very important that the burner is commissioned by a competent person. The combustion will be optimally adjusted over the whole power range of the burner, and all the safety devices will be tested. To keep your installation in good conditions, it is important to maintain the burner periodically. It is also very important to inspect all the safety devices to ensure that your system operates safely. Fortunately, you can rely on the professional services of ELCO which can perform this service for you.



## BURNER ACADEMY

In order to respond to the needs of our customers we created a Burner Academy, a real training school where the knowledge of our technicians is passed on to our trainees. We provide the opportunity for boiler room personnel, operators and engineers to attend a series of training sessions carried out on our test bench by highly qualified instructors, who hold the courses in English, German, French, Italian and Dutch language.

The Burner Academy uses various training locations where boilers are installed and where people can be trained in theory and in practice. We offer courses at different levels and also the possibility to handle all your needs in a customer-specific training.



## RELIABLE SUPPLY OF SPARE PARTS

Spare parts have always had a great importance inside the ELCO world. Considering the high amount of parts involved in every single product, some of these parts might naturally need to be replaced. ELCO can count on an International network offering original spare parts in order to guarantee the highest quality, reliability and safe continued operation of the appliance.

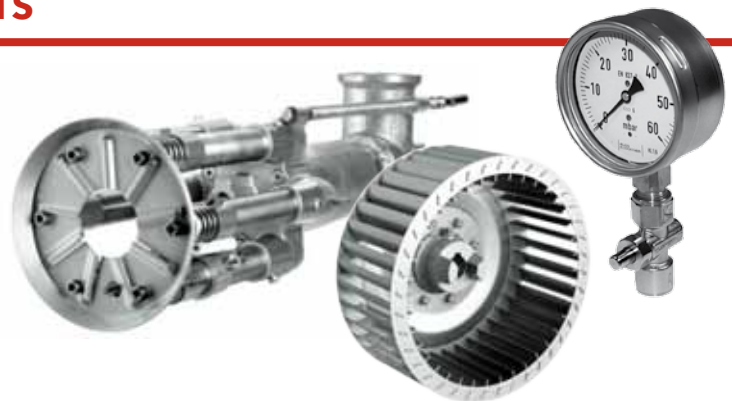

## WORLDWIDE NETWORK

Capitalising on more than 90 years of work experience, ELCO has been capable to build up loyal partnerships and today can count on reliable Partners all over the World.

Combining an instinctively global perspective with a genuinely multicultural approach ELCO today offers you skilled and experienced experts available in more than 70 Countries.

### In Europe

3 production plants  
6 commercial branches  
Strong commercial presence through a network of reliable dealers and partners

### Worldwide

2 Sales Offices in Russia and China  
Distribution in over 70 Countries



### Service Network

In Western Europe, ELCO has a well organised service network. Outside Western Europe ELCO uses a network of partners, consisting of well-trained local engineers, to carry out its service operations. These technicians are able to perform both commissioning and local service and they do it in a very professional and efficient way.

## ELCO ON THE WEB

We are constantly looking forward to provide to our customers new technologies, products and services. Stay always up to date on the latest news from the ELCO World visiting our website:

[www.elco-burners.com](http://www.elco-burners.com)

Navigate to explore the ELCO proposal and choose the perfect product to fit your needs, and follow us to know more about our new activities and projects.

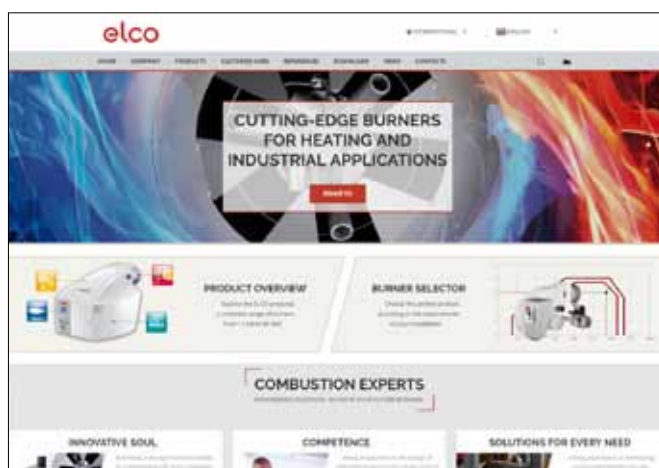

## OUR PRODUCT RANGE

Our experience at combustion technology available in a complete range of burners from 11 kW to 80 MW:

### Monoblock range:



**VECTRON**  
11 - 2300 kW  
■ Gas  
■ Light oil  
■ Dual fuel



**PROTRON**  
15 - 550 kW  
■ Gas  
■ Light oil



**NEXTRON**  
250 - 11200 kW  
■ Gas  
■ Light oil  
■ Dual fuel



**EK EVO**  
250 - 13000 kW  
■ Gas  
■ Light oil  
■ Dual fuel



**N**  
1300 - 22000 kW  
■ Gas  
■ Light oil  
■ Dual fuel



**HO-TRON**  
68 - 17000 kW  
■ Heavy oil



**GHO-TRON**  
414 - 17000 kW  
■ Heavy oil  
■ Dual fuel

### Duoblock range:



**D-TRON**  
230 - 34000 kW  
■ Gas  
■ Light oil  
■ Gas / light oil  
■ Heavy oil  
■ Gas / heavy oil

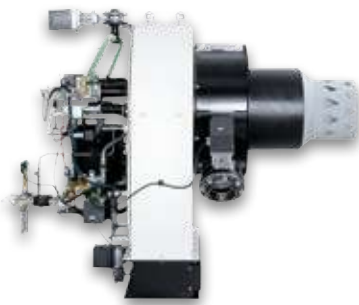

**EK-DUO**  
600 - 16000 kW  
■ Gas  
■ Light oil  
■ Dual fuel



**RPD**  
500 - 80000 kW  
■ Gas  
■ Light oil  
■ Gas / light oil  
■ Heavy oil  
■ Gas / heavy oil



# ELCO SYSTEMS AND TECHNOLOGIES

To constantly improve its products, ELCO is committed to develop innovative technological solutions allowing to optimise the running of the installations, to ease technicians work, and naturally to preserve the environment. In order to provide quick responses to its market's demands, the range of ELCO burners is entirely conceived around a consistent combination of Systems.



## MDE2 System

Permanent communication of information easy to use

Equipped with the MDE2 System, the universal language Elcogram and the 5-button keyboard, ELCO burners adjust themselves and constantly communicate to the technicians and operators:

- real time information about each ignition and during the running;
- statistical information about the burner operations recorded during the whole year before the maintenance operations.

"ELCOGRAM":  
universal language  
based on symbols  
and numerical data

Display shows  
all information for  
daily operation

Menu-driven burner  
setup and operation  
via keypad





**Elcogram, a universal language**

As ELCO products are distributed worldwide, the company has developed a universal language composed of pictograms and numerical data. The pictograms use the majority of the symbols used on the wiring diagrams which are recognised and understood by all Nations. This ensures that information is easier to read than ever before.



## GEM System

Electronic burner control: high safety and low costs

The use of electronic technologies in burner control systems helps to reduce running costs, improve reliability of operation and lower pollutant emissions. The electronic combustion manager used on ELCO burners are responsible not only for the burner control (formerly the task of the traditional automatic combustion control unit) but also for fuel/air regulation. Data stored electronically has replaced the mechanical characteristic curve and help to achieve an unprecedented level of precision in air/fuel ratio regulation across the burner's entire control range, a prerequisite for efficient, energy- and cost-saving operation.

The GEM System controls the position of one or more activators simultaneously. The servomotors of the air flow and oil components are controlled by a microprocessor which contains set points defined for each load curve. An additional advantage of the GEM is that it provides specific information on all the commands and current situation of the overall system: these can be accessed directly or by remote control.

The digital programming is user-friendly, it is carried out through the display of the MDE2 System or through a PC by using a simple procedure facilitated by easy instructions in a clear language.

## ELCO SYSTEMS AND TECHNOLOGIES

---



### AGP System

**An outstanding technology for gas burners**

Developed and produced by ELCO, the AGP System (proportional air-gas) provides:

- perfect stability of the air-gas mixture;
- a constantly high CO<sub>2</sub> content over the whole burner power range;
- precise control of air excess, which is important for high-efficiency operation, in particular for condensing generators.

The AGP measures: the gas pressure downstream of the gas train, the air pressure behind the flame holder and the furnace backpressure.

Any variations in the three pressures are immediately and simultaneously recorded by the system which automatically restores the correct gas/combustion air ratio.

AGP maintains a constant gas/combustion air ratio even in the presence of:

- positive or negative variations in the gas pressure;
- variations in air flow due to changes in the electrical supply voltage or fouling of the ventilation system;
- variations in the furnace and flue draft pressure on start-up and during load changes.



### Variatron

**Speed regulation: noise reduction and energy saving**

To improve the performance of heating or industrial systems, ELCO applies Variatron (fan speed control). Conventionally, the air in modulating burners is regulated by an air flap. In the partial load range, a large amount of the air pressure generated by the ventilator goes to waste.

With speed regulation, the speed of the combustion-air fan is varied continuously depending on the burner output required. Full speed is reached only at maximum burner output. In the predominant partial load range, lower speed translates into significant reductions in power consumption and noise emissions. The Variatron operates in step with the air damper both with the GEM System and with the AGP System, which guarantees a combustion with minimum air excess by continuously monitoring all operating conditions.

Application of the Variatron to ELCO burners results in:

- electrical consumption savings in the order of 50%;
- turndown ratio of up to 1:10, resulting in perfect adaptation to system requirements and improvement in average seasonal efficiency, in particular with condensing or low-temperature boilers or specific processes;
- silent start-up and average overall noise reduction between 2 dB(A) (at maximum power) and 12 dB(A) (at minimum power).



### Low Noise System

**Increase the comfort in-use and protect the environment**

Among all the harmful things that people have to bear with every day life, the most annoying is noise, which is difficult to reduce and expensive to reduce.

This is the reason why ELCO has developed quiet burners both by selecting sound absorbent materials, and by treating each noise sources internally. The main noise comes from the air intake and the air mixing in the fan wheel: all the ELCO burners are equipped with a sound trap on the air intake channel leading to the fan.

This brings the acoustic level to an acceptable value in respect of the environment.

# COMBUSTION TECHNOLOGIES



## Diamond Head Low emissions and reliable operation

The principle of the Diamond Head combustion technology is based on the internal recirculation of the combustion flue gases. These are partially drawn into the base of the flame via triangular openings positioned at the end of the combustion head. The position and geometry of the gas injectors are such that a significant quantity of combustion flue gas is drawn in and rapidly mixed with air and gas at the root of the flame.

This mixture crosses the main reaction area, slowing the combustion, which in turn results in lowering the main flame temperature. The result of this staging combustion is a significant reduction in the formation of thermal nitrogen oxides.

The advantage of this internal recirculation technique is an automatic adjustment to the quantity of recycled combustion flue gases: the volume of the flame is always as low as possible, which has a very minor effect on the nominal power of the generator, unlike external recirculation systems.

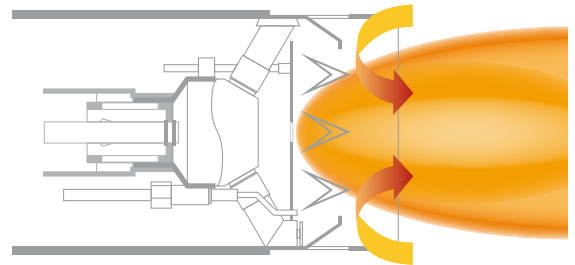

## Free Flame The pinnacle of low-polluting burner engineering

The principle of the Free Flame oil combustion is based on rapid gasification of the fuel by recirculating the combustion gases internally and allows the fuel-air to mix quickly.

Once the fuel has been vaporised, it will burn and stabilise 30 centimetres from the combustion head.

The flame appears to “float freely” hence the name “Free Flame”. The heat absorbed by the gasification oil will cause a significant drop in the flame’s temperature and a decrease in the formation of the thermal nitrogen oxide.

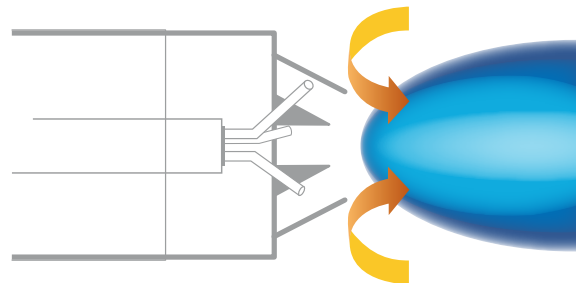

## FGR System Ultra low NOx solutions to reach emissions of less than 30 mg/kWh

ELCO offers a wide range of products which use the external FGR technology to reduce NOx emissions and satisfy even the most stringent regulations.

The principle of external flue gas recirculation consists in sending a mixture of comburent air and flue gas to the combustion head, thus reducing the NOx emissions. The gases are mixed upline of the combustion process by the burner fan (for mono-block units) or by the external fan (in case of duoblock burners). This technology enables ELCO to guarantee emissions of less than 30 mg/kWh, a value which is hard to obtain with conventional combustion systems, and offer cutting-edge products which satisfy the requirements of any current regulations.

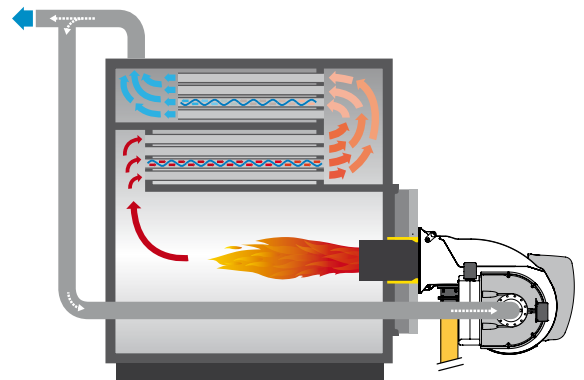

## WORLDWIDE REFERENCES

ELCO has been chosen as the ideal partner from worldwide companies to design installations where technical specifications and environmental conditions require a specific design. In the next pages you will find a selection of our international references.



**Beijing, China**  
4x RPD 100 G-EU



**Sergiev Posad, Russia**  
2x N6.2900 G-R  
2x N7.3600 G-R



**Stuttgart, Germany**  
1x EK-DUO 2.550 GL-EUF  
2x EK-DUO 2.700 GL-EUF



**Beijing, China**  
2x N10.16000 G-EU2 FGR



**Stavanger, Norway**  
2x EK-DUO 3.1600 G-E





**Altchemnitz, Germany**  
**6x N11.22000 G-EU1**

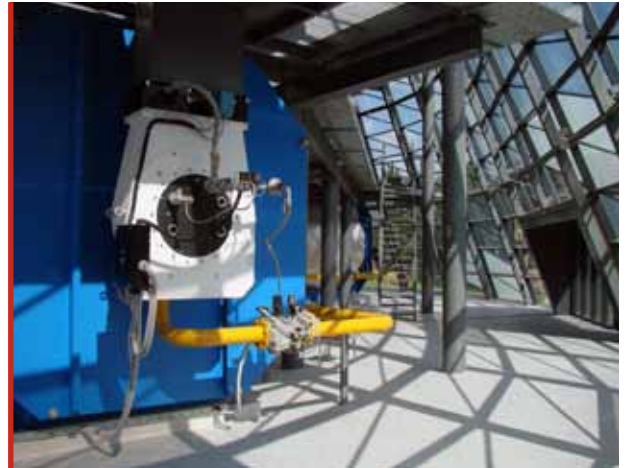

**Saint Petersburg, Russia**  
**1x EK-DUO 4.1600 G-EU2**



**Seoul, South Korea**  
**7x N8.7100 G-EU3**



**Beijing, China**  
**1x EK EVO 8.5800 G-EU3 FGR**  
**2x EK EVO 8.7100 G-EU3 FGR**



**Tianjin, China**  
**1x RPD130 G-EU1 FGR**



**Epe, Netherlands**  
**1x EK EVO 7.4500 G-EF3**



**Designation**

**Burner body**

**OPERATION TYPE**

- = 1 stage
- P** = 1 stage standard with pre-heater (light oil)
- D** = 2 stages
- DP** = 2 stage progressive/modulating pneumatic Low NOx (gas) / 3 stages (light oil)
- DP R** = 2 stage progressive/modulating pneumatic
- V** = 2 stage progressive/modulating pneumatic + fan speed control
- VD** = 2 stages PWM Low NOx (light oil)
- M** = 2 stage progressive/modulating electronic Low NOx
- M R** = 2 stage progressive/modulating electronic
- M V** = 2 stage progressive/modulating electronic Low NOx + fan speed control
- M V R** = 2 stage progressive/modulating electronic + fan speed control

**PLATFORM**

From **1** to **6**  
(**05-06** for VGL only)

**SIZE**

Max power (kW)

**VG3.290 M E /TC KN 6H**

**FUEL AND COMBUSTION TYPE**

- G** = Natural gas
- GL** = Dual fuel (natural gas/light oil)
- L** = Light oil standard
- B** = Light oil Low NOx Blue flame
- E** = Light oil Low NOx Yellow flame

**ERP COMPLIANCE**

- = not compliant
- E** = compliant  
(for gas only)

**ADDITIONAL EQUIPMENT**

- /TC** = Tightness control
- /PED** = PED equipped
- /FGR** = FGR equipped

**HEAD LENGTH**

- KN** = short
- KM** = medium
- KL** = long

**ELECTRICAL SUPPLY**

- = 230V / 50Hz
- 6H** = 230V / 60Hz
- 110** = 110-120 V/50-60 Hz

**Gas train**

**VALVE MANUFACTURER**

- d** = Dungs
- s** = Siemens
- k** = Kromschröder
- h** = Honeywell

**VALVE NOMINAL DIAMETER**

1/2" ... 2" or 50...100 mm

**GAS TRAIN CONNECTION DIAMETER**

Rp1/2" ... Rp2" (when threaded) or DN50...100 (when flanged)

**d335 - 1"1/2 - Rp2" /TC 110**

**OPERATION TYPE**

- 1** = 1 stage
- 2** = 2 stages
- 3** = Pneumatic
- 4** = Electronic

**SERIES**

Progressive number

**ADDITIONAL EQUIPMENT**

- /TC** = Tightness control

**ELECTRICAL SUPPLY**

- = 230V / 50Hz
- 110** = 110-120 V/50-60 Hz

**Other burner versions**

- 60** 60 Hz version
- TC** Version with tightness control
- V<sub>cont</sub>** Versions for continuous ventilation and post-ventilation
- PED** PED version for continuous operation
- ErP** ErP compliant

## Gas range

### Main features

- Fuels:
  - natural gas (G20/G25,  $H_u = 8,83...10,35 \text{ kWh/m}^3$ );
  - LPG (G31,  $H_u = 25,89 \text{ kWh/m}^3$ ).
- Cubic type architecture allowing optimal accessibility, maximum compactness, minimum weight.
- Complete electrical equipment in the body of the burner with MDE2 System and display: this ensures that information is easier to read than ever before, constantly giving real-time information to professional operators, during the commissioning, the operation and at each operation cycle.
- Quiet ventilation and reduced electrical consumption.
- Closing of the air flap at burner shut-down.
- Maintenance operation are simplified: the combustion parts can be quickly removed, easily cleaned and, even when they are disassembled, they easily get back to their position after all the servicing work.
- Gas train factory assembled and tested for tightness and electrical security.
- All products are in compliance with EN676 European standards and with the following directives:
  - 2014/35/EU Low Voltage Directive
  - 2014/30/EU EMC Directive
  - 2016/426/EU Gas Appliance Regulation
  - 2006/42/EC Machine Directive
- All products up to VG4.440 are in compliance with ErP Directive



### ONE STAGE Low NOx

VG1.40 E /TC	60	VENT	ErP	15 ... 41 kW						p. 20
VG1.55 E /TC	60	VENT	ErP	35 ... 55 kW						p. 20
VG1.105 E /TC	60	VENT	ErP	50 ... 105 kW						p. 20
VG2.140 E	60	VENT	ErP	80 ... 140 kW						p. 22
VG2.205 E	60	VENT	ErP	130 ... 205 kW						p. 22

### TWO STAGES Low NOx

VG1.105 D E	60	VENT	ErP	37 ... 105 kW						p. 24
VG2.120 D E	60	VENT	ErP	40 ... 120 kW						p. 26
VG2.160 D E	60	VENT	ErP	50 ... 160 kW						p. 26
VG2.205 D E	60	VENT	ErP	65 ... 205 kW						p. 26
VG3.290 D E	60	TC	VENT	ErP	95 ... 290 kW					p. 28
VG3.350 D E	60	TC	VENT	ErP	105 ... 350 kW					p. 28
VG4.440 D E	60	TC	VENT	ErP	110 ... 440 kW					p. 32

### TWO STAGE PROGRESSIVE/MODULATING PNEUMATIC Low NOx

VG2.120 DP E	60	VENT	ErP	40 ... 120 kW						p. 36
VG2.160 DP E	60	VENT	ErP	50 ... 160 kW						p. 36
VG2.205 DP E	60	VENT	ErP	65 ... 205 kW						p. 36
VG3.290 DP E	60	TC	VENT	ErP	95 ... 290 kW					p. 38
VG3.350 DP E	60	TC	VENT	ErP	105 ... 350 kW					p. 38
VG4.440 DP E	60	TC	VENT	ErP	110 ... 440 kW					p. 42
VG4.610 DP	60	TC	VENT	130 ... 610 kW						p. 46
VG5.950 DP	60	TC	VENT	170 ... 950 kW						p. 50
VG5.1200 DP	60	TC	VENT	250 ... 1160 kW						p. 50
VG6.1600 DP /TC	60	VENT		300 ... 1600 kW						p. 54
VG6.2100 DP /TC	60	VENT		400 ... 1900 kW						p. 54

## TWO STAGE PROGRESSIVE/MODULATING PNEUMATIC

VG5.950 DP R	60 TC VENT	150 ... 1000 kW		p. 58
VG5.1200 DP R	60 TC VENT	200 ... 1200 kW		p. 58
VG6.1600 DP R /TC	60 VENT	200 ... 1700 kW		p. 62
VG6.2100 DP R /TC	60 VENT	300 ... 2300 kW		p. 62

## TWO STAGE PROGRESSIVE/MODULATING PNEUMATIC Low NOx + fan speed control

VG2.205 V E	VENT ErP	65 ... 205 kW		p. 66
VG3.290 V E	TC VENT ErP	95 ... 290 kW		p. 68
VG3.350 V E	TC VENT ErP	105 ... 350 kW		p. 68
VG4.440 V E	TC VENT ErP	110 ... 440 kW		p. 72
VG4.610 V	TC VENT	130 ... 610 kW		p. 76

## TWO STAGE PROGRESSIVE/MODULATING ELECTRONIC Low NOx

VG2.120 M E /TC	VENT ErP	40 ... 120 kW		p. 80
VG2.160 M E /TC	VENT ErP	50 ... 160 kW		p. 80
VG2.205 M E /TC	VENT ErP	65 ... 205 kW		p. 80
VG3.290 M E /TC	VENT ErP	95 ... 290 kW		p. 82
VG3.350 M E /TC	VENT ErP	105 ... 350 kW		p. 82
VG4.440 M E /TC	VENT ErP	110 ... 440 kW		p. 86
VG4.610 M /TC	VENT	90 ... 610 kW		p. 90
VG5.950 M /TC	VENT PED	160 ... 900 kW		p. 94
VG5.1200 M /TC	VENT PED	160 ... 1160 kW		p. 94
VG6.1600 M /TC	VENT PED	240 ... 1600 kW		p. 98
VG6.2100 M /TC	VENT PED	260 ... 1900 kW		p. 98

## TWO STAGE PROGRESSIVE/MODULATING ELECTRONIC Low NOx + fan speed control

VG5.950 M V /TC	VENT PED	160 ... 900 kW		p. 102
VG5.1200 M V /TC	VENT PED	160 ... 1160 kW		p. 102
VG6.1600 M V /TC	VENT PED	240 ... 1600 kW		p. 106
VG6.2100 M V /TC	VENT PED	260 ... 1900 kW		p. 106

## TWO STAGE PROGRESSIVE/MODULATING ELECTRONIC

VG5.950 M R /TC	VENT PED	150 ... 1000 kW		p. 110
VG5.1200 M R /TC	VENT PED	200 ... 1200 kW		p. 110
VG6.1600 M R /TC	VENT PED	200 ... 1700 kW		p. 114
VG6.2100 M R /TC	VENT PED	300 ... 2300 kW		p. 114

## TWO STAGE PROGRESSIVE/MODULATING ELECTRONIC + fan speed control

VG5.950 M V R /TC	VENT PED	150 ... 1000 kW		p. 118
VG5.1200 M V R /TC	VENT PED	200 ... 1200 kW		p. 118
VG6.1600 M V R /TC	VENT PED	200 ... 1700 kW		p. 122
VG6.2100 M V R /TC	VENT PED	300 ... 2300 kW		p. 122

## Dual fuel range

### Main features

- Fuels:
  - natural gas (G20/G25,  $H_u = 8,83...10,35 \text{ kWh/m}^3$ );
  - light oil (viscosity  $6 \text{ mm}^2/\text{s}$  at  $20^\circ\text{C}$ ,  $H_u = 11,86 \text{ kWh/kg}$ ).
- Cubic type architecture allowing optimal accessibility, maximum compactness, minimum weight.
- Complete electrical equipment in the body of the burner with MDE2 System and display: this ensures that information is easier to read than ever before, constantly giving real-time information to professional operators, during the commissioning, the operation and at each operation cycle.
- Maintenance operation are simplified: the combustion parts can be quickly removed, easily cleaned and, even when they are disassembled, they easily get back to their position after all the servicing work.
- Quiet ventilation and reduced electrical consumption.
- Closing of the air flap at burner shut-down.
- Gas train factory assembled and tested for tightness and electrical security.
- All products are in compliance with EN676 and EN267 European standards and with the following directives:
  - 2014/35/EU Low Voltage Directive
  - 2014/30/EU EMC Directive
  - 2016/426/EU Gas Appliance Regulation
  - 2006/42/EC Machine Directive



### ONE STAGE in gas and in oil

Model	Vent	Power Range (kW)	Graph Range (kW)	Page
VGL2.120		35 ... 120 kW	0 - 120	p. 126
VGL2.210		100 ... 190 kW	100 - 190	p. 126

### TWO STAGES in gas and in oil

Model	Vent	Power Range (kW)	Graph Range (kW)	Page
VGL3.290 D		95 ... 290 kW	100 - 290	p. 128
VGL3.360 D		120 ... 360 kW	120 - 360	p. 128

### TWO STAGE PROGRESSIVE/MODULATING PNEUMATIC in gas / TWO STAGES in oil

Model	Vent	Power Range (kW)	Graph Range (kW)	Page
VGL4.460 DP		168 ... 460 kW	168 - 460	p. 132
VGL4.610 DP		190 ... 610 kW	190 - 610	p. 132

### TWO STAGE PROGRESSIVE/MODULATING ELECTRONIC in gas / THREE STAGES in oil

Model	Vent	Power Range (kW)	Graph Range (kW)	Page
VGL5.700 M /TC		200 ... 700 kW	200 - 700	p. 136
VGL5.1000 M /TC		240 ... 1000 kW	240 - 1000	p. 136
VGL6.1600 M /TC		300 ... 1600 kW	300 - 1600	p. 140
VGL6.2100 M /TC		480 ... 2050 kW	480 - 2050	p. 140

### TWO STAGE PROGRESSIVE/MODULATING ELECTRONIC + fan speed control in gas / THREE STAGES in oil

Model	Vent	Power Range (kW)	Graph Range (kW)	Page
VGL5.700 M V /TC		200 ... 700 kW	200 - 700	p. 144
VGL5.1000 M V /TC		240 ... 1000 kW	240 - 1000	p. 144
VGL6.1600 M V /TC		300 ... 1600 kW	300 - 1600	p. 148
VGL6.2100 M V /TC		480 ... 2050 kW	480 - 2050	p. 148

## Light oil range

### Main features

- Fuel: light oil (viscosity 6 mm<sup>2</sup>/s at 20°C, H<sub>u</sub> = 11,86 kWh/kg).
- Cubic type architecture allowing optimal accessibility, maximum compactness, minimum weight.
- Complete electrical equipment in the body of the burner with MDE2 System and display: this ensures that information is easier to read than ever before, constantly giving real-time information to professional operators, during the commissioning, the operation and at each operation cycle.
- Quiet ventilation and reduced electrical consumption.
- Closing of the air flap at burner shut-down.
- Maintenance operation are simplified: the combustion parts can be quickly removed, easily cleaned and, even when they are disassembled, they easily get back to their position after all the servicing work.
- All products are in compliance with EN267 European standards and with the following directives:
  - 2014/35/EU Low Voltage Directive
  - 2014/30/EU EMC Directive
  - 2006/42/EC Machine Directive
- All products up to VL4.440 D are in compliance with ErP Directive



### ONE STAGE Low NOx Yellow Flame

Model	ErP	Power Range (kW)	0	20	40	60	80	100 kW	Page
VE1.34	Yes	16 ... 34 kW			█				p. 152
VE1.50	Yes	28 ... 50 kW				█			p. 152
VE1.75	Yes	44 ... 75 kW					█		p. 152

### TWO STAGES Low NOx Yellow Flame

Model	ErP	Power Range (kW)	0	50	100	150	200	250 kW	Page
VE2.100 D	Yes	50 ... 100 kW			█				p. 154
VE2.150 D	Yes	65 ... 150 kW				█			p. 154

### ONE STAGE Low NOx Blue Flame







Model	ErP	Power Range (kW)	0	10	20	30	40	50 kW	Page
VB1.20	Yes	11 ... 20 kW			█				p. 156
VB1.24	Yes	14 ... 24 kW				█			p. 156
VB1.28	Yes	20 ... 28 kW					█		p. 156
VB1.30	Yes	22 ... 30 kW						█	p. 156
VB1.35	Yes	25 ... 35 kW						█	p. 156

### TWO STAGES PWM Low NOx Blue Flame

Model	ErP	Power Range (kW)	0	20	40	60	80	100 kW	Page
VB2.38 VD	Yes	22 ... 38 kW			█				p. 158
VB2.45 VD	Yes	25 ... 45 kW				█			p. 158
VB2.54 VD	Yes	32 ... 54 kW					█		p. 158
VB2.66 VD	Yes	40 ... 66 kW						█	p. 158
VB2.77 VD	Yes	45 ... 77 kW						█	p. 160
VB2.85 VD	Yes	48 ... 85 kW						█	p. 160
VB2.95 VD	Yes	52 ... 95 kW						█	p. 160

















ONE STAGE with pre-heater

VL1.40 P	 	18 ... 40 kW		p. 162
VL1.55 P	 	30 ... 55 kW		p. 162





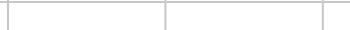

























0                      20                      40                      60                      80                      100 kW

ONE STAGE

VL1.42	 	20 ... 42 kW		p. 162
VL1.55	 	30 ... 55 kW		p. 162
VL1.105	 	45 ... 105 kW		p. 162
VL2.140	 	80 ... 140 kW		p. 164
VL2.200	 	130 ... 200 kW		p. 164















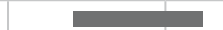

0                      50                      100                      150                      200                      250 kW

TWO STAGES

VL2.120 D	 	60 ... 120 kW		p. 166
VL2.160 D	 	80 ... 160 kW		p. 166
VL2.210 D	 	100 ... 210 kW		p. 166
VL3.290 D	 	130 ... 290 kW		p. 168
VL3.360 D	 	170 ... 360 kW		p. 168
VL4.440 D	 	180 ... 440 kW		p. 168
VL4.460 D	 	180 ... 460 kW		p. 170
VL4.610 D	 	195 ... 610 kW		p. 170
VL5.950 D	 	260 ... 950 kW		p. 172
VL5.1200 D	 	400 ... 1186 kW		p. 172

0                      250                      500                      750                      1000                      1250 kW

THREE STAGES

VL4.460 DP	 	180 ... 460 kW		p. 174
VL4.610 DP	 	195 ... 610 kW		p. 174
VL5.950 DP	 	260 ... 950 kW		p. 176
VL5.1200 DP	 	400 ... 1186 kW		p. 176
VL6.1600 DP	 	320 ... 1600 kW		p. 178
VL6.2100 DP	 	400 ... 2080 kW		p. 178

0                      500                      1000                      1500                      2000                      2500 kW

**VG1.40 E, VG1.55 E, VG1.105 E**

15 ... 105 kW  
1 stage (ErP compliant)

- **Fuels:** natural gas (G20/G25,  $H_u = 8,83 \dots 10,35 \text{ kWh/m}^3$ ); LPG (G31,  $H_u = 25,89 \text{ kWh/m}^3$ )
- **Emissions:** compliant with ErP Directive
- **Protection level:** IP 21



**TECHNICAL DATA**

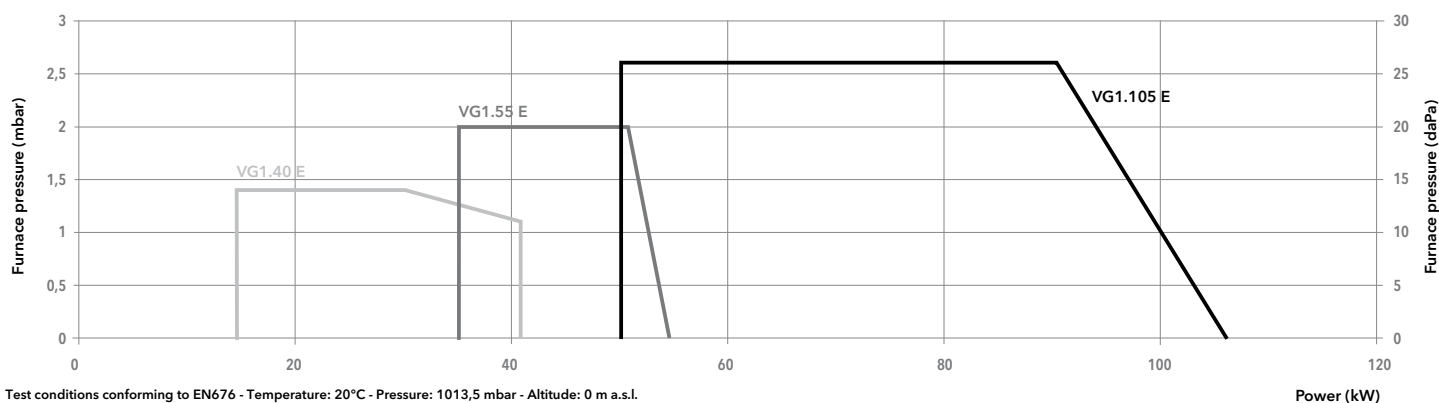

Test conditions conforming to EN676 - Temperature: 20°C - Pressure: 1013,5 mbar - Altitude: 0 m a.s.l.

Model	VG1.40 E /TC		VG1.55 E /TC		VG1.105 E /TC			
Operation range	15 - 41 kW		35 - 55 kW		37 - 105 kW			
Gas pressure	20 - 100 mbar		20 - 100 mbar		20 - 360 mbar			
Control box / flame detection	TCG1... / ionization		TCG1... / ionization		TCG1... / ionization			
Fan motor	230 V - 50 Hz - 85 W		230 V - 50 Hz - 85 W		230 V - 50 Hz - 85 W			
Electrical consumption (max/min/stand-by)	119 W / 137 W / 3 W		129 W / 131 W / 3 W		196 W / 212 W / 3 W			
Acoustic level (LpA)	55 dB(A)		55 dB(A)		61 dB(A)			
CE certificate	0476 CT 2423		0476 CT 2423		0476 CT 2423			
Head lenght	KN	KL	KN	KL	KN	KL		
Complete burner code	VR4625 MB-DLE 407	h3/8"-Rp1/2"/TC d3/4"-Rp3/4"/TC	<b>3866346</b>	<b>3836506</b>	<b>3836347</b>	<b>3836517</b>	- <b>3836348</b>	- <b>3836518</b>

**OTHER AVAILABLE VERSIONS**

- 60 60 Hz version
- Ver Versions for continuous ventilation and post-ventilation

**SCOPE OF SUPPLY**

The burner is delivered in its package complete with:

- 1 gas connection flange
- 1 compact gas train with gas filter; the gas filter is built-in for threaded valves (up to 2") and separated for flanged ones (DN65/80/100)
- 1 burner flange with insulation
- 1 bag containing installation fittings
- 1 bag containing technical documentation (instruction manual, technical data, electrical diagram, exploded view and spare parts list)



**DIMENSIONS (mm)**

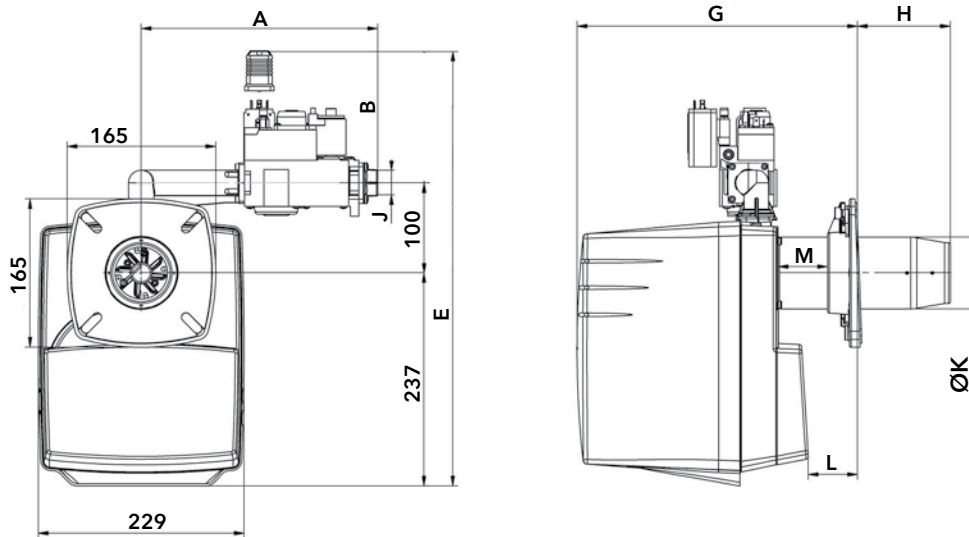

Model	A	B	E	G		H		J	Ø K	L		M
				KN	KL	KN	KL			min	max	
VG1.40/55 E	263	147	484	297...337	297...387	70...110	70...200	Rp1/2"	80	21	61	48
VG1.105 E	282	140	477	300...355	300...390	70...138	70...228	Rp3/4"	90	15	83	52

**Connecting flange**

Model	Øa (mm)	b (mm)	c	d
VG1.40/55 E	85-104	150-170	M8	45°
VG1.105 E	95-104	150-170	M8	45°

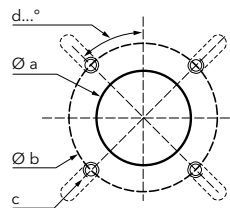

**PACKAGING**

The burner is delivered in 1 single package containing all components

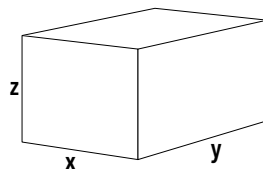

Burner	Dimensions (mm)			Gross weight (kg)
	X	Y	Z	
VG1.40 E	300	260	650	12
VG1.55 E	300	260	650	12
VG1.105 E	300	260	650	12

**VG2.140 E, VG2.205 E**

80 ... 205 kW  
1 stage (ErP compliant)

- **Fuels:** natural gas (G20/G25,  $H_u = 8,83...10,35 \text{ kWh/m}^3$ );  
LPG (G31,  $H_u = 25,89 \text{ kWh/m}^3$ )
- **Emissions:** compliant with ErP Directive
- **Protection level:** IP 21



**TECHNICAL DATA**

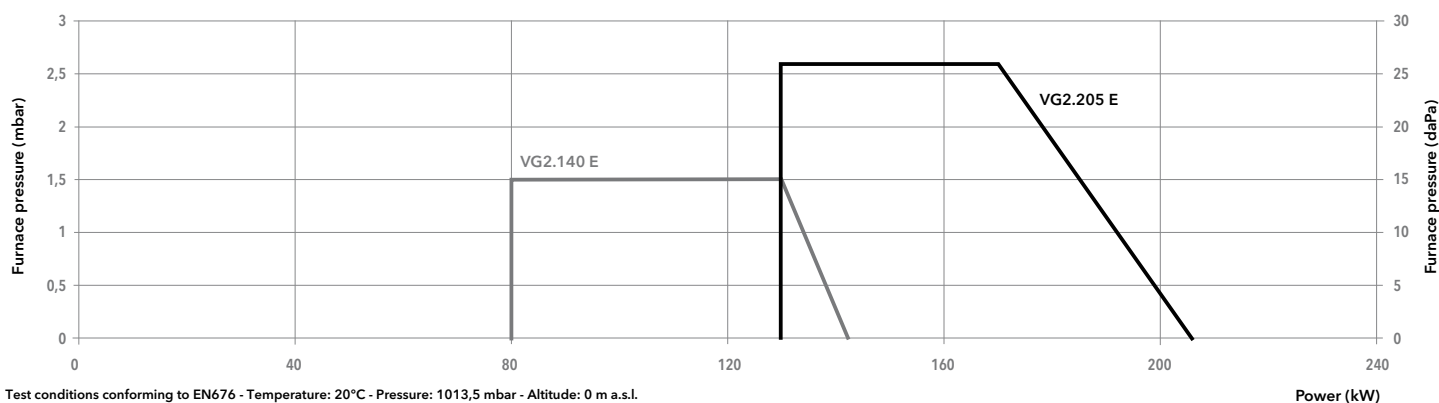

Test conditions conforming to EN676 - Temperature: 20°C - Pressure: 1013,5 mbar - Altitude: 0 m a.s.l.

Model	VG2.140 E		VG2.205 E	
Operation range	80 - 140 kW		130 - 205 kW	
Gas pressure	20 - 360 mbar		20 - 360 mbar	
Control box / flame detection	TCG1... / ionization		TCG1... / ionization	
Fan motor	230 V - 50 Hz - 100 W		230 V - 50 Hz - 130 W	
Electrical consumption (max/min/stand-by)	270 W / 230 W / 3 W		302 W / 267 W / 3 W	
Acoustic level (LpA)	62 dB(A)		65 dB(A)	
CE certificate	0476 CT 2423		0476 CT 2423	
Head lenght	KN	KL	KN	KL
Complete burner code	MB-DLE 412 MB-DLE 407	d1"1/4-Rp1"1/4 d3/4"-Rp3/4"	3836351 3836353	3836352 3836354

**OTHER AVAILABLE VERSIONS**

- 60 60 Hz version
- Ver Versions for continuous ventilation and post-ventilation

**SCOPE OF SUPPLY**

The burner is delivered in its package complete with:

- 1 gas connection flange
- 1 compact gas train with gas filter; the gas filter is built-in for threaded valves (up to 2") and separated for flanged ones (DN65/80/100)
- 1 burner flange with insulation
- 1 bag containing installation fittings
- 1 bag containing technical documentation (instruction manual, technical data, electrical diagram, exploded view and spare parts list)

DIMENSIONS (mm)

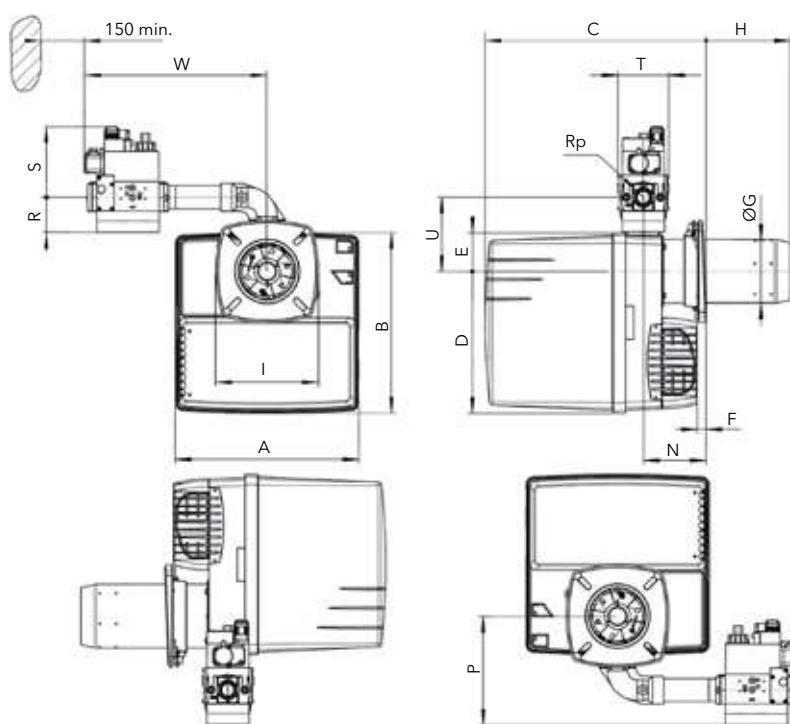

Model	Gas train	A	B	C		D	E	F min	ØG	H		I	N min	P	Rp	R	S	T	U	W
				KN	KL					KN	KL									
VG2.140	d3/4"-Rp3/4"	331	325	398...518	398...638	256	69	15	115	30...150	30...270	185	113	179	3/4"	70	140	120	133	345
VG2.205	d3/4"-Rp3/4"	331	325	398...518	398...638	256	69	15	125	30...150	30...270	185	113	179	3/4"	70	140	120	133	345
VG2.205	d1"1/4-Rp1"1/4	331	325	398...518	398...638	256	69	15	125	30...150	30...270	185	113	188	1"1/4	80	160	145	133	380

Connecting flange

	Øa (mm)	b (mm)	c	d
VG2.140	120-135	150-185	M8	45°
VG2.205	130-145	160-185	M8	45°

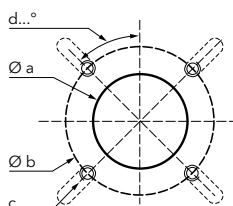

PACKAGING

The burner is delivered in 1 single package containing all components

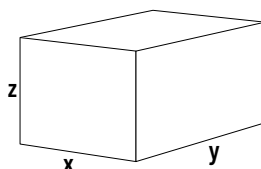

Burner	Dimensions (mm)			Gross weight (kg)
	X	Y	Z	
VG2.140	400	400	760	25
VG2.205	400	400	760	25



**VG1.105 D E**

37 ... 105 kW  
2 stages (ErP compliant)

- **Fuels:** natural gas (G20/G25,  $H_u = 8,83...10,35 \text{ kWh/m}^3$ );  
LPG (G31,  $H_u = 25,89 \text{ kWh/m}^3$ )
- **Emissions:** compliant with ErP Directive
- **Protection level:** IP 21



**TECHNICAL DATA**

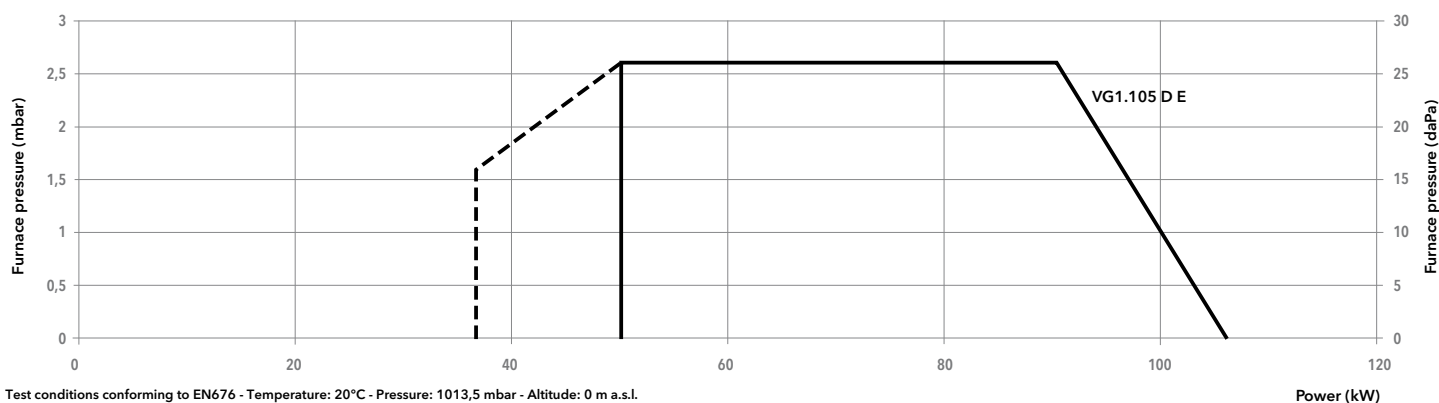

Test conditions conforming to EN676 - Temperature: 20°C - Pressure: 1013,5 mbar - Altitude: 0 m a.s.l.

Model	VG1.105 D	
Operation range	(37) 50 - 105 kW	
Gas pressure	20 - 360 mbar	
Flame detection	Ionization	
Fan motor	230 V - 50 Hz - 85 W	
Electrical consumption (max/min/stand-by)	205 W / 200 W / 3 W	
Acoustic level (LpA)	60,5 dB(A)	
CE certificate	0476 CT 2423	
Head lenght	KN	KL
Complete burner code	MB-ZRDLE 407 d3/4"-Rp3/4" <b>3836355</b>	<b>3836519</b>

**OTHER AVAILABLE VERSIONS**

- 60 60 Hz version
- Ver Versions for continuous ventilation and post-ventilation

**SCOPE OF SUPPLY**

The burner is delivered in its package complete with:

- 1 gas connection flange
- 1 compact gas train with gas filter; the gas filter is built-in for threaded valves (up to 2") and separated for flanged ones (DN65/80/100)
- 1 burner flange with insulation
- 1 bag containing installation fittings
- 1 bag containing technical documentation (instruction manual, technical data, electrical diagram, exploded view and spare parts list)

DIMENSIONS (mm)

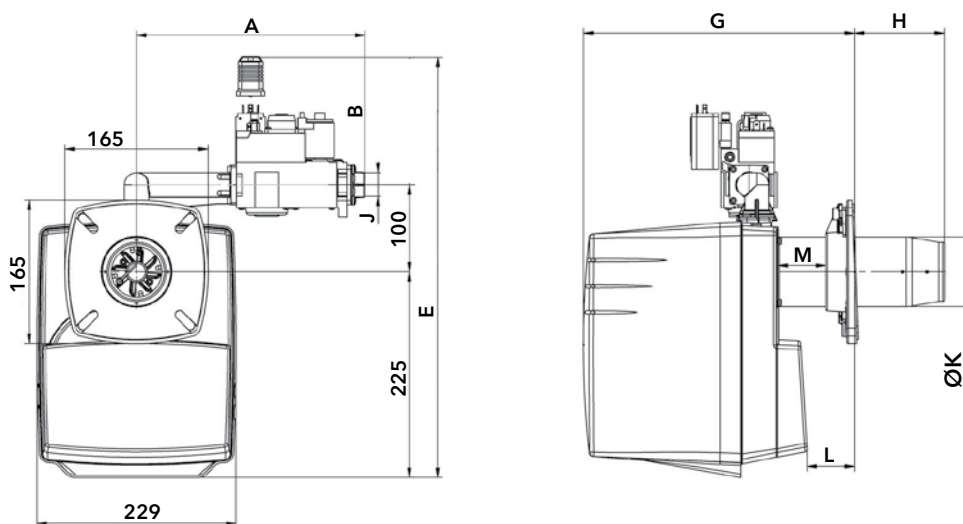

A	B	E	G		H		J	ØK	L		M
			KN	KL	KN	KL			min	max	
290	310	535	300...355	300...390	70...138	70...228	Rp3/4"	90	15	83	52

Connecting flange

Øa (mm)	b (mm)	c	d
95-104	150-170	M8	45°

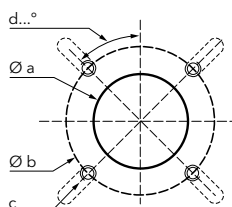

PACKAGING

The burner is delivered in 1 single package containing all components

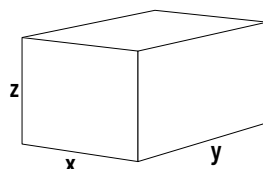

Dimensions (mm)			Gross weight (kg)
X	Y	Z	
300	260	650	12

**VG2.120 D E, VG2.160 D E, VG2.205 D E**

40 ... 210 kW

2 stages (ErP compliant)

- **Fuels:** natural gas (G20/G25,  $H_u = 8,83...10,35 \text{ kWh/m}^3$ );  
LPG (G31,  $H_u = 25,89 \text{ kWh/m}^3$ )
- **Emissions:** compliant with ErP Directive
- **Protection level:** IP 21

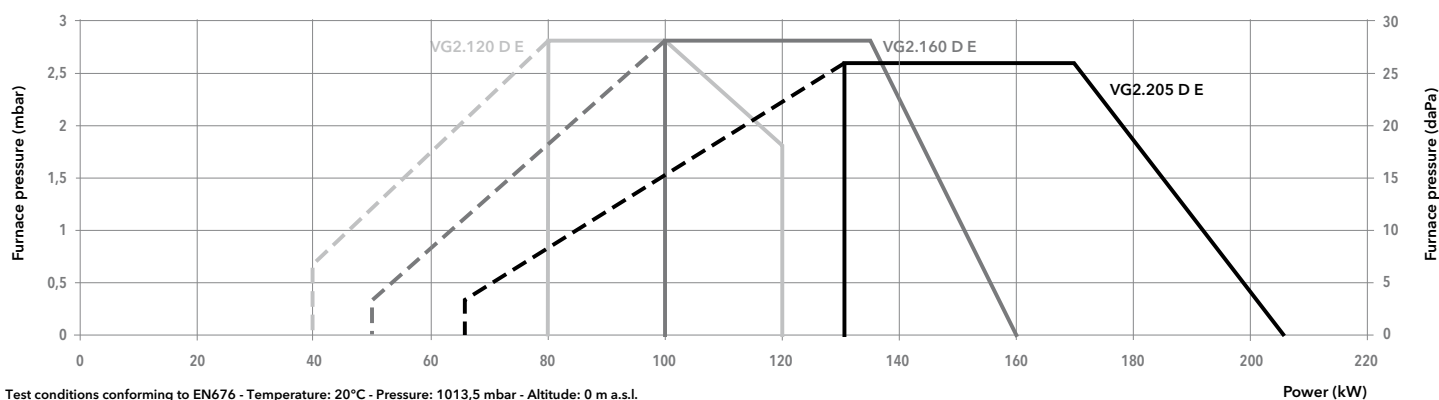
**TECHNICAL DATA**

Model	VG2.120 D E		VG2.160 D E		VG2.205 D E						
Operation range	(40) 80 - 120 kW		(50) 100 - 160 kW		(60) 130 - 205 kW						
Gas pressure	20 - 360 mbar		20 - 360 mbar		20 - 360 mbar						
Control box / flame detection	TCG2... / ionization		TCG2... / ionization		TCG2... / ionization						
Fan motor	230 V - 50 Hz - 100 W		230 V - 50 Hz - 100 W		230 V - 50 Hz - 130 W						
Electrical consumption (max/min/stand-by)	239 W / 358 W / 4 W		285 W / 293 W / 4 W		302 W / 267 W / 4 W						
Acoustic level (LpA)	62 dB(A)		64 dB(A)		65 dB(A)						
CE certificate	0476 CT 2423		0476 CT 2423		0476 CT 2423						
Head lenght	KN	KL	KN	KL	KN	KL					
Complete burner code	MB-ZRDLE 412 d1"1/4-Rp1"1/4	-	MB-ZRDLE 407 d3/4"-Rp3/4"	3836356	3836357	3836358	3836359	3836360	3836361	3836362	3836363

**OTHER AVAILABLE VERSIONS**

60 60 Hz version

Ver Versions for continuous ventilation and post-ventilation

**SCOPE OF SUPPLY**

The burner is delivered in its package complete with:

- 1 gas connection flange
- 1 compact gas train with gas filter; the gas filter is built-in for threaded valves (up to 2") and separated for flanged ones (DN65/80/100)
- 1 burner flange with insulation
- 1 bag containing installation fittings
- 1 bag containing technical documentation (instruction manual, technical data, electrical diagram, exploded view and spare parts list)

DIMENSIONS (mm)

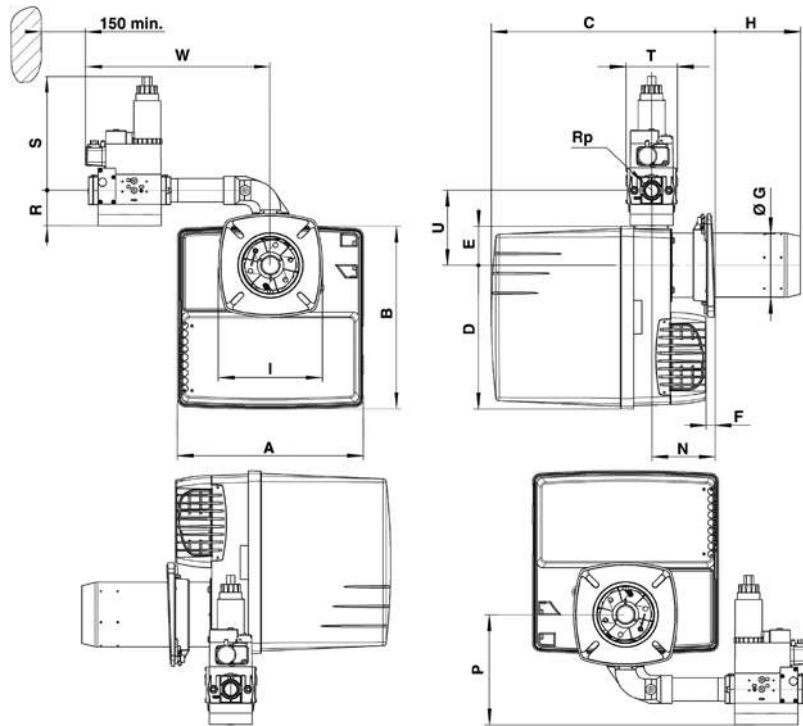

	Gas train model	A	B	C		D	E	F min	ØG	H		I	N min	P	Rp	R	S	T	U	W
				KN	KL					KN	KL									
VG2.120	d3/4"-Rp3/4"	331	325	398...518	398...638	256	69	15	115	30...150	30...270	185	113	179	3/4"	46	210	120	133	330
VG2.160	d3/4"-Rp3/4"	331	325	398...518	398...638	256	69	15	115	30...150	30...270	185	113	179	3/4"	46	210	120	133	330
VG2.205	d3/4"-Rp3/4"	331	325	398...518	398...638	256	69	15	125	30...150	30...270	185	113	179	3/4"	46	210	120	133	330
	d1"1/4-Rp1"1/4	331	325	398...518	398...638	256	69	15	125	30...150	30...270	185	113	188	1"1/4	55	260	145	133	360

Connecting flange

	Øa (mm)	b (mm)	c	d
VG2.120/160	120-135	150-185	M8	45°
VG2.205	130-145	160-185	M8	45°

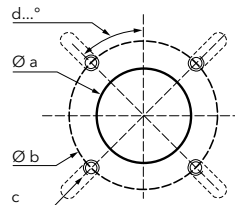

PACKAGING

The burner is delivered in 1 single package containing all components

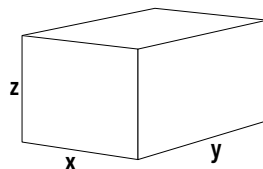

Burner	Dimensions (mm)			Gross weight (kg)
	X	Y	Z	
VG2.120	400	400	760	26
VG2.160	400	400	760	26
VG2.205	400	400	760	26

**VG3.290 D E, VG3.350 D E**

95 ... 350 kW  
2 stages (ErP compliant)

- **Fuels:** natural gas (G20/G25,  $H_u = 8,83...10,35 \text{ kWh/m}^3$ );  
LPG (G31,  $H_u = 25,89 \text{ kWh/m}^3$ )
- **Emissions:** compliant with ErP Directive
- **Protection level:** IP 21



**TECHNICAL DATA**

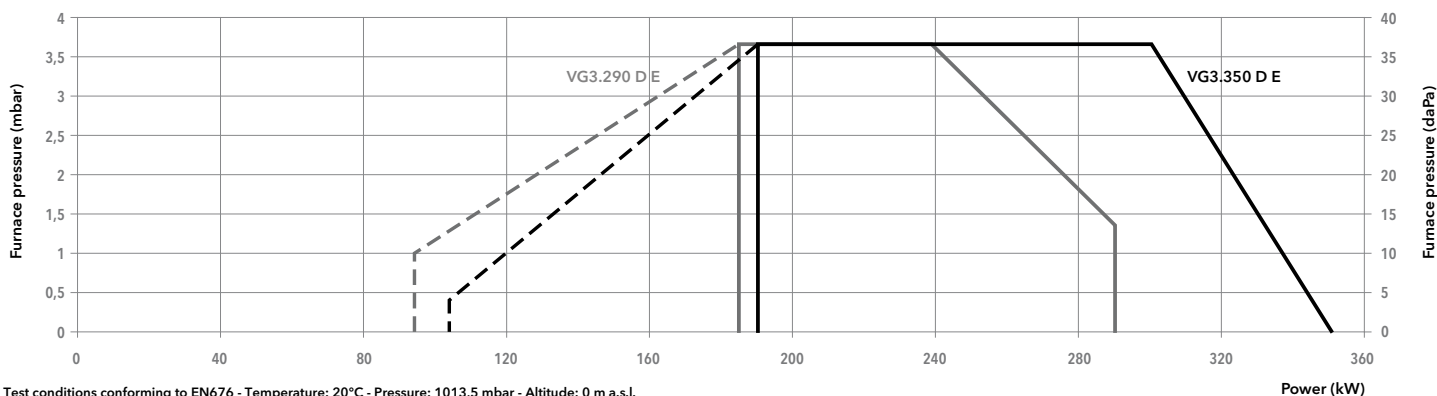

Test conditions conforming to EN676 - Temperature: 20°C - Pressure: 1013,5 mbar - Altitude: 0 m a.s.l.

Model	VG3.290 D E		VG3.350 D E	
Operation range	(95) 185 - 290 kW		(105) 190 - 350 kW	
Gas pressure	20 - 360 mbar		20 - 360 mbar	
Control box / flame detection	TCG2... / ionization		TCG2... / ionization	
Fan motor	230 V - 50 Hz - 250 W		230 V - 50 Hz - 300 W	
Electrical consumption (max/min/stand-by)	465 W / 441 W / 4 W		583 W / 583 W / 4 W	
Acoustic level (LpA)	67 dB(A)		69 dB(A)	
CE certificate	0476 CT 2423		0476 CT 2423	
Head lenght	KN	KL	KN	KL
Complete burner code	MB-ZRDLE 420 d1"1/2-Rp2"	-	3836382	3836383
	MB-ZRDLE 412 d1"1/4-Rp1"1/4	3836378	3836384	3836385
	MB-ZRDLE 407 d3/4"-Rp3/4"	3836380	3836381	3836386

**OTHER AVAILABLE VERSIONS**

- 60 60 Hz version
- TC Version with tightness control
- V<sub>vent</sub> Versions for continuous ventilation and post-ventilation

**SCOPE OF SUPPLY**

- The burner is delivered in its package complete with:
- 1 burner head with flange seal and securing screws
  - 1 compact gas train with gas filter; the gas filter is built-in for threaded valves (up to 2") and separated for flanged ones (DN65/80/100)
  - 1 bag containing installation fittings
  - 1 bag containing technical documentation (instruction manual, technical data, electrical diagram, exploded view and spare parts list)

**DIMENSIONS (mm)**

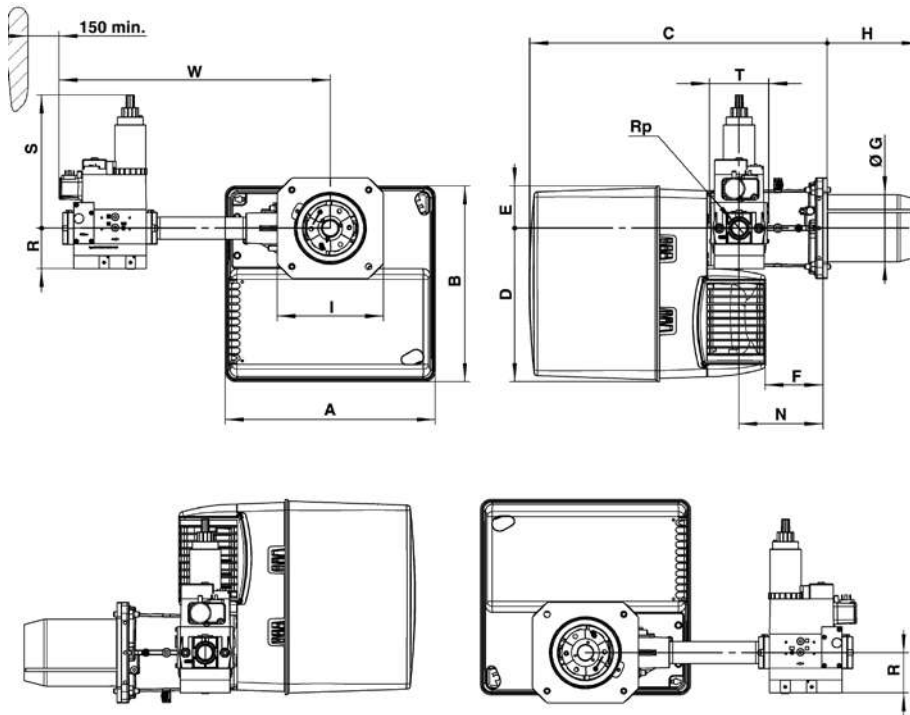

Gas train model	A	B	C	D	E	F	ØG	H		I	N	Rp	R	S	T	W
								KN	KL							
d1"1/2-Rp2"	406	379	576	297	82	120	130	180	320	195x205	170	2"	80	330	100	603
d1"1/4-Rp1"1/4	406	379	576	297	82	120	130	180	320	195x205	170	1"1/4	55	260	145	526
d3/4"-Rp3/4"	406	379	576	297	82	120	130	180	320	195x205	170	3/4"	46	210	120	479

**Connecting flange**

Øa (mm)	b (mm)	c	d
155-190	175-220	M10	45°

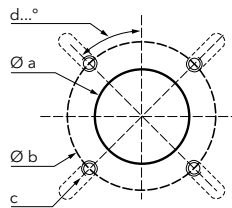

**PACKAGING**

The burner is delivered on a pallet in 3 packages containing:

- burner housing
- combustion head
- gas train and filter

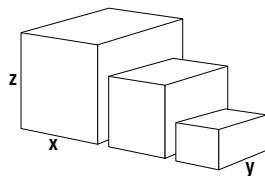

Component		Dimensions (mm)			Gross weight (kg)
		X	Y	Z	
Burner body	VG3.290 D E	440	400	520	21
	VG3.350 D E	440	400	520	21
Combustion head	KN	650	210	260	6
	KL	650	210	260	6
Gas train	d1"1/2-Rp2"	600	400	240	14
	d1"1/4-Rp1"1/4	440	320	240	10
	d3/4"-Rp3/4"	440	320	240	7



**VG3.290 D E, VG3.350 D E**

95 ... 350 kW  
2 stages (ErP compliant)

**PRESSURE LOSS [BURNER HEAD + GAS TRAIN] (mbar)**

**VG3.290 D E**

Burner output (kW)	Natural gas G20 Hi = 10,35 kWh/m <sup>3</sup>		Natural gas G25 Hi = 8,83 kWh/m <sup>3</sup>		LPG G31 Hi = 25,89 kWh/m <sup>3</sup>	
	d3/4"-Rp3/4"	d1"1/4-Rp1"1/4	d3/4"-Rp3/4"	d1"1/4-Rp1"1/4	d3/4"-Rp3/4"	d1"1/4-Rp1"1/4
190	22	10	29	12	13	7
210	24	10	33	13	14	7
230	27	11	38	15	15	7
250	31	12	43	16	16	7
270	36	14	49	18	18	8
290	41	15	56	20	21	9

**Natural gas G20**

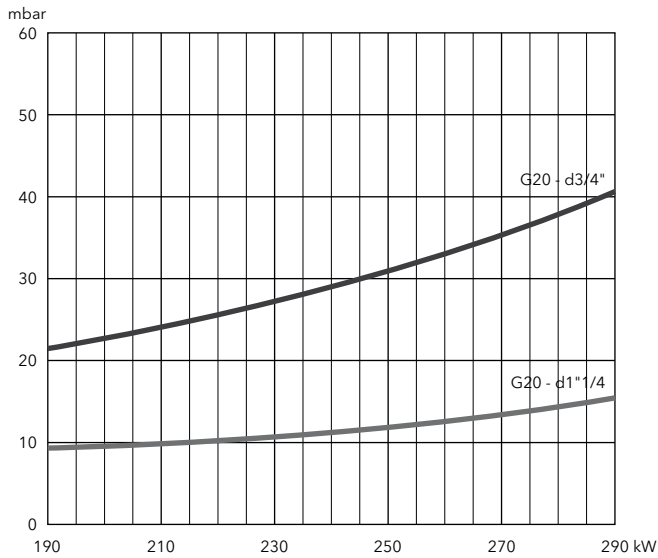

**Natural gas G25**

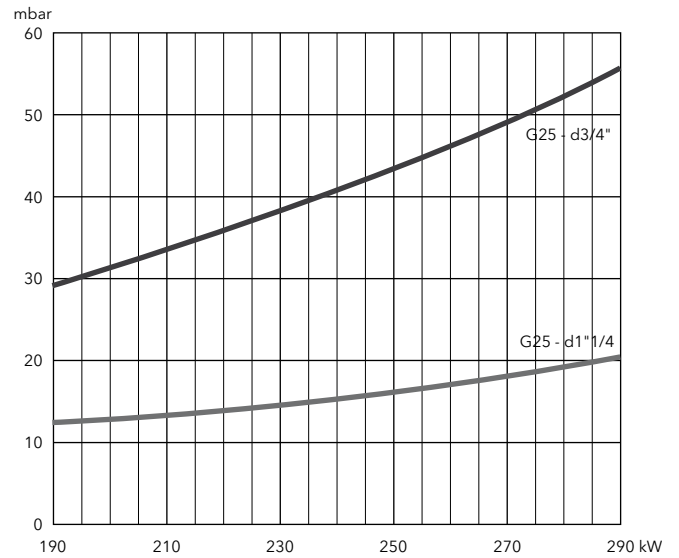

**LPG**

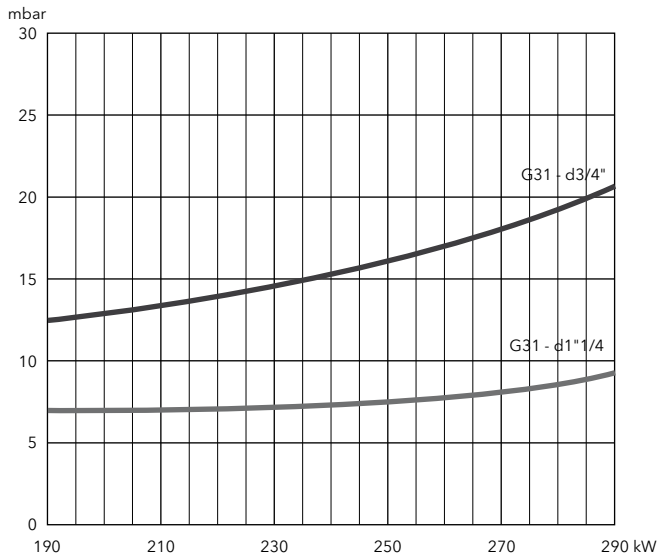



**PRESSURE LOSS [BURNER HEAD + GAS TRAIN] (mbar)**

**VG3.350 D E**

Burner output (kW)	Natural gas G20 Hi = 10,35 kWh/m <sup>3</sup>		Natural gas G25 Hi = 8,83 kWh/m <sup>3</sup>			LPG G31 Hi = 25,89 kWh/m <sup>3</sup>
	d3/4"-Rp3/4"	d1"1/4-Rp1"1/4	d3/4"-Rp3/4"	d1"1/4-Rp1"1/4	d1"1/2-Rp2"	d3/4"-Rp3/4"
190	18	7	27	10	8	10
230	25	9	38	14	9	14
270	33	12	49	18	12	18
310	43	14	62	23	14	23
350	53	18	77	28	19	28

**Natural gas G20**

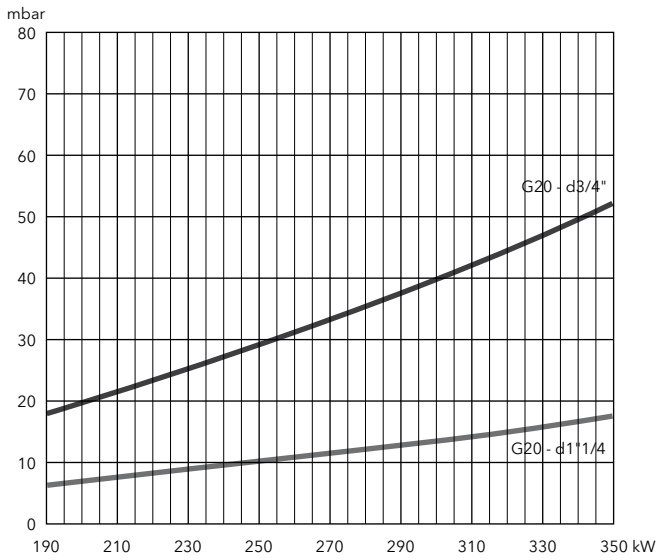

**Natural gas G25**

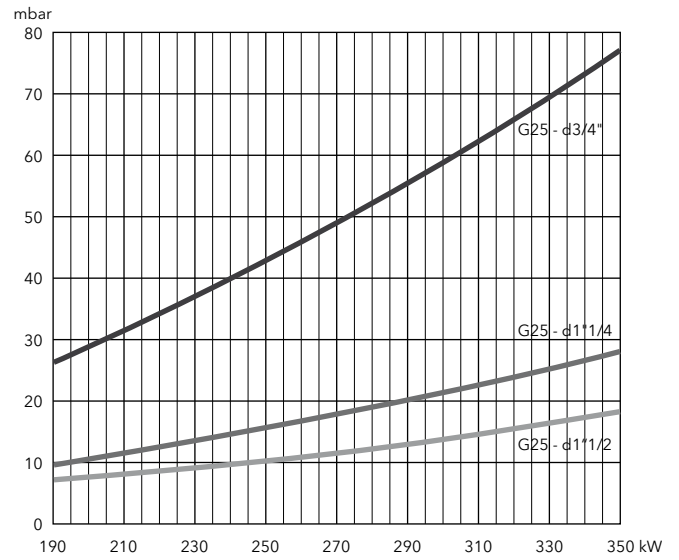

**LPG**

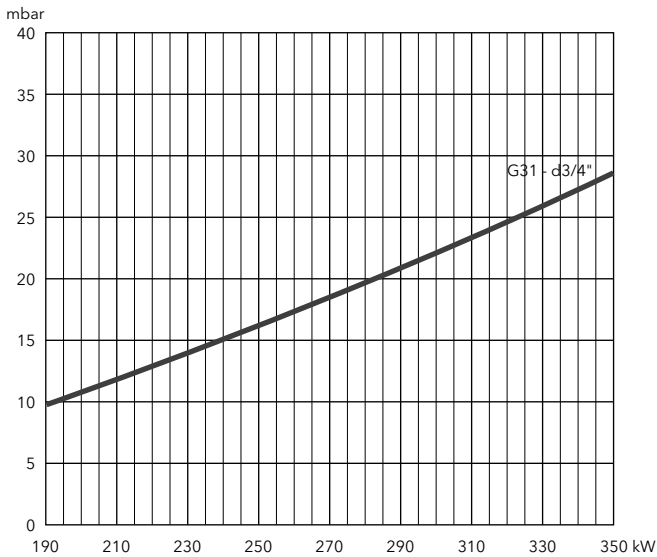

**VG4.440 D E**

110 ... 440 kW  
2 stages (ErP compliant)

- **Fuels:** natural gas (G20/G25,  $H_u = 8,83...10,35 \text{ kWh/m}^3$ );  
LPG (G31,  $H_u = 25,89 \text{ kWh/m}^3$ )
- **Emissions:** compliant with ErP Directive
- **Protection level:** IP 21



**TECHNICAL DATA**

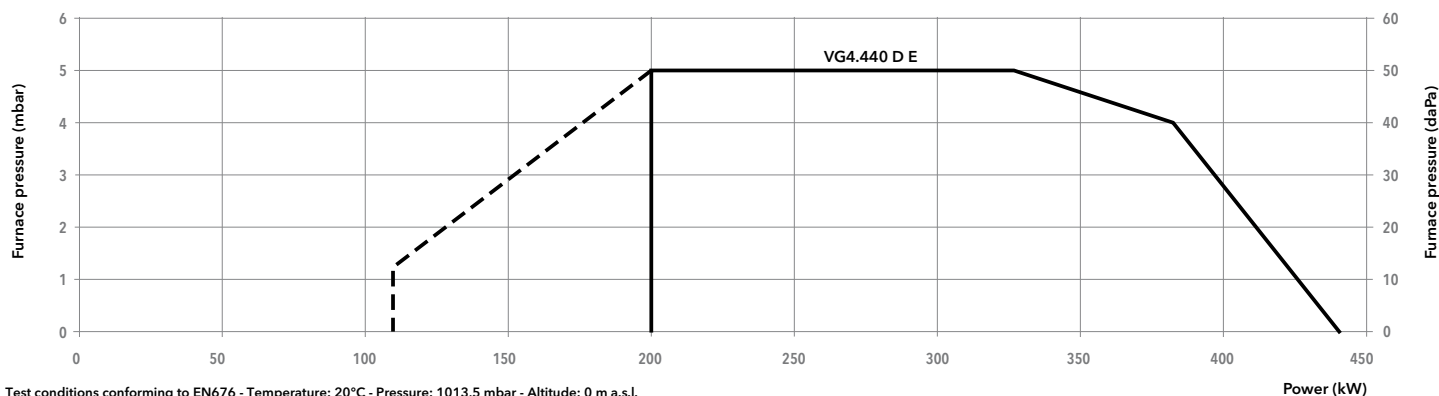

<b>Model</b>	<b>VG4.440 D E</b>		
<b>Operation range</b>	(110) 200 - 440 kW		
<b>Gas pressure</b>	20 - 360 mbar		
<b>Control box / flame detection</b>	TCG2... / ionization		
<b>Fan motor</b>	230 V - 50 Hz - 420 W		
<b>Electrical consumption (max/min/stand-by)</b>	606 W / 569 W / 4 W		
<b>Acoustic level (LpA)</b>	70 dB(A)		
<b>CE certificate</b>	0476 CT 2423		
<b>Head lenght</b>	KN		KL
<b>Complete burner code</b>	MB-ZRDLE 420 d1"1/2-Rp2"	<b>3836398</b>	<b>3836399</b>
	MB-ZRDLE 412 d1"1/4-Rp1"1/4	<b>3836400</b>	<b>3836401</b>
	MB-ZRDLE 407 d3/4"-Rp3/4"	<b>3836402</b>	<b>3836403</b>

**OTHER AVAILABLE VERSIONS**

- 60 60 Hz version
- TC Version with tightness control
- V<sub>vent</sub> Versions for continuous ventilation and post-ventilation

**SCOPE OF SUPPLY**

- The burner is delivered in its package complete with:
- 1 burner head with flange seal and securing screws
  - 1 compact gas train with gas filter; the gas filter is built-in for threaded valves (up to 2") and separated for flanged ones (DN65/80/100)
  - 1 bag containing installation fittings
  - 1 bag containing technical documentation (instruction manual, technical data, electrical diagram, exploded view and spare parts list)



**DIMENSIONS (mm)**

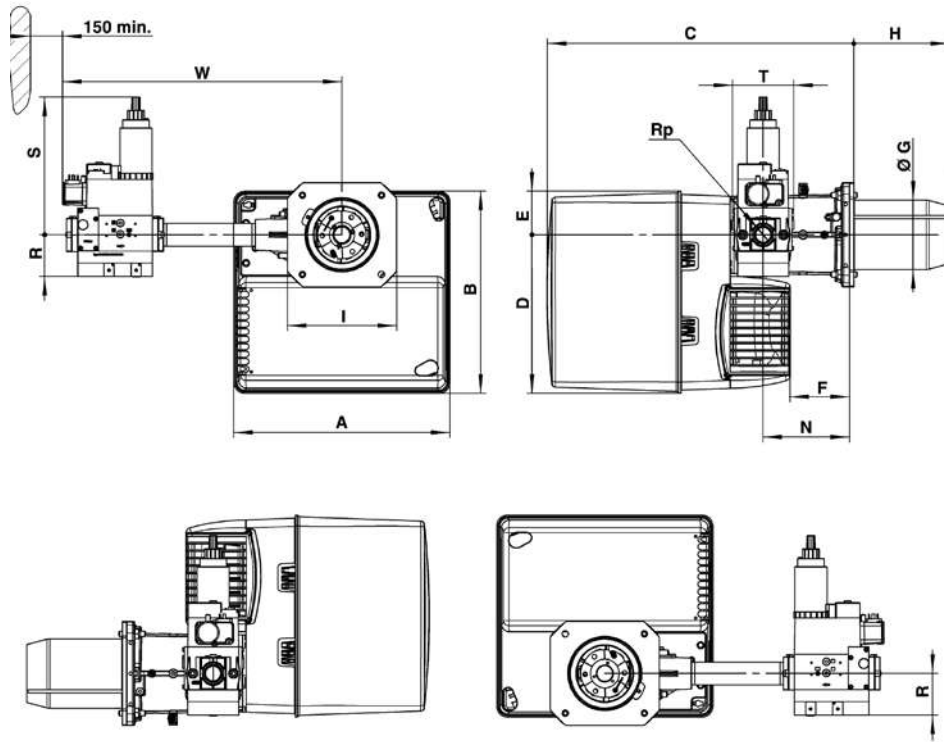

Gas train model	A	B	C	D	E	F	ØG	H		I	N	Rp	R	S	T	W
								KN	KL							
d1"1/2-Rp2"	465	475	640	377	97	149	157	212	352	245	195	2"	80	330	100	613
d1"1/4-Rp1"1/4	465	475	640	377	97	149	157	212	352	245	195	1"1/4	55	260	145	536
d3/4"-Rp3/4"	465	475	640	377	97	149	157	212	352	245	195	3/4"	46	210	120	489

**Connecting flange**

Øa (mm)	b (mm)	c	d
190-240	200-270	M10	45°

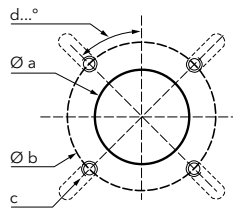

**PACKAGING**

The burner is delivered on a pallet in 3 packages containing:

- burner housing
- combustion head
- gas train and filter

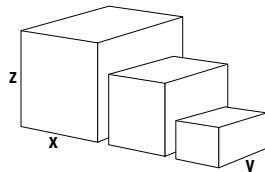

Component	Component	Dimensions (mm)			Gross weight (kg)
		X	Y	Z	
Burner body	VG4.440 D E	490	490	590	28,7
	KN	750	260	295	8,9
Combustion head	KL	895	260	295	10,1
	d1"1/2-Rp2"	600	400	240	14
Gas train	d1"1/4-Rp1"1/4	440	320	240	10
	d3/4"-Rp3/4"	440	320	240	7

**VG4.440 D E**

110 ... 440 kW  
2 stages (ErP compliant)

**PRESSURE LOSS [BURNER HEAD + GAS TRAIN] (mbar)**

**VG4.440 D E**

Burner output (kW)	Natural gas G20 Hi = 10,35 kWh/m <sup>3</sup>			Natural gas G25 Hi = 8,83 kWh/m <sup>3</sup>		
	d3/4"-Rp3/4"	d1"1/4-Rp1"1/4	d1"1/2-Rp2"	d3/4"-Rp3/4"	d1"1/4-Rp1"1/4	d1"1/2-Rp2"
240	27	9	6	39	13	9
280	35	12	6	50	16	10
320	43	14	7	62	20	11
360	53	17	9	76	24	14
400	64	20	11	91	29	17
440	76	24	13	107	34	19

**Natural gas G20**

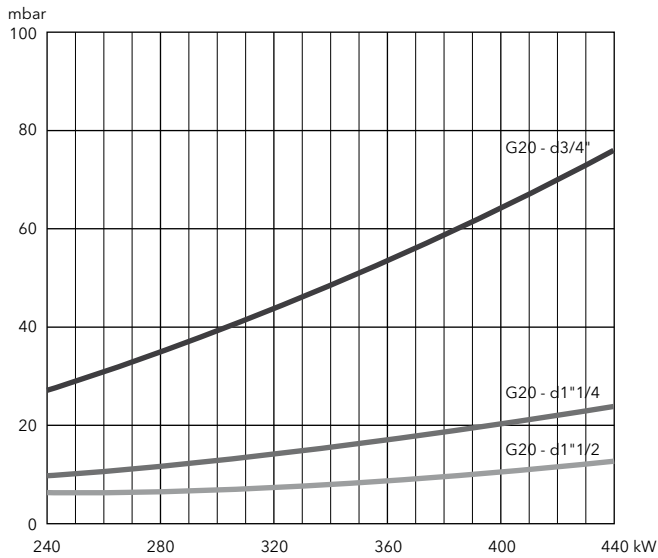

**Natural gas G25**

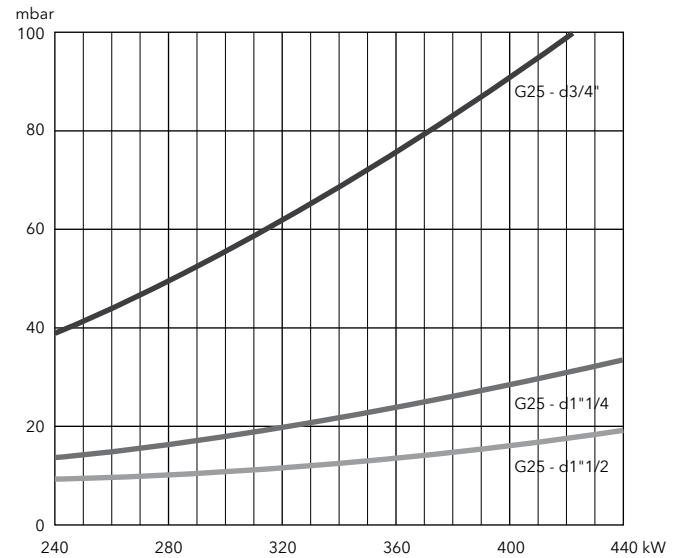



**PRESSURE LOSS [BURNER HEAD + GAS TRAIN] (mbar)**

Burner output (kW)	LPG G31 Hi = 25,89 kWh/m <sup>3</sup>	
	d3/4"-Rp3/4"	d1"1/4-Rp1"1/4
240	16	8
280	20	9
320	24	10
360	29	12
400	35	15
440	42	18

**LPG**

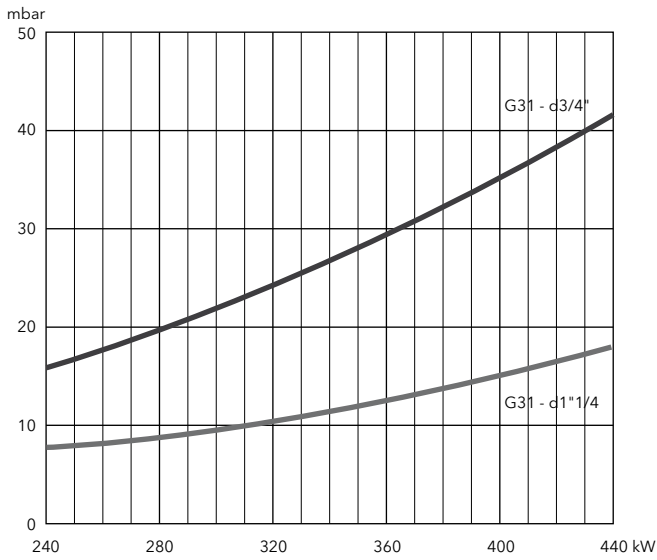



**VG2.120 DP E, VG2.160 DP E, VG2.205 DP E**

40 ... 205 kW

2 stage progressive/modulating pneumatic (ErP compliant)

- **Fuels:** natural gas (G20/G25,  $H_u = 8,83...10,35 \text{ kWh/m}^3$ ); LPG (G31,  $H_u = 25,89 \text{ kWh/m}^3$ )
- **Emissions:** compliant with ErP Directive
- **Operation:** two stage progressive or modulating with the installation of a power regulator and dedicated probes (see pag. 180)
- **Protection level:** IP 21

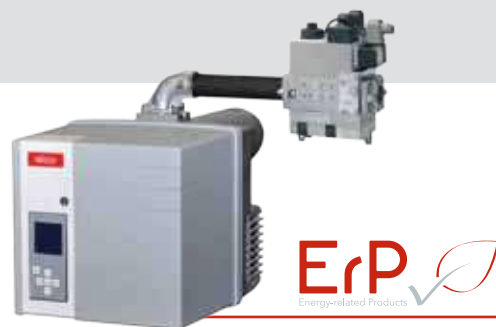

**TECHNICAL DATA**

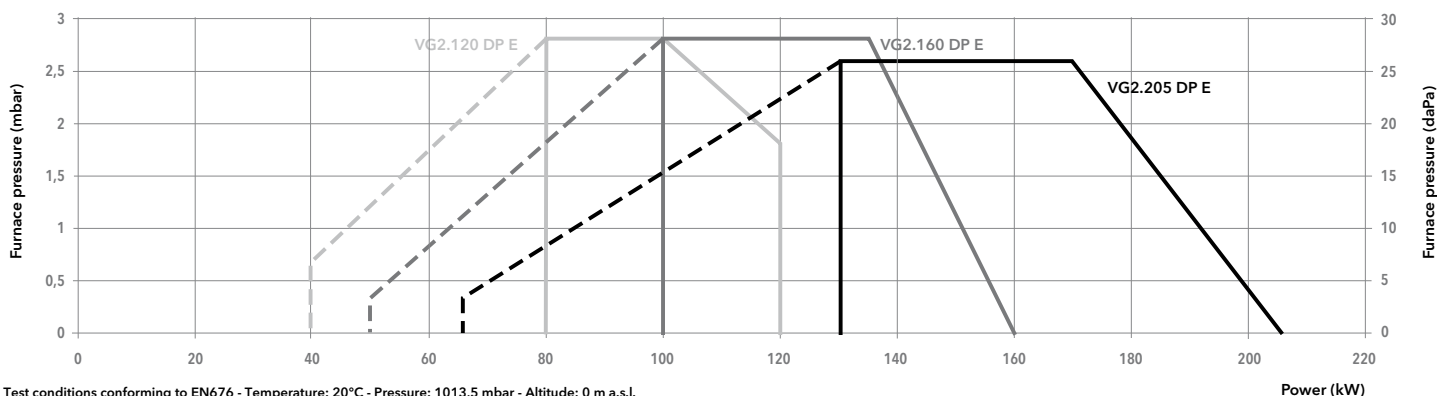

Test conditions conforming to EN676 - Temperature: 20°C - Pressure: 1013,5 mbar - Altitude: 0 m a.s.l.

Model	VG2.120 DP E		VG2.160 DP E		VG2.205 DP E	
Operation range	(40) 80 - 120 kW		(50) 100 - 160 kW		(65) 130 - 205 kW	
Gas pressure	20 - 100 mbar for d332 gas train; 20 - 300 mbar for d333 gas train		20 - 100 mbar for d345 gas train; 20 - 300 mbar for d347 gas train		20 - 40 mbar for d348 gas train; 40 - 100 for d346, 100 - 300 for d345	
Control box / flame detection	TCG5... / ionization		TCG5... / ionization		TCG5... / ionization	
Fan motor	230 V - 50 Hz - 100 W		230 V - 50 Hz - 100 W		230 V - 50 Hz - 130 W	
Electrical consumption (max/min/stand-by)	239 W / 358 W / 4 W		285 W / 293 W / 4 W		302 W / 267 W / 4 W	
Acoustic level (LpA)	62 dB(A)		64 dB(A)		65 dB(A)	
CE certificate	0476 CT 2423		0476 CT 2423		0476 CT 2423	
Head lenght	KN	KL	KN	KL	KN	KL
Complete burner code	MB-VEF 407 d332-3/4"-Rp3/4"	<b>3836364</b>	<b>3836365</b>	-	-	-
	MB-VEF 407 d333-3/4"-Rp3/4"	<b>3836366</b>	<b>3836367</b>	-	-	-
	MB-VEF 407 d345-3/4"-Rp3/4"	-	-	<b>3836368</b>	<b>3836369</b>	<b>3836374</b>
	MB-VEF 407 d346-3/4"-Rp3/4"	-	-	-	-	<b>3836376</b>
	MB-VEF 407 d347-3/4"-Rp3/4"	-	-	<b>3836370</b>	<b>3836371</b>	-
	MB-VEF 412 d348-1"1/4-Rp1"1/4"	-	-	-	-	<b>3836372</b>

**OTHER AVAILABLE VERSIONS**

60 Hz version

Versions for continuous ventilation and post-ventilation

**SCOPE OF SUPPLY**

The burner is delivered in its package complete with:

- 1 gas connection flange
- 1 compact gas train with gas filter; the gas filter is built-in for threaded valves (up to 2") and separated for flanged ones (DN65/80/100)
- 1 burner flange with insulation
- 1 bag containing installation fittings
- 1 bag containing technical documentation (instruction manual, technical data, electrical diagram, exploded view and spare parts list)



**DIMENSIONS (mm)**

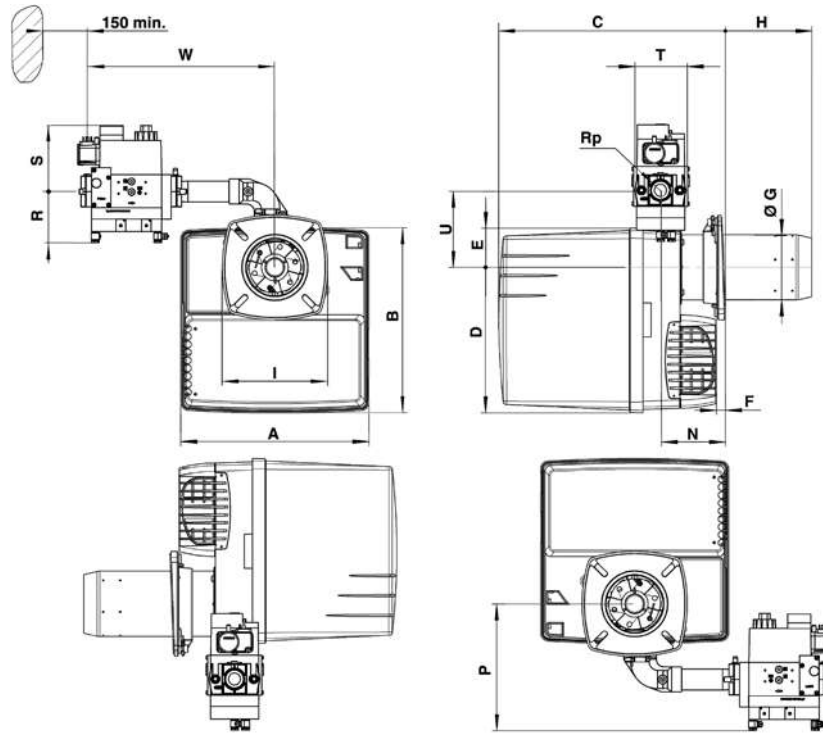

	Gas train model	A	B	C		D	E	F min	ØG	H		I	N min	P	Rp	R	S	T	U	W
				KN	KL					KN	KL									
VG2.120	d3/4"-Rp3/4"	331	325	398...518	398...638	256	69	15	115	30...150	30...270	185	113	179	3/4"	70	160	120	133	345
VG2.160	d3/4"-Rp3/4"	331	325	398...518	398...638	256	69	15	115	30...150	30...270	185	113	179	3/4"	70	160	120	133	345
VG2.205	d3/4"-Rp3/4"	331	325	398...518	398...638	256	69	15	125	30...150	30...270	185	113	179	3/4"	70	160	120	133	345
	d1"1/4-Rp1"1/4	331	325	398...518	398...638	256	69	15	125	30...150	30...270	185	113	188	1"1/4	80	175	145	133	380

**Connecting flange**

	Øa (mm)	b (mm)	c	d
VG2.120/160	120-135	150-185	M8	45°
VG2.205	130-145	160-185	M8	45°

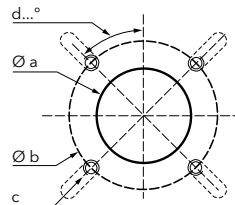

**PACKAGING**

The burner is delivered in 1 single package containing all components

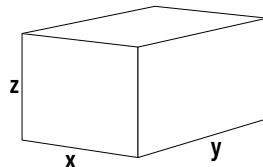

Dimensions (mm)			Gross weight (kg)
X	Y	Z	
400	400	760	26

**VG3.290 DP E, VG3.350 DP E**

95 ... 350 kW  
2 stages progressive/modulating pneumatic (ErP compliant)

- **Fuels:** natural gas (G20/G25,  $H_u = 8,83...10,35 \text{ kWh/m}^3$ ); LPG (G31,  $H_u = 25,89 \text{ kWh/m}^3$ )
- **Emissions:** compliant with ErP Directive
- **Operation:** two stage progressive or modulating with the installation of a power regulator and dedicated probes (see pag. 180)
- **Protection level:** IP 21



**TECHNICAL DATA**

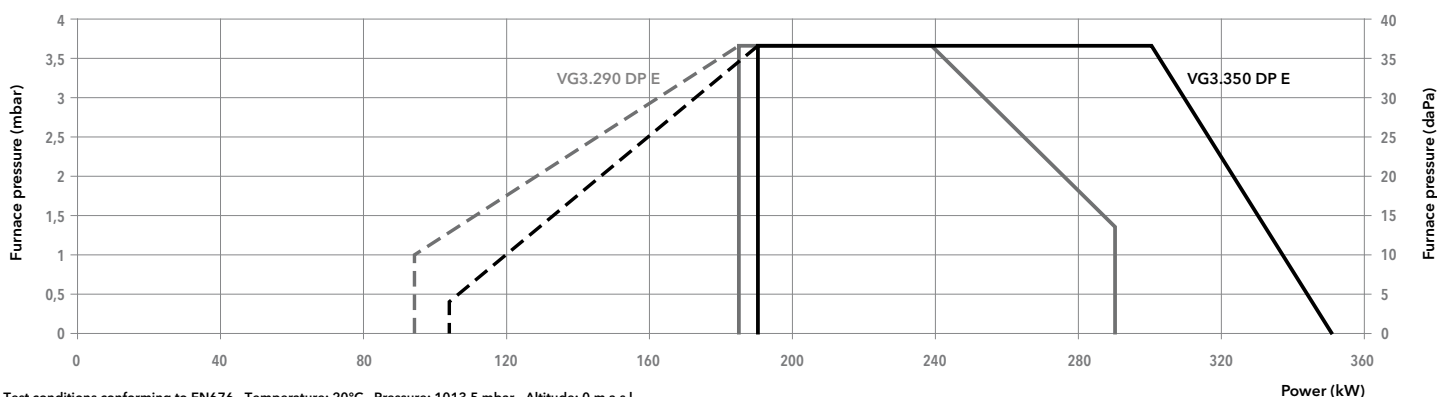

Test conditions conforming to EN676 - Temperature: 20°C - Pressure: 1013,5 mbar - Altitude: 0 m a.s.l.

	VG3.290 DP E		VG3.350 DP E	
<b>Operation range</b>	(95) 185 - 290 kW		(105) 190 - 350 kW	
<b>Gas pressure</b>	20 - 360 mbar		20 - 360 mbar	
<b>Control box / flame detection</b>	TCG5... / ionization		TCG5... / ionization	
<b>Fan motor</b>	230 V - 50 Hz - 250 W		230 V - 50 Hz - 300 W	
<b>Electrical consumption (max/min/stand-by)</b>	465 W / 441 W / 4 W		583 W / 583 W / 4 W	
<b>Acoustic level (LpA)</b>	67 dB(A)		69 dB(A)	
<b>CE certificate</b>	0476 CT 2423		0476 CT 2423	
<b>Head lenght</b>	KN	KL	KN	KL
<b>Complete burner code</b>	MB-VEF 420 d1"1/2-Rp2"	-	<b>3836414</b>	<b>3836415</b>
	MB-VEF 412 d1"1/4-Rp1"1/4	<b>3836410</b>	<b>3836416</b>	<b>3836417</b>
	MB-VEF 407 d3/4"-Rp1"	<b>3836412</b>	<b>3836418</b>	<b>3836419</b>

**OTHER AVAILABLE VERSIONS**

- 60 60 Hz version
- TC Version with tightness control
- V<sub>vent</sub> Versions for continuous ventilation and post-ventilation

**SCOPE OF SUPPLY**

- The burner is delivered in its package complete with:
- 1 burner head with flange seal and securing screws
  - 1 compact gas train with gas filter; the gas filter is built-in for threaded valves (up to 2") and separated for flanged ones (DN65/80/100)
  - 1 bag containing installation fittings
  - 1 bag containing technical documentation (instruction manual, technical data, electrical diagram, exploded view and spare parts list)



**DIMENSIONS (mm)**

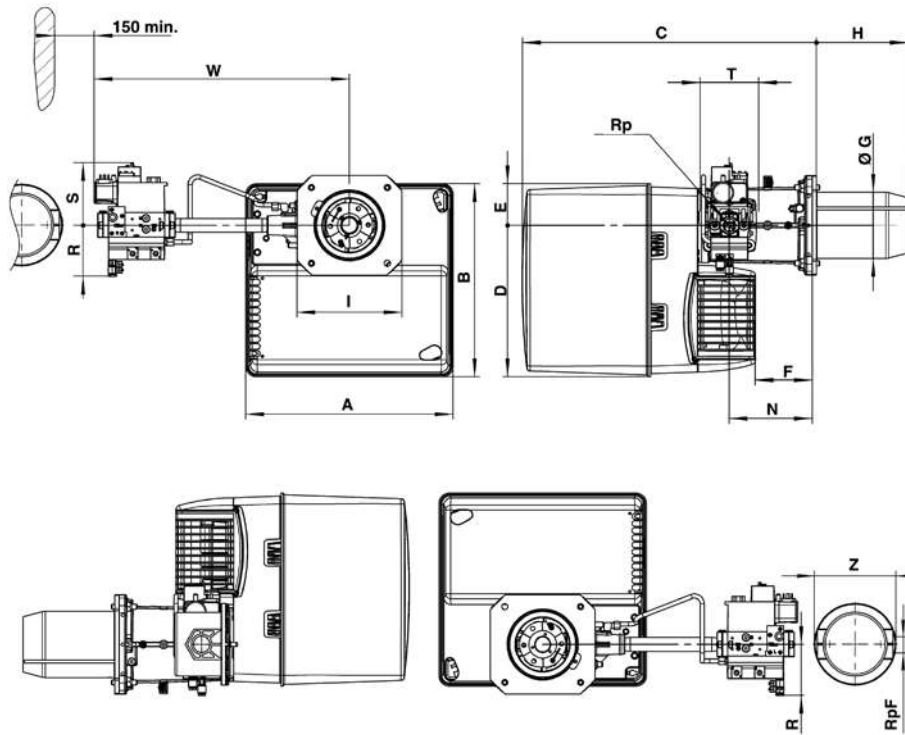

Gas train model	A	B	C	D	E	F	ØG	H		I	N	Rp	R	S	T	W	RpF	Z
								KN	KL									
d1"1/2-Rp2"	406	379	576	297	82	120	130	180	320	195x205	170	2"	100	185	100	603	-	-
d1"1/4-Rp1"1/4	406	379	576	297	82	120	130	180	320	195x205	170	1"1/4	80	175	145	526	-	-
d3/4"-Rp1"	406	379	576	297	82	120	130	180	320	195x205	170	1"	70	160	120	479	1"	160

**Connecting flange**

Øa (mm)	b (mm)	c	d
155-190	175-220	M10	45°

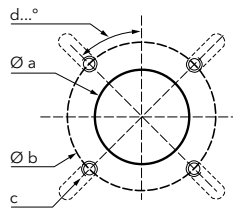

**PACKAGING**

The burner is delivered on a pallet in 3 packages containing:

- burner housing
- combustion head
- gas train and filter

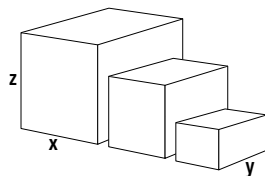

Component		Dimensions (mm)			Gross weight (kg)
		X	Y	Z	
Body	VG3.290 DP E	440	400	520	21
	VG3.350 DP E	440	400	520	21
Combustion head	KN	650	210	260	6
	KL	780	210	260	7
Gas train	d1"1/2-Rp2"	670	550	380	12
	d1"1/4-Rp1"1/4	600	400	240	11
	d3/4"-Rp1"	600	400	240	7

**VG3.290 DP E, VG3.350 DP E**

95 ... 350 kW

2 stages progressive/modulating pneumatic (ErP compliant)

**PRESSURE LOSS [BURNER HEAD + GAS TRAIN] (mbar)**

**VG3.290 DP E**

Burner output (kW)	Natural gas G20 Hi = 10,35 kWh/m <sup>3</sup>		Natural gas G25 Hi = 8,83 kWh/m <sup>3</sup>		LPG G31 Hi = 25,89 kWh/m <sup>3</sup>	
	d3/4"-Rp1"	d1"1/4-Rp1"1/4	d3/4"-Rp1"	d1"1/4-Rp1"1/4	d3/4"-Rp1"	d1"1/4-Rp1"1/4
190	17	9	22	11	11	7
210	18	9	24	12	12	7
230	20	9	27	12	12	7
250	22	10	31	13	13	8
270	25	11	35	15	14	8
290	29	13	40	16	16	9

**Natural gas G20**

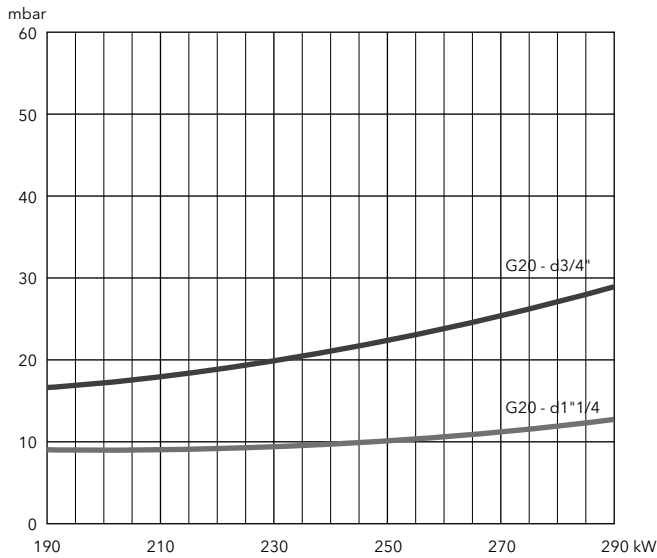

**Natural gas G25**

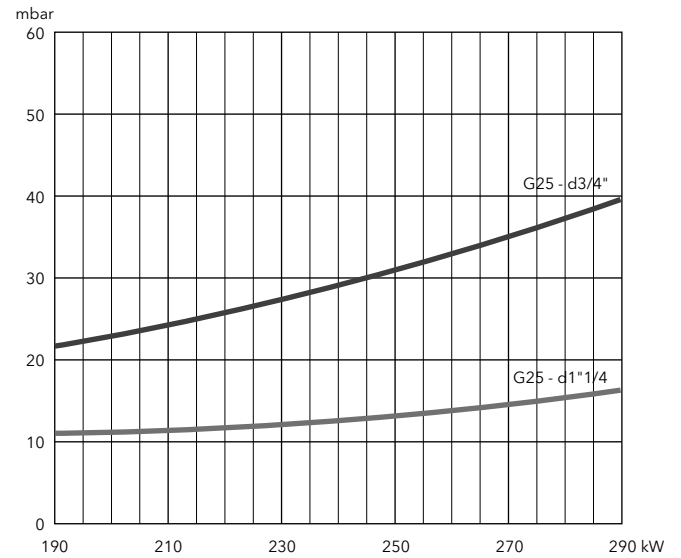

**LPG**

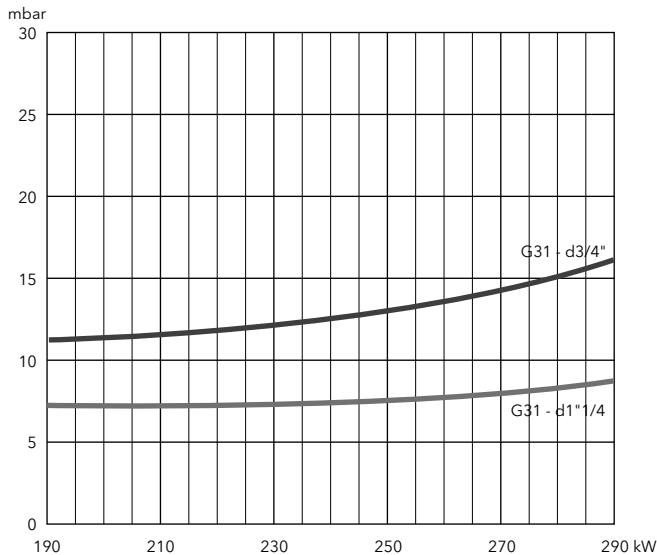



**PRESSURE LOSS [BURNER HEAD + GAS TRAIN] (mbar)**

**VG3.350 DP E**

Burner output (kW)	Natural gas G20 Hi = 10,35 kWh/m <sup>3</sup>			Natural gas G25 Hi = 8,83 kWh/m <sup>3</sup>			LPG G31
	d3/4"-Rp1"	d1"1/4-Rp1"1/4	d1"1/2-Rp2"	d3/4"-Rp1"	d1"1/4-Rp1"1/4	d1"1/2-Rp2"	d3/4"-Rp1"
190	13	6	6	19	8	8	8
230	17	7	7	26	11	10	12
270	23	9	8	35	15	13	15
310	29	11	10	44	18	16	18
350	36	14	12	54	22	19	22

**Natural gas G20**

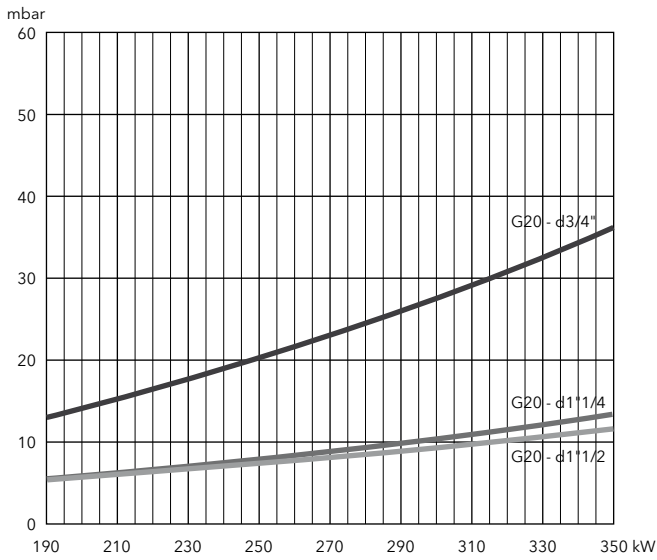

**Natural gas G25**

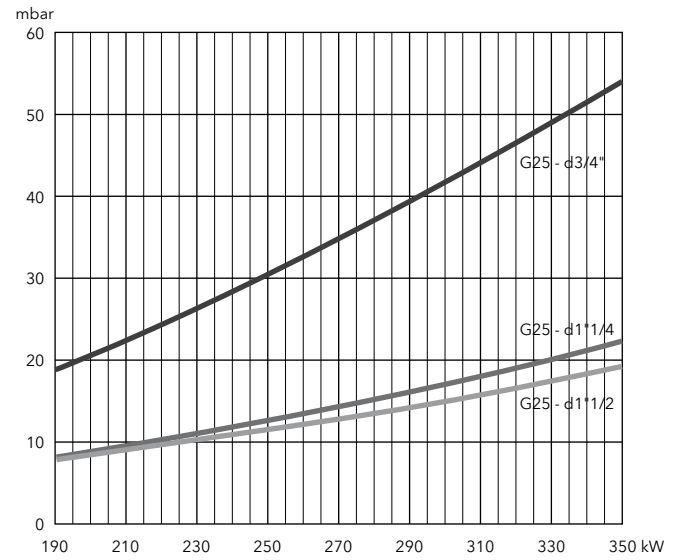

**LPG**

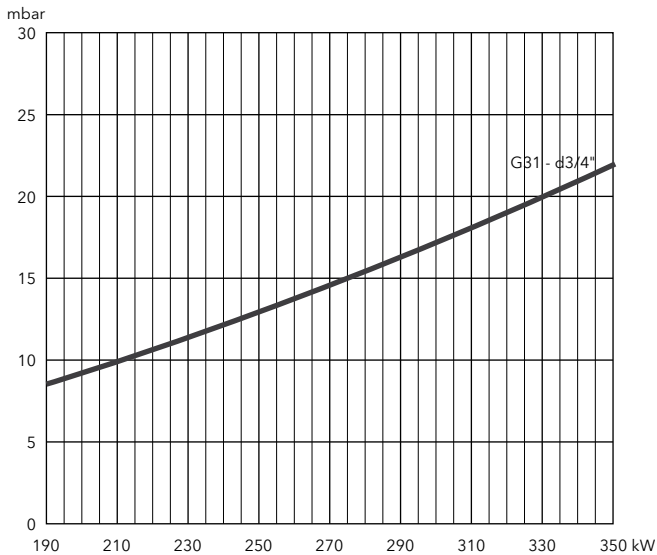



**VG4.440 DP E****110 ... 440 kW****2 stage progressive/modulating pneumatic (ErP compliant)**

- **Fuels:** natural gas (G20/G25,  $H_u = 8,83...10,35 \text{ kWh/m}^3$ );  
LPG (G31,  $H_u = 25,89 \text{ kWh/m}^3$ )
- **Emissions:** compliant with ErP Directive
- **Operation:** two stage progressive or modulating with the installation of a power regulator and dedicated probes (see pag. 180)
- **Protection level:** IP 21

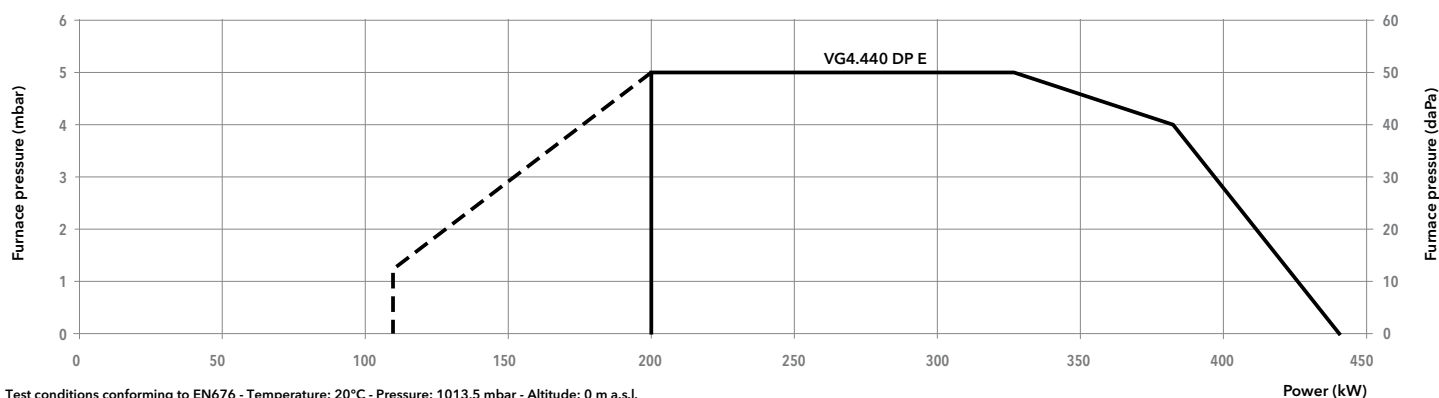
**TECHNICAL DATA**

Model		VG4.440 DP E	
Operation range		(110) 200 - 440 kW	
Gas pressure		20 - 360 mbar	
Control box / flame detection		TCG5.../ionization	
Fan motor		230 V - 50 Hz - 420 W	
Electrical consumption (max/min/stand-by)		606 W / 569 W / 4 W	
Acoustic level (LpA)		70 dB(A)	
CE certificate		0476 CT 2423	
Head lenght		KN	KL
Complete burner code	MB-VEF 420 d1"1/2-Rp2"	3836430	3836431
	MB-VEF 412 d1"1/4-Rp1"1/4	3836432	3836433
	MB-VEF 407 d3/4"-Rp1"	3836434	3836435

**OTHER AVAILABLE VERSIONS**

- 60 60 Hz version
- TC Version with tightness control
- V<sub>vent</sub> Versions for continuous ventilation and post-ventilation

**SCOPE OF SUPPLY**

The burner is delivered in its package complete with:

- 1 burner head with flange seal and securing screws
- 1 compact gas train with gas filter; the gas filter is built-in for threaded valves (up to 2") and separated for flanged ones (DN65/80/100)
- 1 bag containing installation fittings
- 1 bag containing technical documentation (instruction manual, technical data, electrical diagram, exploded view and spare parts list)



**DIMENSIONS (mm)**

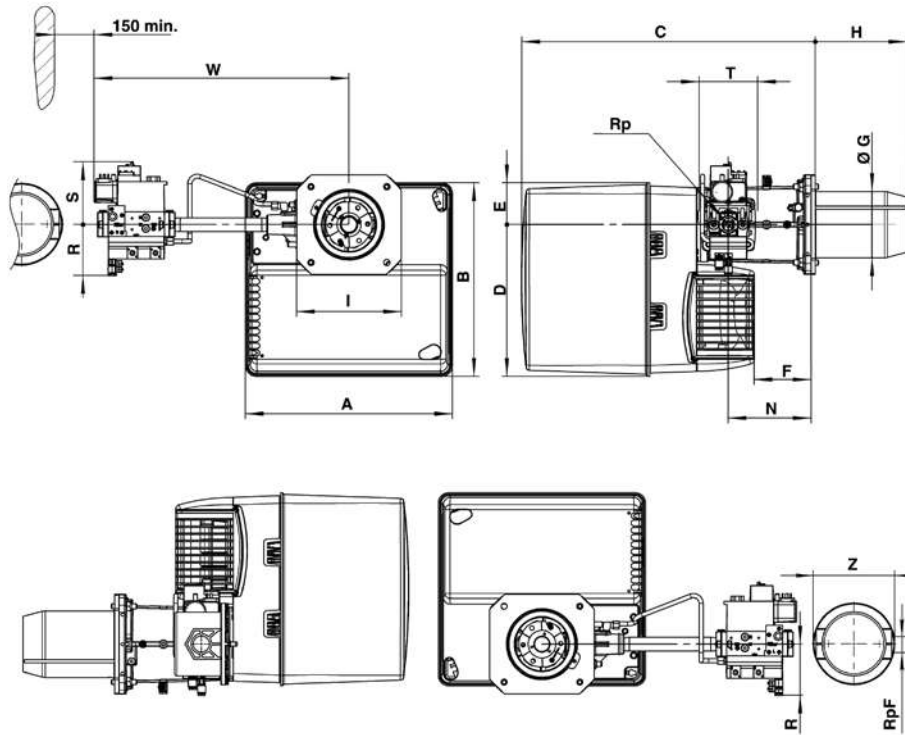

Gas train model	A	B	C	D	E	F	ØG	H		I	N	Rp	R	S	T	W	RpF	Z
								KN	KL									
d1"1/2-Rp2"	465	475	640	377	97	149	157	212	352	245	195	2"	100	185	100	613	-	-
d1"1/4-Rp1"1/4	465	475	640	377	97	149	157	212	352	245	195	1"1/4	80	175	145	536	-	-
d3/4"-Rp1"	465	475	640	377	97	149	157	212	352	245	195	1"	70	160	120	489	1"	160

**Connecting flange**

Øa (mm)	b (mm)	c	d
190-240	200-270	M10	45°

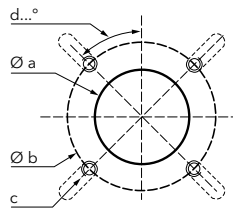

**PACKAGING**

The burner is delivered on a pallet in 3 packages containing:

- burner housing
- combustion head
- gas train and filter

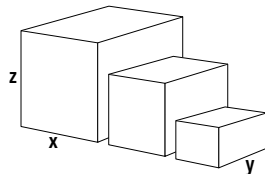

Component		Dimensions (mm)			Gross weight (kg)
		X	Y	Z	
Burner body	VG4.440 DP E	490	490	590	28,6
	KN	750	260	295	8,9
Combustion head	KL	895	260	295	10,1
	d1"1/2-Rp2"	670	550	380	12
Gas train	d1"1/4-Rp1"1/4	600	400	240	11
	d3/4"-Rp1"	600	400	240	7

**VG4.440 DP E**

110 ... 440 kW

2 stage progressive/modulating pneumatic (ErP compliant)

**PRESSURE LOSS [BURNER HEAD + GAS TRAIN] (mbar)**

**VG4.440 DP E**

Burner output (kW)	Natural gas G20 Hi = 10,35 kWh/m <sup>3</sup>			Natural gas G25 Hi = 8,83 kWh/m <sup>3</sup>		
	d3/4"-Rp1"	d1"1/4-Rp1"1/4	d1"1/2-Rp2"	d3/4"-Rp1"	d1"1/4-Rp1"1/4	d1"1/2-Rp2"
240	19	8	7	27	11	10
280	24	9	8	35	13	11
320	30	11	9	42	15	12
360	37	13	11	51	18	15
400	44	15	13	64	22	17
440	51	18	15	78	25	20

**Natural gas G20**

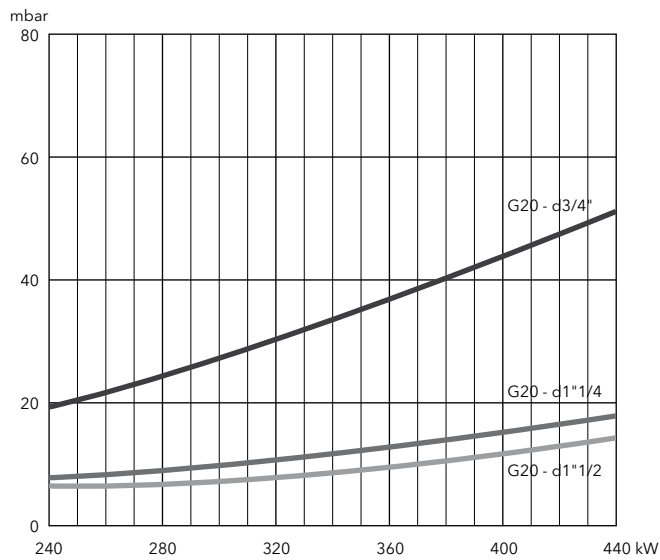

**Natural gas G25**

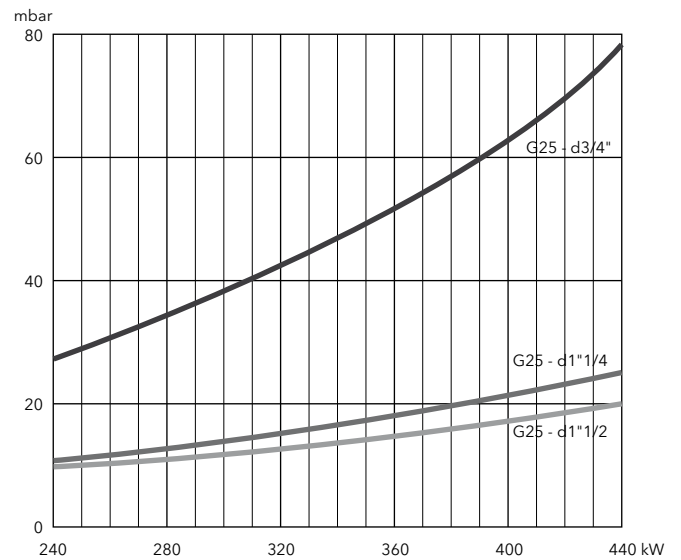



**PRESSURE LOSS [BURNER HEAD + GAS TRAIN] (mbar)**

Burner output (kW)	LPG G31 Hi = 25,89 kWh/m <sup>3</sup>	
	d3/4"-Rp1"	d1"1/4-Rp1"1/4
240	13	8
280	16	9
320	18	10
360	22	11
400	26	13
440	32	16

**LPG**

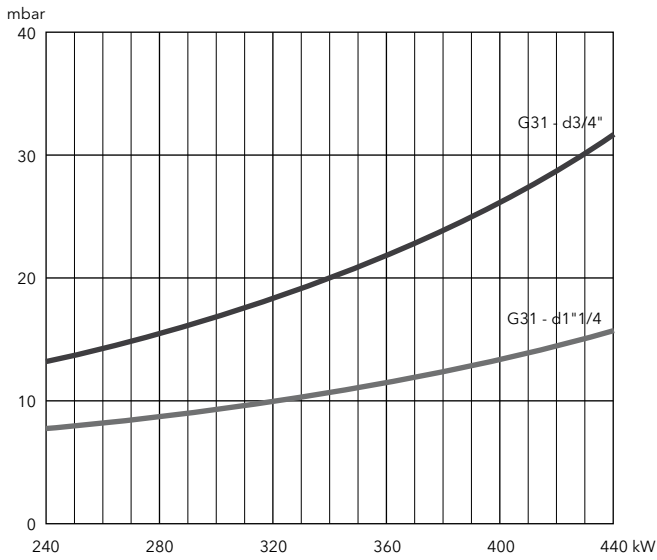

**VG4.610 DP****130 ... 610 kW****2 stage progressive/modulating pneumatic (Low NOx class 3)**

- **Fuels:** natural gas (G20/G25,  $H_u = 8,83...10,35 \text{ kWh/m}^3$ );  
LPG (G31,  $H_u = 25,89 \text{ kWh/m}^3$ )
- **Emissions:** Low NOx class 3 ( $\leq 80 \text{ mg/kWh}$ ) according to EN676
- **Operation:** two stage progressive or modulating with the installation of a power regulator and dedicated probes (see pag. 180)
- **Protection level:** IP 41

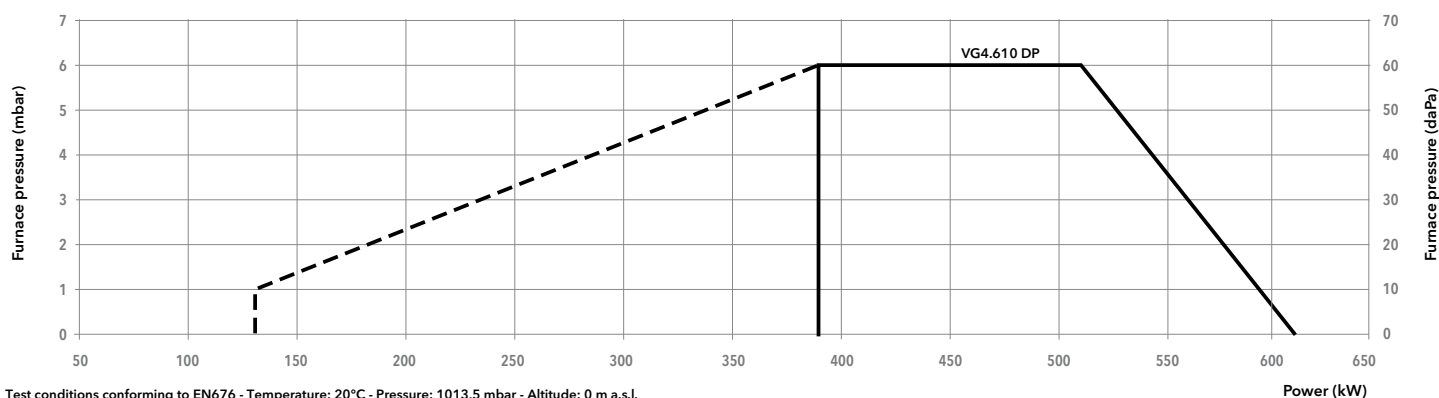
**TECHNICAL DATA**

Model		VG4.610 DP	
Operation range		(130) 390 - 610 kW	
Gas pressure		20 - 300 mbar	
Control box / flame detection		TCG5.../ionization	
Fan motor		230 V - 50 Hz - 750 W	
Electrical consumption		68 + 720 W	
Acoustic level (LpA)		71 dB(A)	
CE certificate		1312 CL 5412	
Head lenght		KN	KL
Complete burner code	MB-VEF 420 d1"1/2-Rp2"	3833415	3833416
	MB-VEF 412 d1"1/4-Rp1"1/4	3833417	3833418
	MB-VEF 407 d3/4"-Rp1"	3833419	3833420

**OTHER AVAILABLE VERSIONS**

- 60 60 Hz version
- TC Version with tightness control
- V<sub>vent</sub> Versions for continuous ventilation and post-ventilation

**SCOPE OF SUPPLY**

The burner is delivered in its package complete with:

- 1 burner head with flange seal and securing screws
- 1 compact gas train with gas filter; the gas filter is built-in for threaded valves (up to 2") and separated for flanged ones (DN65/80/100)
- 1 bag containing installation fittings
- 1 bag containing technical documentation (instruction manual, technical data, electrical diagram, exploded view and spare parts list)

DIMENSIONS (mm)

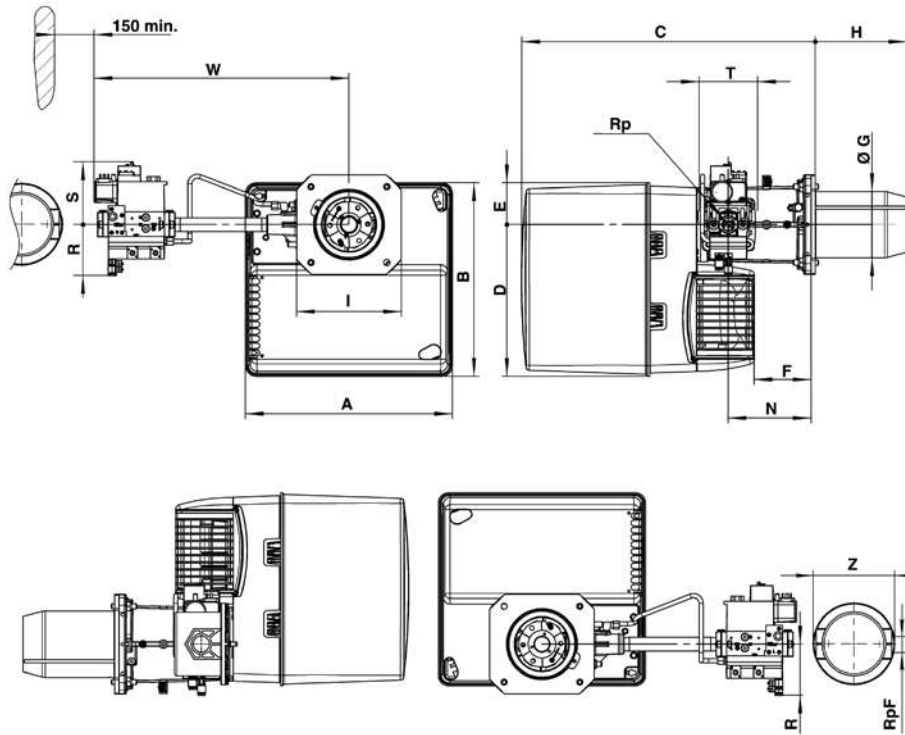

Gas train model	A	B	C	D	E	F	ØG	H		I	N	Rp	R	S	T	W	RpF	Z
								KN	KL									
d1"1/2-Rp2"	465	475	640	377	97	149	150	220	360	245	195	2"	100	185	100	613	-	-
d1"1/4-Rp1"1/4	465	475	640	377	97	149	150	220	360	245	195	1"1/4	80	175	145	536	-	-
d3/4"-Rp1"	465	475	640	377	97	149	150	220	360	245	195	1"	70	160	120	489	1"	160

Connecting flange

Øa (mm)	b (mm)	c	d
180-240	200-270	M10	45°

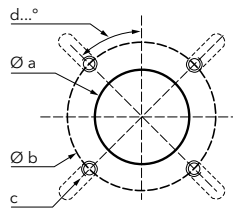

PACKAGING

The burner is delivered on a pallet in 3 packages containing:

- burner housing
- combustion head
- gas train and filter

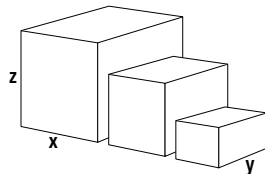

Component		Dimensions (mm)			Gross weight (kg)
		X	Y	Z	
Burner body	VG4.610 DP	490	490	590	32,7
	KN	750	260	295	8,9
Combustion head	KL	895	260	295	10,1
	d1"1/2-Rp2"	670	550	380	12
Gas train	d1"1/4-Rp1"1/4	600	400	240	11
	d3/4"-Rp1"	600	400	240	7

**VG4.610 DP**

130 ... 610 kW

2 stage progressive/modulating pneumatic (Low NOx class 3)

**PRESSURE LOSS [BURNER HEAD + GAS TRAIN] (mbar)**

**VG4.610 DP**

Burner output (kW)	Natural gas G20 Hi = 10,35 kWh/m <sup>3</sup>			Natural gas G25 Hi = 8,83 kWh/m <sup>3</sup>		
	d3/4"-Rp1"	d1"1/4-Rp1"1/4	d1"1/2-Rp2"	d3/4"-Rp1"	d1"1/4-Rp1"1/4	d1"1/2-Rp2"
350	53	9	6	78	13	7
400	70	12	8	102	17	9
450	88	16	10	129	21	11
500	109	19	12	159	26	14
550	132	23	15	192	32	17
610	162	29	18	236	39	20

**Natural gas G20**

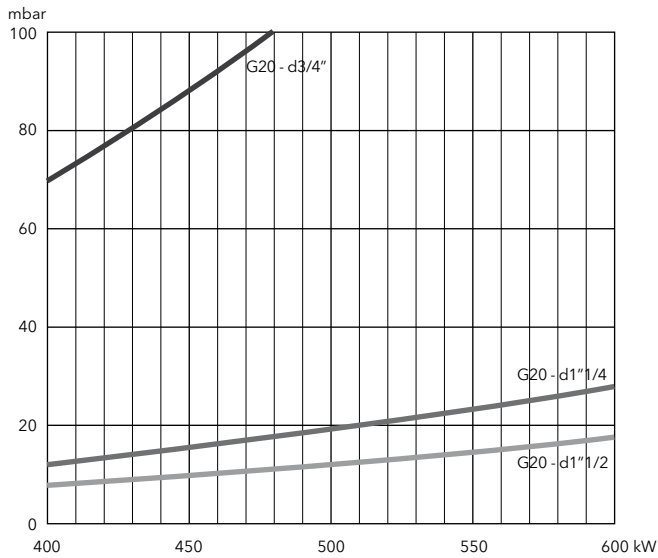

**Natural gas G25**

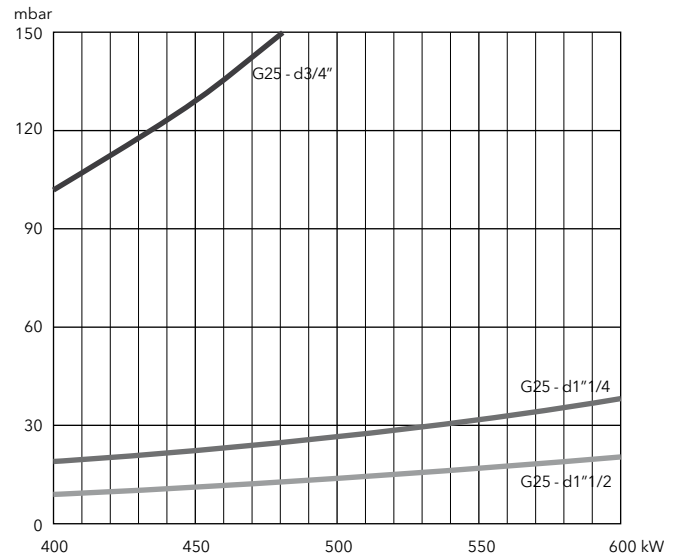





**PRESSURE LOSS [BURNER HEAD + GAS TRAIN] (mbar)**

Burner output (kW)	LPG G31 Hi = 25,89 kWh/m <sup>3</sup>	
	d3/4"-Rp1"	d1"1/2-Rp2"
350	25	8
400	32	10
450	41	13
500	50	16
550	61	20
610	75	24

**LPG**

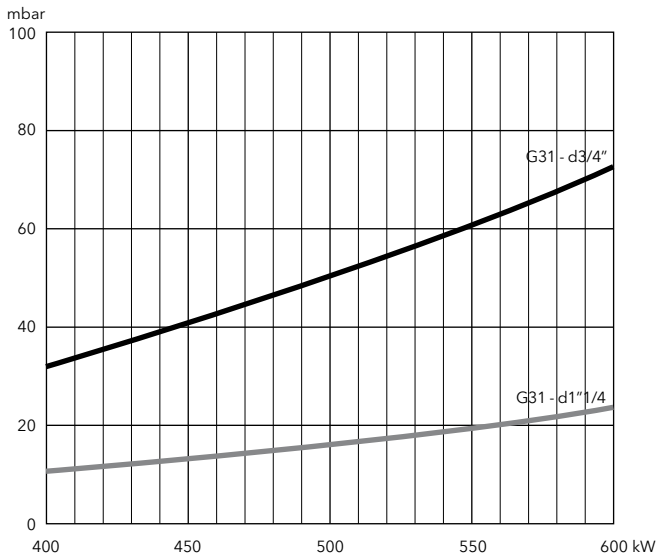

**VG5.950 DP, VG5.1200 DP**

170 ... 1160 kW  
2 stage progressive/modulating pneumatic (Low NOx class 3)

- **Fuels:** natural gas (G20/G25,  $H_u = 8,83...10,35 \text{ kWh/m}^3$ ); LPG (G31,  $H_u = 25,89 \text{ kWh/m}^3$ )
- **Emissions:** Low NOx class 3 ( $\leq 80 \text{ mg/kWh}$ ) according to EN676
- **Operation:** two stage progressive or modulating with the installation of a power regulator and dedicated probes (see pag. 180)
- **Protection level:** IP 21



**TECHNICAL DATA**

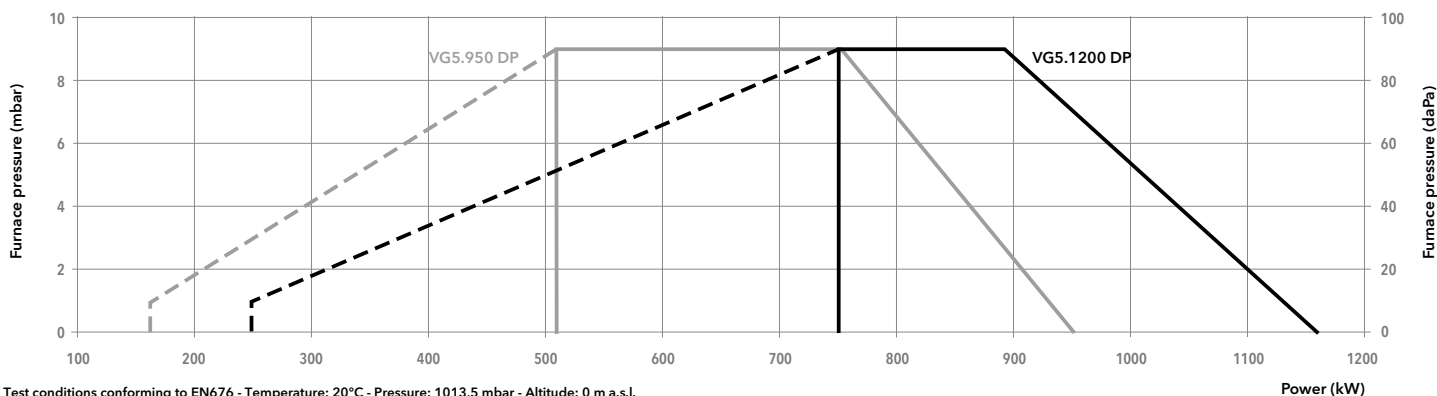

Test conditions conforming to EN676 - Temperature: 20°C - Pressure: 1013,5 mbar - Altitude: 0 m a.s.l.

Model	VG5.950 DP			VG5.1200 DP		
Operation range	(170) 510 - 950 kW			(250) 750 - 1160 kW		
Gas pressure	20 - 300 mbar			20 - 300 mbar		
Control box / flame detection	TCG 5.. / ionization			TCG 5.. / ionization		
Fan motor	230/400 V - 50 Hz - 1,5 kW			230/400 V - 50 Hz - 1,5 kW		
Electrical consumption	65 + 1884 W			67 + 2052 W		
Acoustic level (LpA)	77 dB(A)			77 dB(A)		
CE certificate	1312 CN 5684			1312 CN 5684		
Head lenght	KN	KL	KM	KN	KL	KM
Complete burner code	VGD 40-065 s65-DN65	-	-	3833603	3833604	3833629
	VGD 20-5011 s2"-Rp2"	3833595	3833596	3833597	3833598	3833631
	MB-VEF 420 d1 1/2-Rp2"	3833585	3833586	3833623	3833589	3833633
	MB-VEF 412 d1 1/4-Rp2"	3833579	3833580	3833625	3833581	3833635
	MB-VEF 407 d3/4"-Rp1"	3833583	3833584	3833627	-	-

**OTHER AVAILABLE VERSIONS**

- 60 60 Hz version
- TC Version with tightness control
- V<sub>vent</sub> Versions for continuous ventilation and post-ventilation

**SCOPE OF SUPPLY**

- The burner is delivered in its package complete with:
- 1 burner head with flange seal and securing screws
  - 1 compact gas train with gas filter; the gas filter is built-in for threaded valves (up to 2") and separated for flanged ones (DN65/80/100)
  - 1 bag containing installation fittings
  - 1 bag containing technical documentation (instruction manual, technical data, electrical diagram, exploded view and spare parts list)



**DIMENSIONS (mm)**

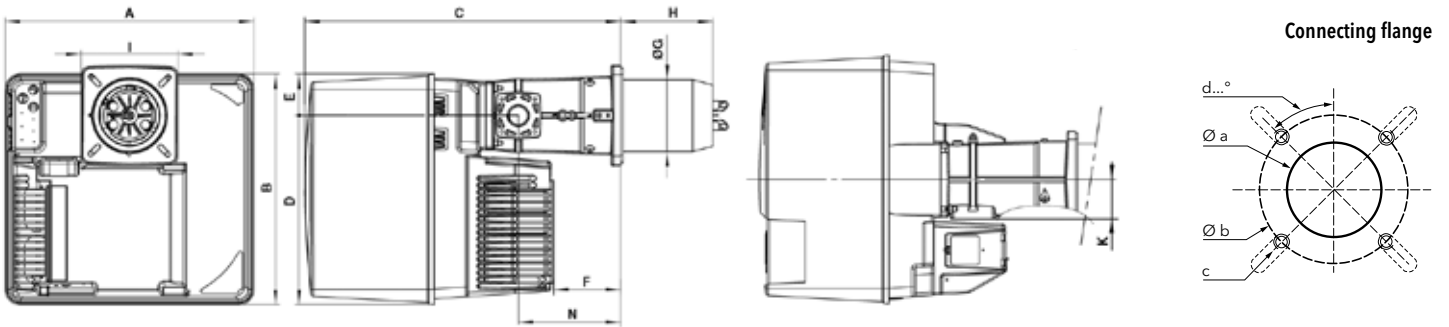

A	B	C	D	E	F	ØG	H			I	K	N
							KN	KM	KL			
581	549	752	450	99	164	170	215	325	435	230x238	89	244

Øa (mm)	b (mm)	c	d
195	220-260	M10	45°

**Gas trains**

Gas train "d":

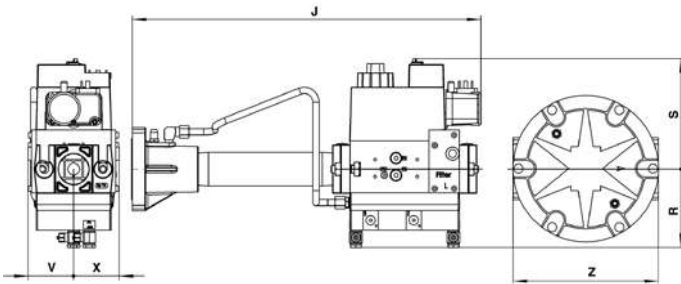

Model	J	R	S	V	X	Z
d1"1/2-Rp2"	540	123	190	55	55	-
d1"1/4-Rp2"	450	100	141	58	58	186
d3/4"-Rp1"	420	100	122	55	50	160

Gas train "s":

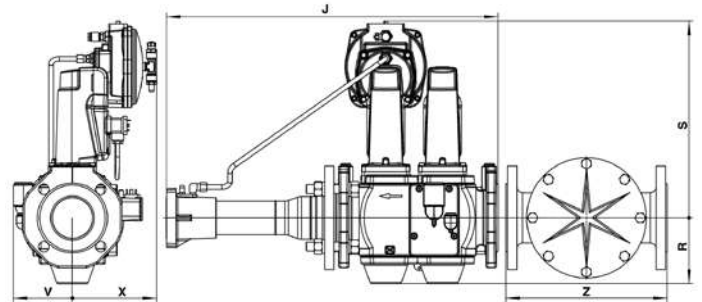

Model	J	R	S	V	X	Z
s65-DN65	600	135	360	110	150	290
s2"-Rp2"	612	103	330	110	150	186

**PACKAGING**

The burner is delivered on a pallet in 3 packages containing:

- burner housing
- combustion head
- gas train and filter

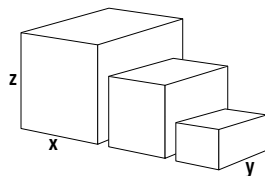

Component		Dimensions (mm)			Gross weight (kg)
		X	Y	Z	
Burner body	VG5.950 DP	800	600	850	53
	VG5.1200 DP	800	600	850	54
Combustion head	KN	780	265	280	12,3
	KL	1010	265	280	14,4
	KM	1010	265	280	13,4
Gas train	s65-DN65	790	600	500	29
	s2"-Rp2"	790	600	500	17,2
	d1"1/2-Rp2"	670	550	380	12
	d1"1/4-Rp2"	600	400	240	12
	d3/4"-Rp1"	600	400	240	7

**VG5.950 DP, VG5.1200 DP**

170 ... 1160 kW  
2 stage progressive/modulating pneumatic (Low NOx class 3)

**PRESSURE LOSS [BURNER HEAD + GAS TRAIN] (mbar)**

**VG5.950 DP**

Burner output (kW)	Natural gas G20 Hi = 10,35 kWh/m <sup>3</sup>				Natural gas G25 Hi = 8,83 kWh/m <sup>3</sup>				LPG G31 Hi = 25,89 kWh/m <sup>3</sup>			
	d3/4"-Rp1"	d1"1/4-Rp2"	d1"1/2-Rp2"	s2"-Rp2"	d3/4"-Rp1"	d1"1/4-Rp2"	d1"1/2-Rp2"	s2"-Rp2"	d3/4"-Rp1"	d1"1/4-Rp2"	d1"1/2-Rp2"	s2"-Rp2"
550	104	32	10	7	157	46	13	10	47	16	9	9
600	122	38	11	9	186	54	16	12	56	19	11	11
650	145	45	13	11	219	64	19	14	66	22	13	13
700	168	52	15	12	253	74	22	16	76	25	14	14
750	193	60	18	14	292	85	25	18	88	28	16	16
800	219	68	21	16	-	96	29	21	99	32	19	19
850	248	77	24	18	-	109	33	24	112	37	21	21
900	277	86	27	20	-	122	36	27	126	41	24	24
950	308	95	29	23	-	136	40	30	141	46	27	27

**Natural gas G20**

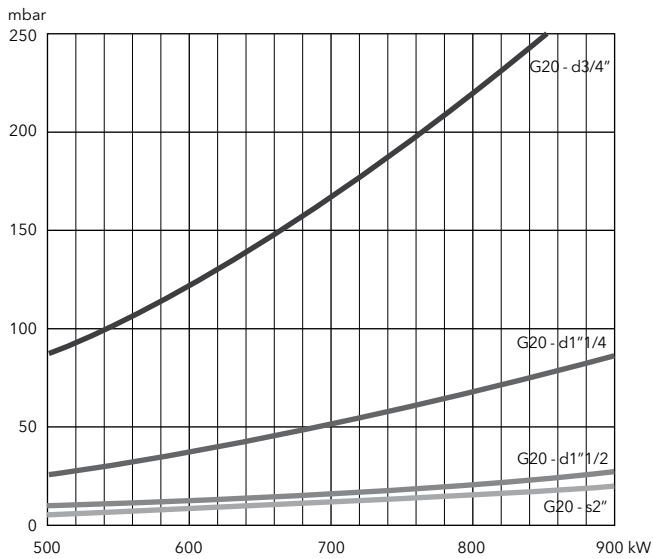

**Natural gas G25**

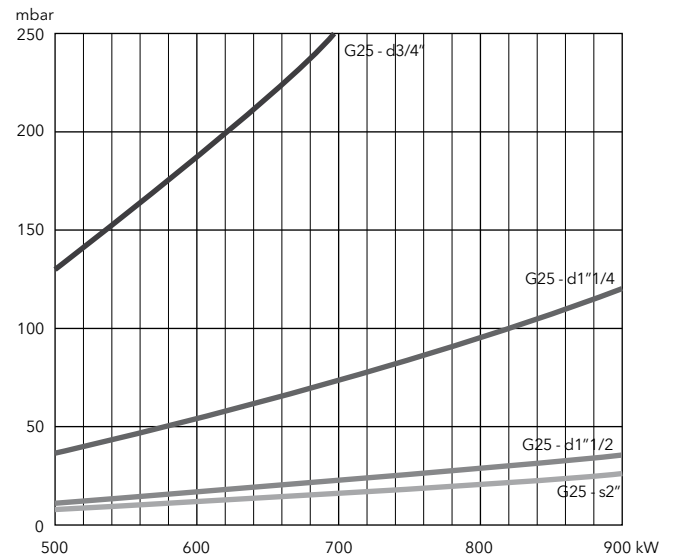

**LPG**

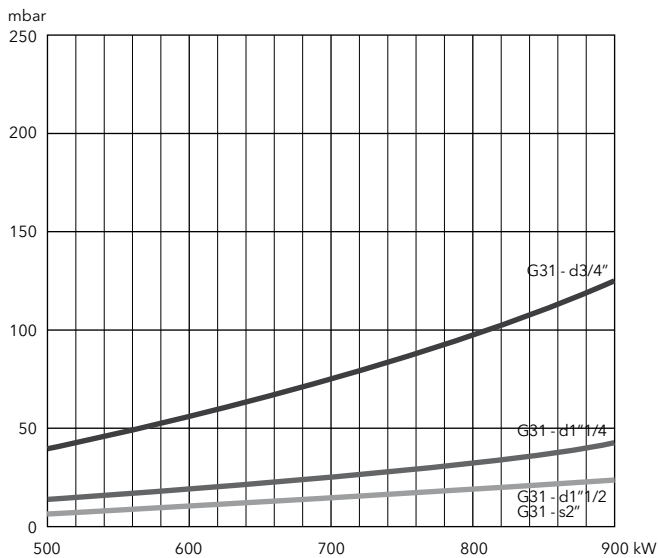



**PRESSURE LOSS [BURNER HEAD + GAS TRAIN] (mbar)**

**VG5.1200 DP**

Burner output (kW)	Natural gas G20 Hi = 10,35 kWh/m <sup>3</sup>				Natural gas G25 Hi = 8,83 kWh/m <sup>3</sup>				LPG G31 Hi = 25,89 kWh/m <sup>3</sup>		
	d1"1/4-Rp2"	d1"1/2-Rp2"	s2"-Rp2"	s65-Rp2"	d1"1/4-Rp2"	d1"1/2-Rp2"	s2"-Rp2"	s65-Rp2"	d1"1/4-Rp2"	d1"1/2-Rp2"	s2"-Rp2"
750	56	18	14	12	82	24	19	14	28	14	14
800	65	21	16	13	92	27	22	16	32	16	16
850	74	24	18	15	105	30	25	18	36	18	18
900	83	27	20	17	118	33	28	20	41	20	20
950	94	30	22	19	131	37	31	23	46	22	22
1000	103	33	25	21	145	42	34	26	51	24	25
1050	113	37	27	23	160	47	38	28	56	27	27
1100	124	40	30	25	175	51	42	31	61	30	30
1150	136	44	33	27	192	55	46	34	67	33	33

**Natural gas G20**

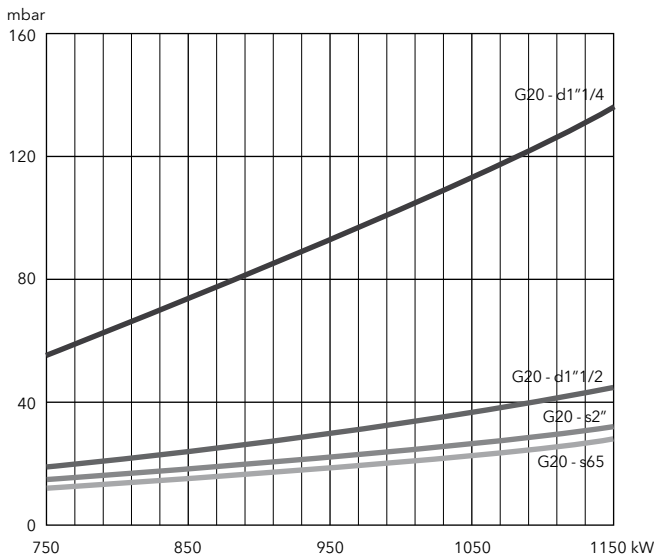

**Natural gas G25**

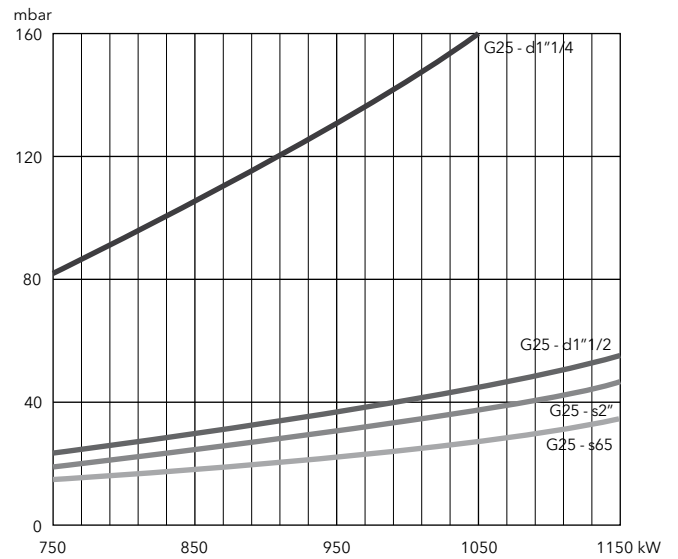

**LPG**

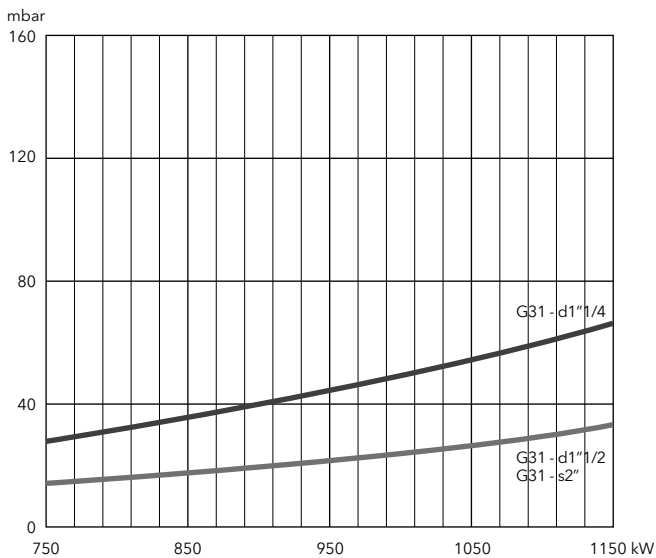

**VG6.1600 DP, VG6.2100 DP**

300 ... 1900 kW  
2 stage progressive/modulating pneumatic (Low NOx class 3)

- **Fuels:** natural gas (G20/G25,  $H_u = 8,83...10,35 \text{ kWh/m}^3$ );  
LPG (G31,  $H_u = 25,89 \text{ kWh/m}^3$ )
- **Emissions:** Low NOx class 3 ( $\leq 80 \text{ mg/kWh}$ ) according to EN676
- **Operation:** two stage progressive or modulating with the installation of a power regulator and dedicated probes (see pag. 180)
- **Protection level:** IP 21



**TECHNICAL DATA**

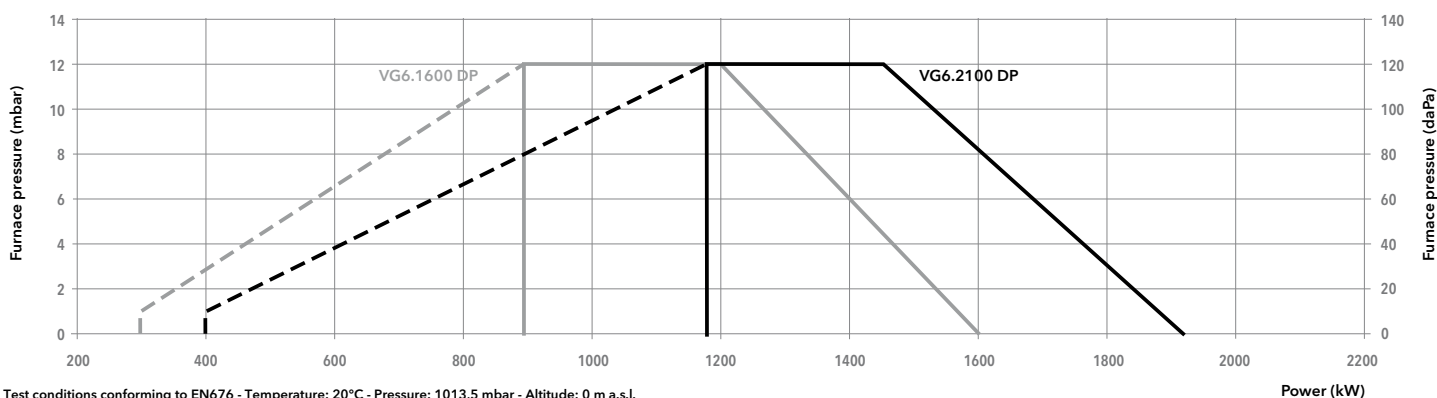

Test conditions conforming to EN676 - Temperature: 20°C - Pressure: 1013,5 mbar - Altitude: 0 m a.s.l.

Model	VG6.1600 DP /TC			VG6.2100 DP /TC			
Operation range	(300) 890 - 1600 kW			(400) 1180 - 1900 kW			
Gas pressure	20 - 300 mbar			20 - 300 mbar			
Control box / flame detection	TCG 5.. / ionization			TCG 5.. / ionization			
Fan motor	230/400 V - 50 Hz - 2,2 kW			230/400 V - 50 Hz - 2,7 kW			
Electrical consumption	76 + 2325 W			74 + 2622 W			
Acoustic level (LpA)	77,2 dB(A)			79 dB(A)			
CE certificate	1312 CN 5685			1312 CN 5685			
Head lenght	KN	KL	KM	KN	KL	KM	
Complete burner code	VGD 40-080 s80-DN80/TC	-	-	-	3833757	3833758	3833759
	VGD 40-065 s65-DN65/TC	3833745	3833746	3833747	3833760	3833761	3833762
	VGD 20-5011 s2"-Rp2"/TC	3833748	3833749	3833750	3833763	3833764	3833765
	MB-VEF 420 d1"1/2-Rp2"/TC	3833751	3833752	3833753	3833766	3833767	3833768
	MB-VEF 412 d1"1/4-Rp2"/TC	3833754	3833755	3833756	3833769	3833770	3833771

**OTHER AVAILABLE VERSIONS**

- 60 60 Hz version
- V<sub>ent</sub> Versions for continuous ventilation and post-ventilation

**SCOPE OF SUPPLY**

- The burner is delivered in its package complete with:
- 1 burner head with flange seal and securing screws
  - 1 compact gas train with gas filter; the gas filter is built-in for threaded valves (up to 2") and separated for flanged ones (DN65/80/100)
  - 1 bag containing installation fittings
  - 1 bag containing technical documentation (instruction manual, technical data, electrical diagram, exploded view and spare parts list)



**DIMENSIONS (mm)**

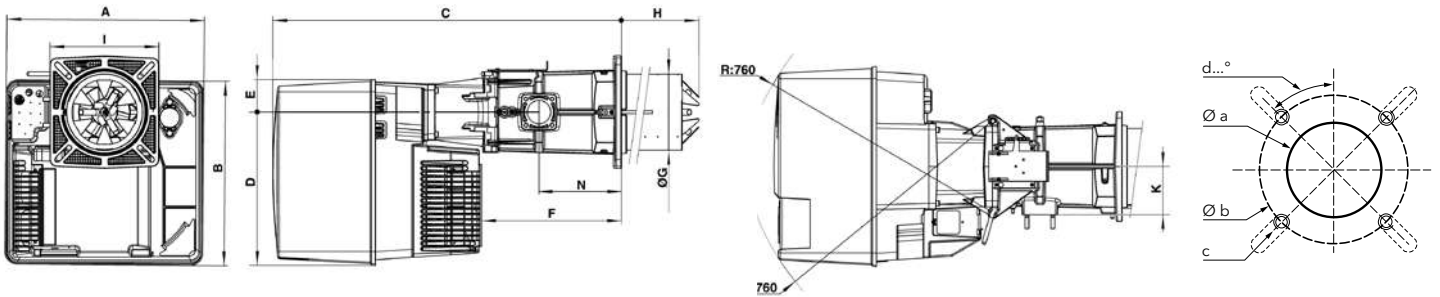

A	B	C	D	E	F	ØG	H			I	K	N
							KN	KM	KL			
592	553	1050	456	97	421	227	360	460	560	326x335	144	247

Øa (mm)	b (mm)	c	d
250	300-400	M12	45°

**Gas trains**

Gas train "d":

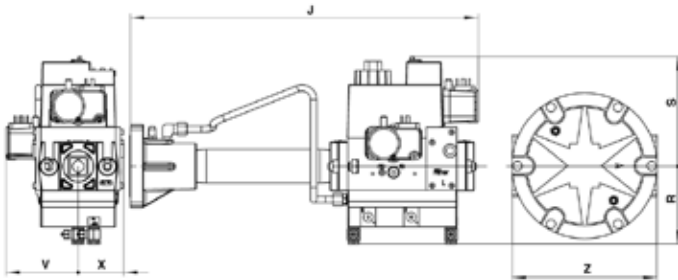

Model	J	R	S	V	X	Z
d1"1/2-Rp2"/TC	540	123	190	95	55	-
d1"1/4-Rp2"/TC	450	100	141	95	58	186

Gas train "s":

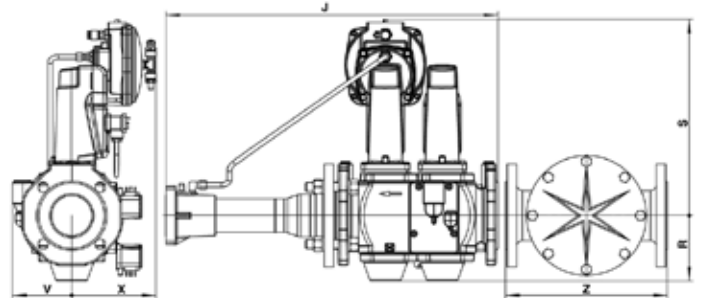

Model	J	R	S	V	X	Z
s80-DN80/TC	600	120	350	110	150	320
s65-DN65/TC	600	135	360	110	150	290
s2"-Rp2"/TC	612	103	330	110	150	186

**PACKAGING**

The burner is delivered on a pallet in 3 packages containing:

- burner housing
- combustion head
- gas train and filter

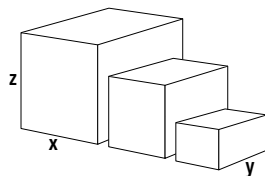

Component		Dimensions (mm)			Gross weight (kg)
		X	Y	Z	
Burner body	VG6.1600 DP	800	600	850	67,8
	VG6.2100 DP	800	600	850	69,2
Combustion head	KN	1000	380	420	26,7
	KL	1100	380	430	29,4
	KM	1100	380	430	28
Gas train	s80-DN80/TC	790	600	500	39
	s65-DN65/TC	790	600	500	29,4
	s2"-Rp2"/TC	790	600	500	16,5
	d1"1/2-Rp2"/TC	670	550	380	14,3
	d1"1/4-Rp2"/TC	670	550	380	13



**VG6.1600 DP, VG6.2100 DP**

300 ... 1900 kW  
2 stage progressive/modulating pneumatic (Low NOx class 3)

**PRESSURE LOSS [BURNER HEAD + GAS TRAIN] (mbar)**

**VG6.1600 DP**

Burner output (kW)	Natural gas G20 Hi = 10,35 kWh/m <sup>3</sup>				Natural gas G25 Hi = 8,83 kWh/m <sup>3</sup>				LPG G31 Hi = 25,89 kWh/m <sup>3</sup>		
	d1"1/4-Rp2"	d1"1/2-Rp2"	s2"-Rp2"	s65-DN65	d1"1/4-Rp2"	d1"1/2-Rp2"	s2"-Rp2"	s65-DN65	d1"1/4-Rp2"	d1"1/2-Rp2"	s2"-Rp2"
900	53	18	9	7	77	27	14	9	20	8	6
1000	66	23	12	8	93	33	17	12	24	10	7
1100	80	28	14	10	113	40	21	14	29	12	9
1200	95	33	17	12	136	48	25	17	35	15	10
1300	112	39	20	14	158	57	29	20	41	17	12
1400	129	45	23	16	182	66	34	23	47	20	14
1500	148	51	26	19	209	76	39	27	54	23	16
1600	168	58	30	21	238	86	45	30	62	26	19

**Natural gas G20**

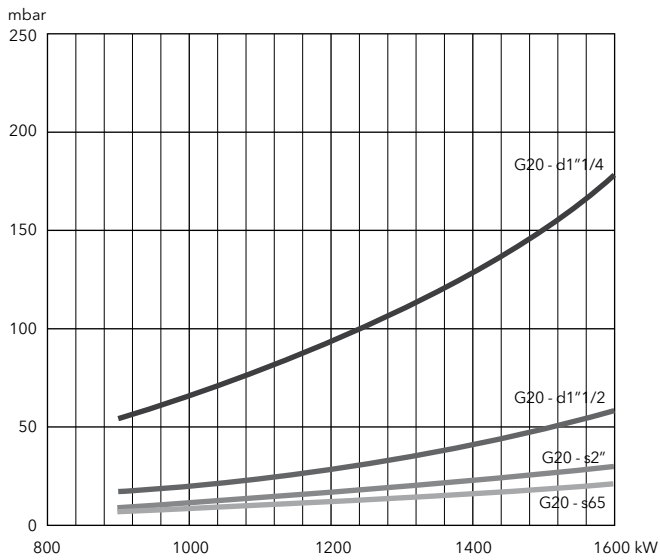

**Natural gas G25**

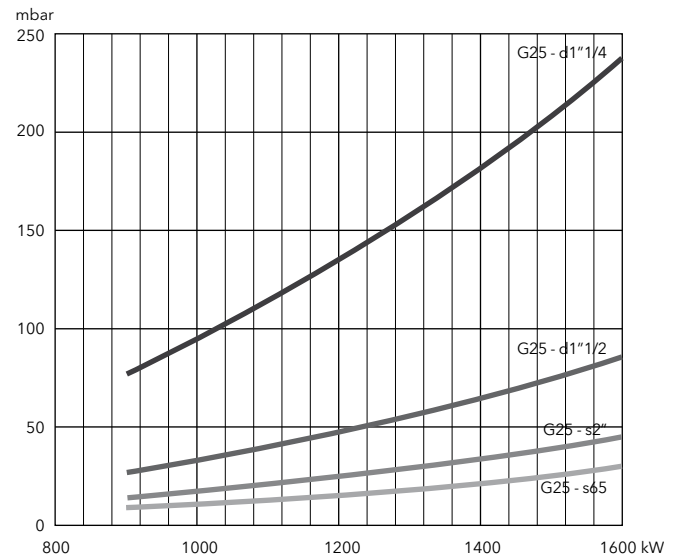

**LPG**

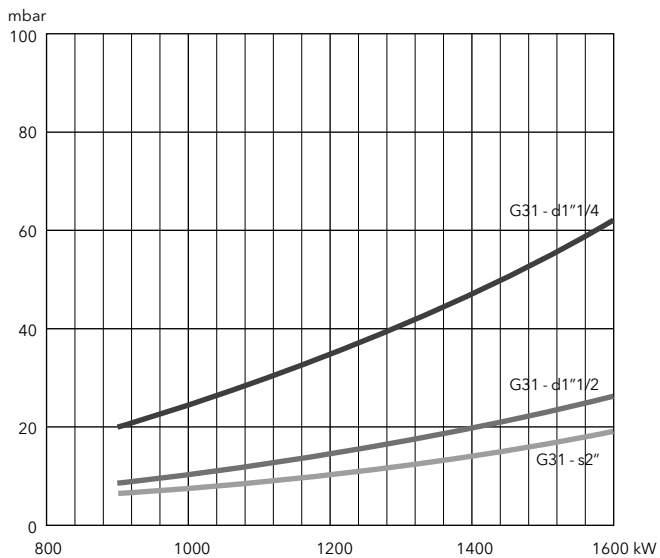



**PRESSURE LOSS [BURNER HEAD + GAS TRAIN] (mbar)**

**VG6.2100 DP**

Burner output (kW)	Natural gas G20 Hi = 10,35 kWh/m <sup>3</sup>					Natural gas G25 Hi = 8,83 kWh/m <sup>3</sup>					LPG G31 Hi = 25,89 kWh/m <sup>3</sup>		
	d1"1/4-Rp2	d1"1/2-Rp2	s2"-Rp2"	s65-DN65	s80-DN80	d1"1/4-Rp2	d1"1/2-Rp2	s2"-Rp2"	s65-DN65	s80-DN80	d1"1/4-Rp2	d1"1/2-Rp2	s2"-Rp2"
1200	70	28	17	12	10	81	32	20	14	12	39	13	8
1300	82	32	20	14	12	95	38	24	16	14	46	15	10
1400	95	37	24	16	14	110	44	28	19	16	53	17	11
1500	109	43	27	18	16	128	50	32	21	19	61	20	13
1600	124	49	31	21	18	144	57	36	24	21	69	23	15
1700	140	55	35	24	21	163	64	40	27	24	78	26	17
1800	157	61	39	26	23	183	71	45	30	27	87	29	19
1900	175	69	43	29	25	204	79	50	34	31	97	32	21

**Natural gas G20**

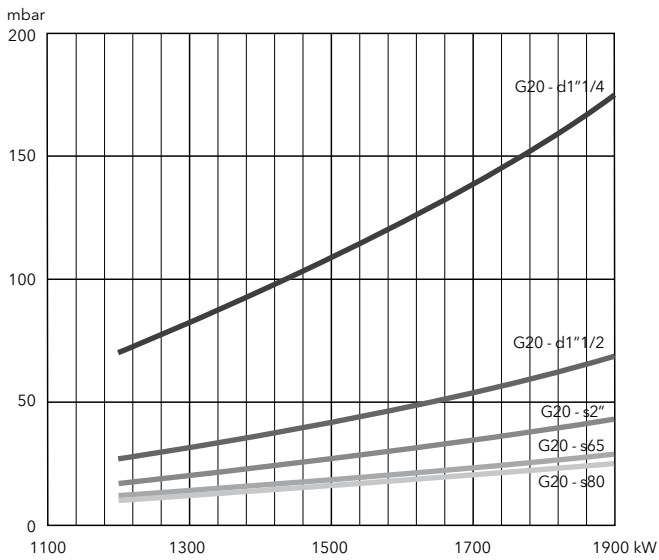

**Natural gas G25**

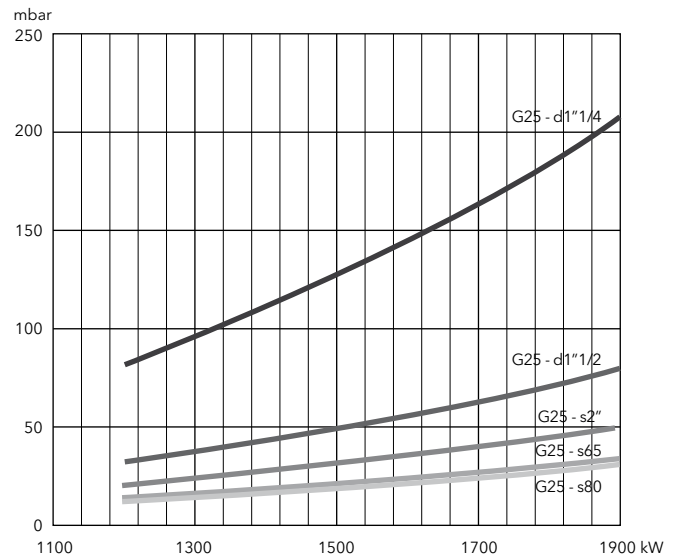

**LPG**

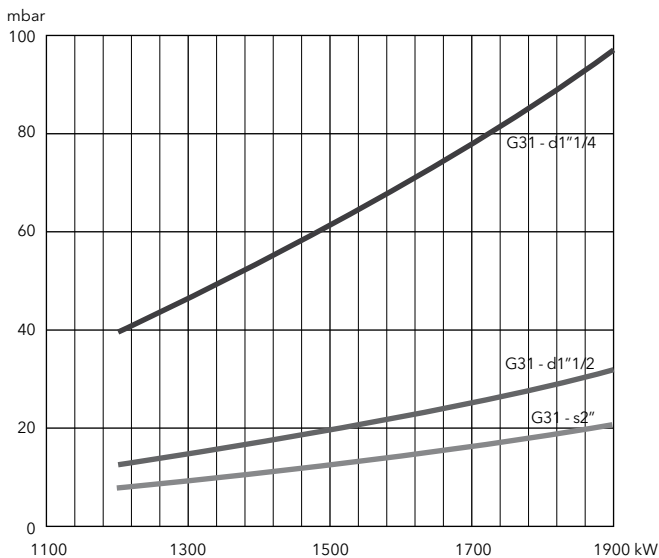

**VG5.950 DP R, VG5.1200 DP R**

150 ... 1200 kW

2 stage progressive/modulating pneumatic

- **Fuels:** natural gas (G20/G25,  $H_u = 8,83...10,35 \text{ kWh/m}^3$ ); LPG (G31,  $H_u = 25,89 \text{ kWh/m}^3$ )
- **Emissions:** Low NO<sub>x</sub> class 2 ( $\leq 120 \text{ mg/kWh}$ ) according to EN676
- **Operation:** two stage progressive or modulating with the installation of a power regulator and dedicated probes (see pag. 180)
- **Protection level:** IP 21



**TECHNICAL DATA**

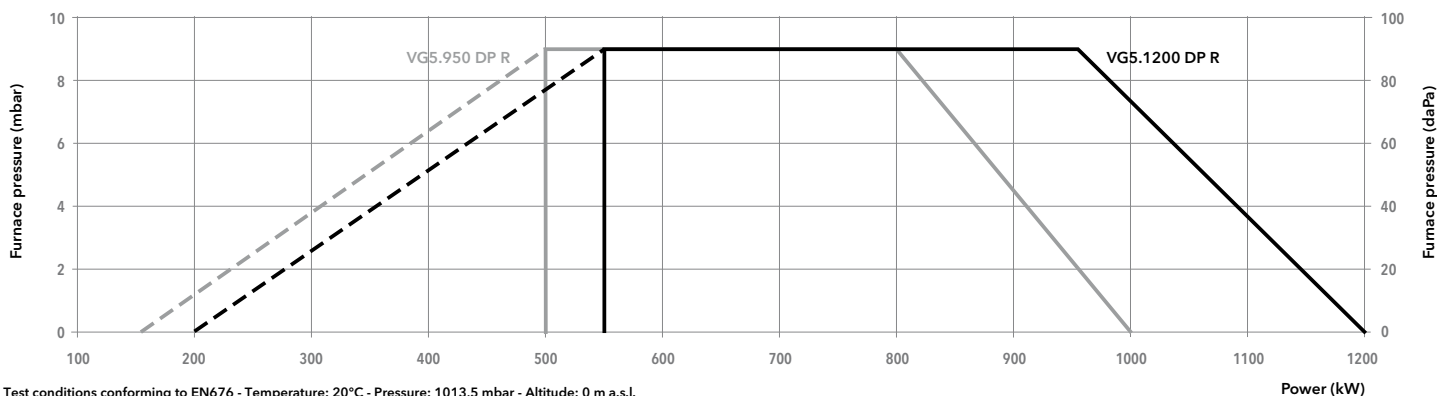

Test conditions conforming to EN676 - Temperature: 20°C - Pressure: 1013,5 mbar - Altitude: 0 m a.s.l.

Model	VG5.950 DP R			VG5.1200 DP R		
Operation range	(150) 500 - 1000 kW			(200) 550 - 1200 kW		
Gas pressure	20 - 500 mbar			20 - 500 mbar		
Control box / flame detection	TCG 5.. / ionization			TCG 5.. / ionization		
Fan motor	230/400 V - 50 Hz - 1,5 kW			230/400 V - 50 Hz - 1,5 kW		
Electrical consumption	100 + 2200 W			100 + 2300 W		
Acoustic level (LpA)	77 dB(A)			77 dB(A)		
CE certificate	0085 CQ 0570			0085 CQ 0570		
Head lenght	KN	KL	KM	KN	KL	KM
Complete burner code	VGD 40-065 s65-DN65	-	-	3835377	3835378	3835379
	VGD 20-5011 s2"-Rp2"	3835357	3835366	3835380	3835381	3835382
	MB-VEF 420 d1"1/2-Rp2"	3835368	3835369	3835370	3835383	3835384
	MB-VEF 412 d1"1/4-Rp2"	3835371	3835372	3835373	3835386	3835387
	MB-VEF 407 d3/4"-Rp1"	3835374	3835375	3835376	-	-

**OTHER AVAILABLE VERSIONS**

- 60 60 Hz version
- TC Version with tightness control
- V<sub>vent</sub> Versions for continuous ventilation and post-ventilation

**SCOPE OF SUPPLY**

The burner is delivered in its package complete with:

- 1 burner head with flange seal and securing screws
- 1 compact gas train with gas filter; the gas filter is built-in for threaded valves (up to 2") and separated for flanged ones (DN65/80/100)
- 1 bag containing installation fittings
- 1 bag containing technical documentation (instruction manual, technical data, electrical diagram, exploded view and spare parts list)

**DIMENSIONS (mm)**

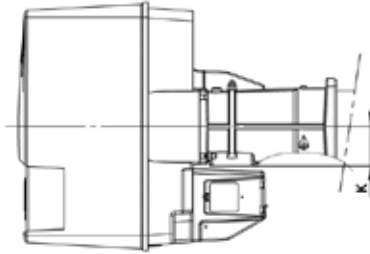
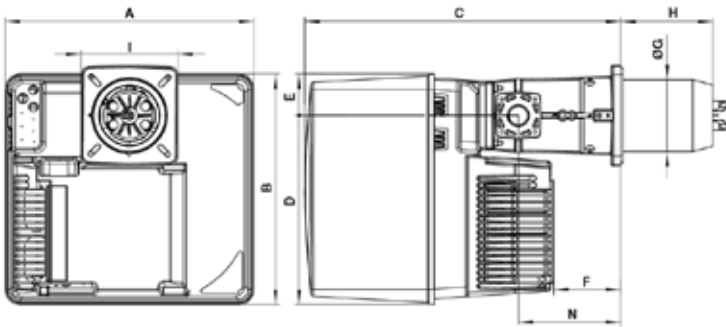

Connecting flange

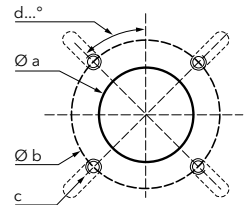

A	B	C	D	E	F	ØG	H			I	K	N
							KN	KM	KL			
581	549	752	450	99	164	170	215	325	435	230x238	89	244

Øa (mm)	b (mm)	c	d
195	220-260	M10	45°

**Gas trains**

Gas train "d":

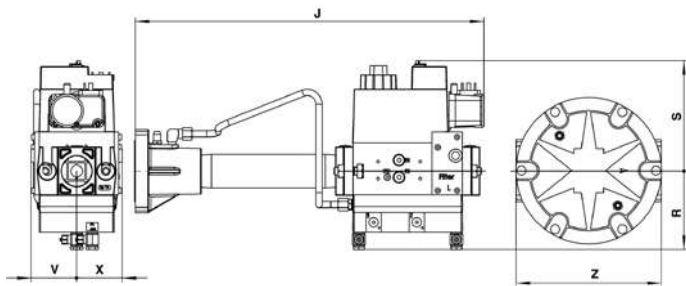

Model	J	R	S	V	X	Z
d1"1/2-Rp2"	540	123	190	55	55	-
d1"1/4-Rp2"	450	100	141	58	58	186
d3/4"-Rp1"	420	100	122	55	50	160

Gas train "s":

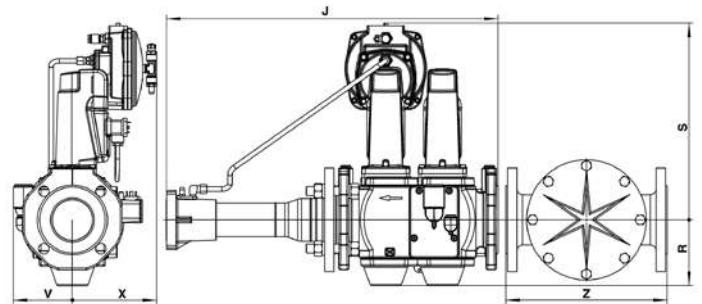

Model	J	R	S	V	X	Z
s65-DN65	600	135	360	110	150	290
s2"-Rp2"	612	103	330	110	150	186

**PACKAGING**

The burner is delivered on a pallet in 3 packages containing:

- burner housing
- combustion head
- gas train and filter

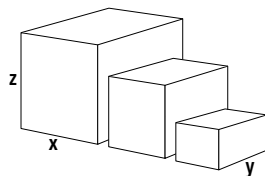

Component		Dimensions (mm)			Gross weight (kg)
		X	Y	Z	
Burner body	VG5.950 DP R	800	600	850	55
	VG5.1200 DP R	800	600	850	56
Combustion head	KN	780	265	280	12,3
	KL	1010	265	280	14,4
	KM	1010	265	280	13,4
Gas train	s65-DN65	670	530	380	29
	s2"-Rp2"	670	530	380	17,2
	d1"1/2-Rp2"	400	570	200	12
	d1"1/4-Rp2"	590	390	180	12
	d3/4"-Rp1"	590	390	180	7

**VG5.950 DP R, VG5.1200 DP R**

150 ... 1200 kW

2 stage progressive/modulating pneumatic

**PRESSURE LOSS [BURNER HEAD + GAS TRAIN] (mbar)**

**VG5.950 DP R**

Burner output (kW)	Natural gas G20 Hi = 10,35 kWh/m <sup>3</sup>				Natural gas G25 Hi = 8,83 kWh/m <sup>3</sup>				LPG G31 Hi = 25,89 kWh/m <sup>3</sup>			
	d3/4"-Rp1"	d1"1/4-Rp2"	d1"1/2-Rp2"	s2"-Rp2"	d3/4"-Rp1"	d1"1/4-Rp2"	d1"1/2-Rp2"	s2"-Rp2"	d3/4"-Rp1"	d1"1/4-Rp2"	d1"1/2-Rp2"	s2"-Rp2"
500	87	18	11	7	129	26	15	11	40	11	8	7
600	120	24	14	10	179	36	21	15	55	15	11	9
700	167	34	20	14	248	51	30	21	77	21	15	13
800	214	43	25	18	-	65	38	27	98	27	19	16
900	-	56	33	23	-	83	48	34	126	35	25	21
1000	-	68	40	28	-	101	59	42	153	42	30	26

**Natural gas G20**

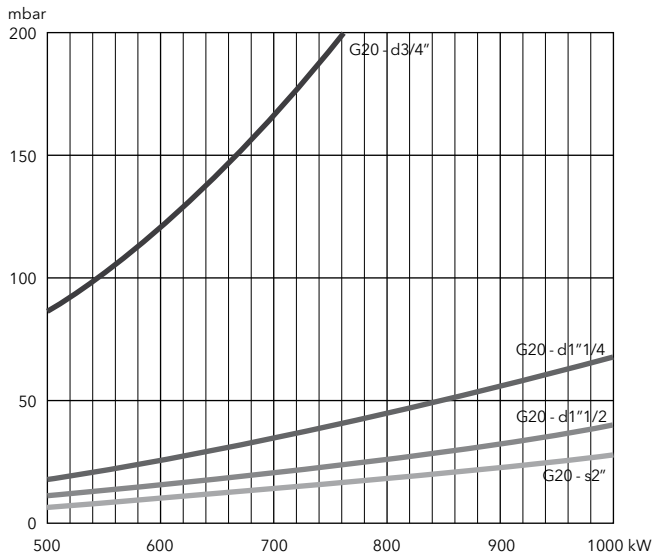

**Natural gas G25**

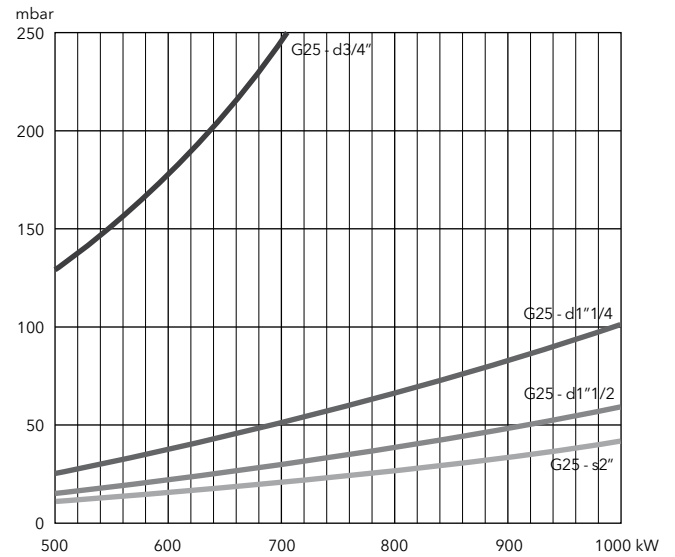

**LPG**

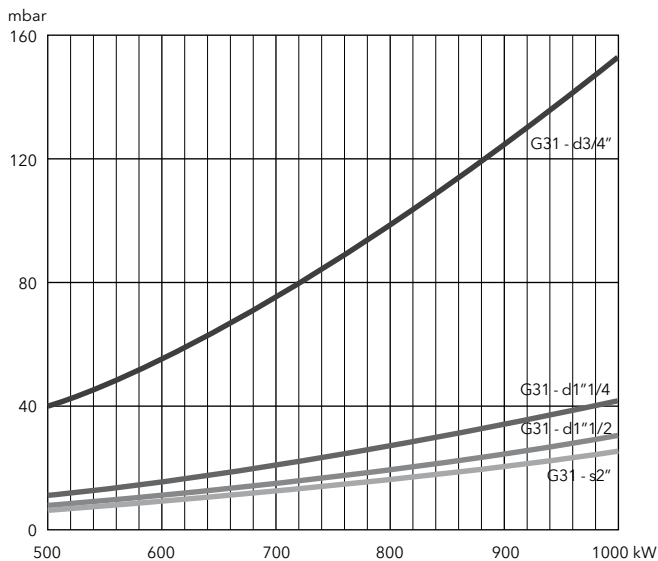



**PRESSURE LOSS [BURNER HEAD + GAS TRAIN] (mbar)**

**VG5.1200 DP R**

Burner output (kW)	Natural gas G20 Hi = 10,35 kWh/m <sup>3</sup>				Natural gas G25 Hi = 8,83 kWh/m <sup>3</sup>				LPG G31 Hi = 25,89 kWh/m <sup>3</sup>		
	d1"1/4-Rp2"	d1"1/2-Rp2"	s2"-Rp2"	s65-Rp2"	d1"1/4-Rp2"	d1"1/2-Rp2"	s2"-Rp2"	s65-Rp2"	d1"1/4-Rp2"	d1"1/2-Rp2"	s2"-Rp2"
700	30	16	10	8	45	24	16	12	16	10	8
800	39	21	14	10	58	32	20	16	21	13	10
900	50	27	18	13	74	40	26	20	26	17	13
1000	61	33	21	16	91	49	32	25	33	21	16
1100	74	40	26	20	110	60	39	30	40	26	19
1200	88	48	31	24	132	71	46	35	47	30	23

**Natural gas G20**

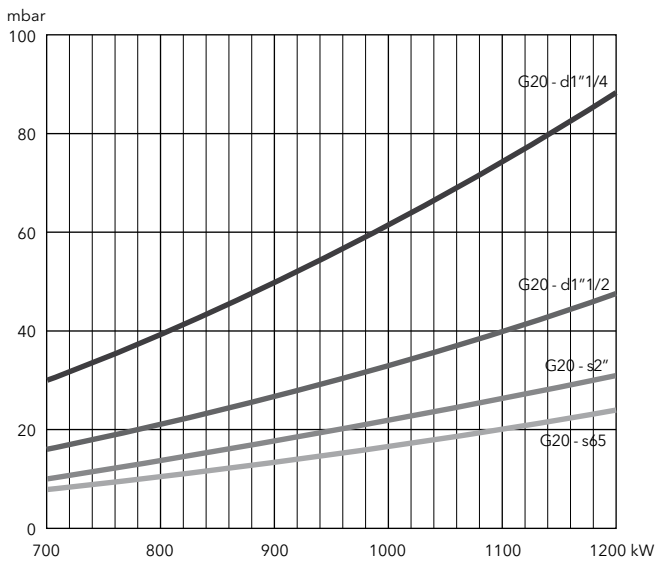

**Natural gas G25**

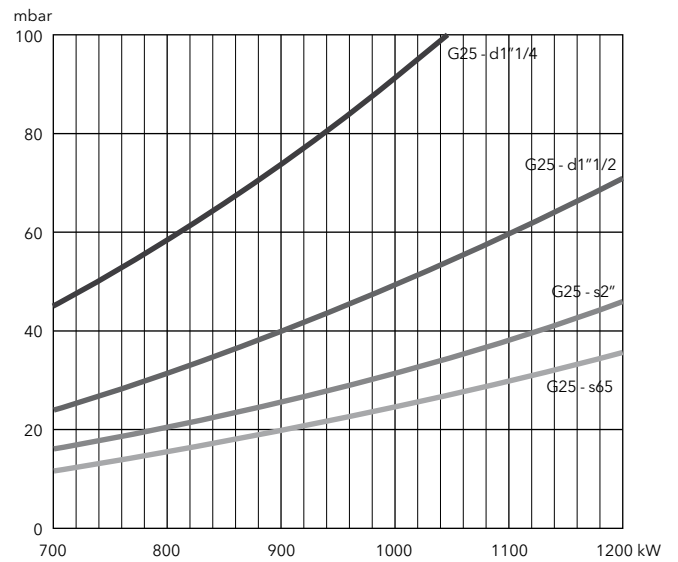

**LPG**

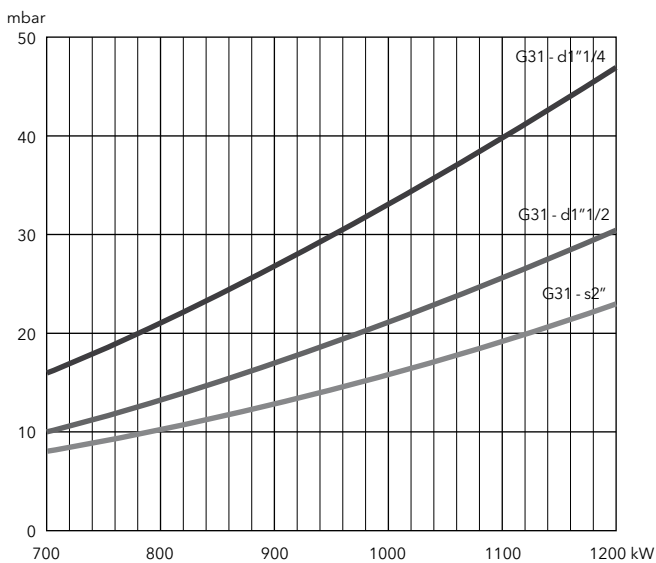

**VG6.1600 DP R, VG6.2100 DP R**

200 ... 2300 kW  
2 stage progressive/modulating pneumatic

- **Fuels:** natural gas (G20/G25,  $H_u = 8,83...10,35 \text{ kWh/m}^3$ );  
LPG (G31,  $H_u = 25,89 \text{ kWh/m}^3$ )
- **Emissions:** Low NOx class 2 ( $\leq 120 \text{ mg/kWh}$ ) according to EN676
- **Operation:** two stage progressive or modulating with the installation of a power regulator and dedicated probes (see pag. 180)
- **Protection level:** IP 21



**TECHNICAL DATA**

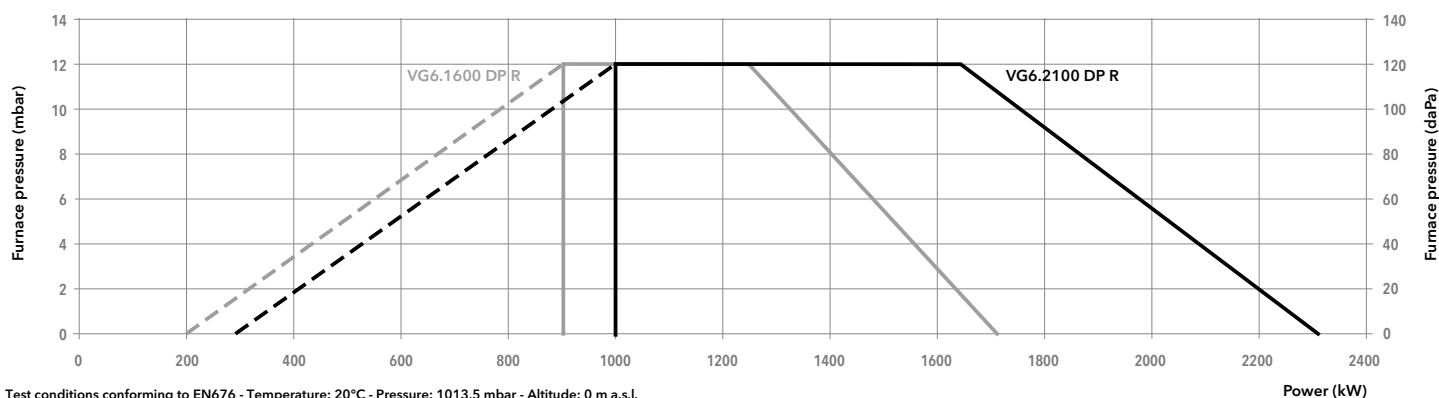

Test conditions conforming to EN676 - Temperature: 20°C - Pressure: 1013,5 mbar - Altitude: 0 m a.s.l.

Model	VG6.1600 DP R /TC			VG6.2100 DP R /TC			
Operation range	(200) 900 - 1700 kW			(300) 1000- 2300 kW			
Gas pressure	20 - 500 mbar			20 - 500 mbar			
Control box / flame detection	TCG 5.. / ionization			TCG 5.. / ionization			
Fan motor	230/400 V - 50 Hz - 2,2 kW			230/400 V - 50 Hz - 2,7 kW			
Electrical consumption	100 + 2500 W			100 + 3500 W			
Acoustic level (LpA)	77 dB(A)			79 dB(A)			
CE certificate	0085 CQ 0570			0085 CQ 0570			
Head lenght	KN	KL	KM	KN	KL	KM	
Complete burner code	VGD 40-080 s80-DN80/TC	-	-	-	3835911	3835910	3835909
	VGD 40-065 s65-DN65/TC	3834801	3834802	3834803	3834813	3834814	3834815
	VGD 20-5011 s2"-Rp2"/TC	3834804	3834805	3834806	3834816	3834817	3834818
	MB-VEF 420 d1"1/2-Rp2"/TC	3834807	3834808	3834809	3834819	3834820	3834821
	MB-VEF 412 d1"1/4-Rp2"/TC	3834810	3834811	3834812	3834822	3834823	3834824

**OTHER AVAILABLE VERSIONS**

- 60 60 Hz version
- V<sub>ent</sub> Versions for continuous ventilation and post-ventilation

**SCOPE OF SUPPLY**

- The burner is delivered in its package complete with:
- 1 burner head with flange seal and securing screws
  - 1 compact gas train with gas filter; the gas filter is built-in for threaded valves (up to 2") and separated for flanged ones (DN65/80/100)
  - 1 bag containing installation fittings
  - 1 bag containing technical documentation (instruction manual, technical data, electrical diagram, exploded view and spare parts list)



**DIMENSIONS (mm)**

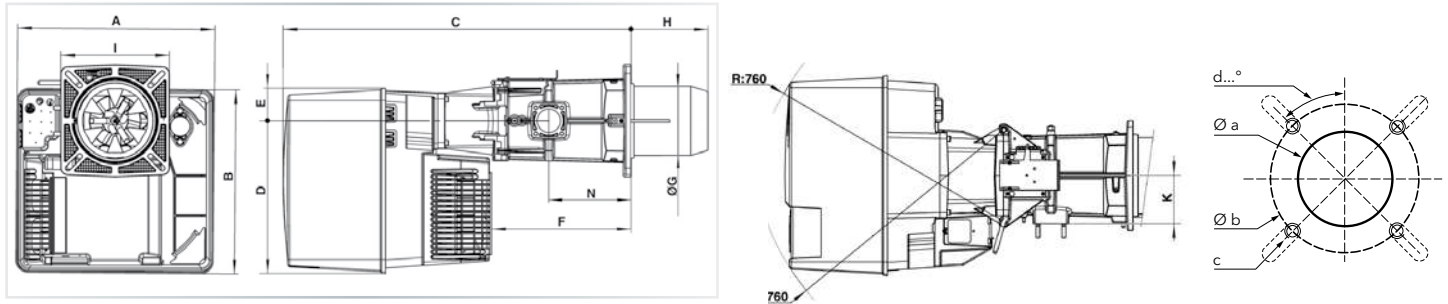

A	B	C	D	E	F	ØG	H			I	K	N
							KN	KM	KL			
592	553	1050	456	97	421	227	270	370	470	326x335	144	247

Øa (mm)	b (mm)	c	d
250	300-400	M12	45°

**Gas trains**

Gas train "d":

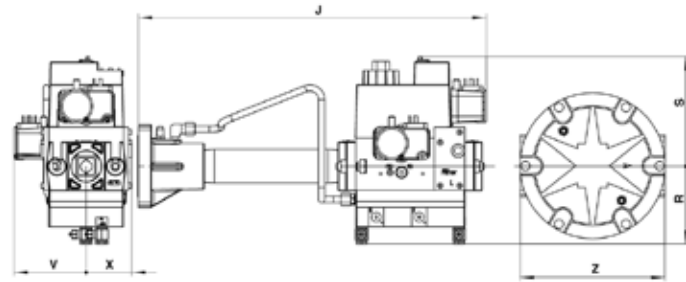

Model	J	R	S	V	X	Z
d1"1/2-Rp2"/TC	540	123	190	95	55	-
d1"1/4-Rp2"/TC	450	100	141	95	58	186

Gas train "s":

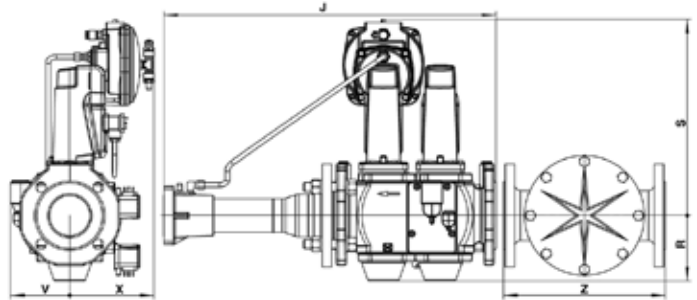

Model	J	R	S	V	X	Z
s80-DN80/TC	600	120	350	110	150	320
s65-DN65/TC	600	135	360	110	150	290
s2"-Rp2"/TC	612	103	330	110	150	186

**PACKAGING**

The burner is delivered on a pallet in 3 packages containing:

- burner housing
- combustion head
- gas train and filter

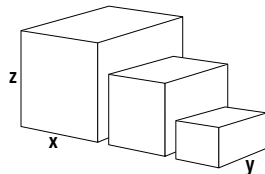

Component		Dimensions (mm)			Gross weight (kg)
		X	Y	Z	
Burner body	VG6.1600 DP R	800	600	850	67,8
	VG6.2100 DP R	800	600	850	69,2
Combustion head	KN	1000	380	420	26,7
	KL	1100	380	430	29,4
	KM	1100	380	430	28
Gas train	s80-DN80/TC	670	530	380	39
	s65-DN65/TC	670	530	380	29,4
	s2"-Rp2"/TC	670	530	380	16,5
	d1"1/2-Rp2"/TC	400	570	200	14,3
	d1"1/4-Rp2"/TC	590	390	180	13

**VG6.1600 DP R, VG6.2100 DP R**

200 ... 2300 kW

2 stage progressive/modulating pneumatic

**PRESSURE LOSS [BURNER HEAD + GAS TRAIN] (mbar)**

**VG6.1600 DP R**

Burner output (kW)	Natural gas G20 Hi = 10,35 kWh/m <sup>3</sup>				Natural gas G25 Hi = 8,83 kWh/m <sup>3</sup>				LPG G31 Hi = 25,89 kWh/m <sup>3</sup>			
	d1"1/4-Rp2"	d1"1/2-Rp2"	s2"-Rp2"	s65-DN65	d1"1/4-Rp2"	d1"1/2-Rp2"	s2"-Rp2"	s65-DN65	d1"1/4-Rp2"	d1"1/2-Rp2"	s2"-Rp2"	s65-DN65
800	34	16	8	5	52	24	12	8	16	8	5	4
1000	52	24	12	8	78	36	18	12	24	12	8	6
1200	76	35	18	11	113	53	27	17	35	18	11	8
1400	103	48	24	15	153	71	37	22	47	24	15	11
1600	135	62	32	20	202	93	48	29	62	32	19	14

**Natural gas G20**

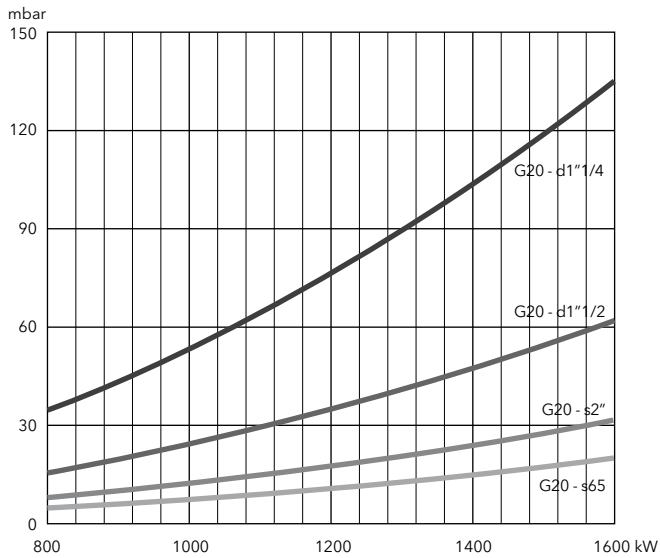

**Natural gas G25**

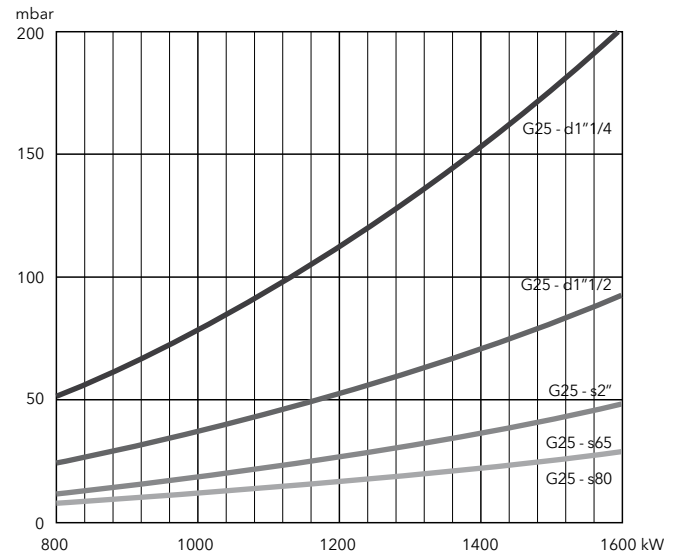

**LPG**

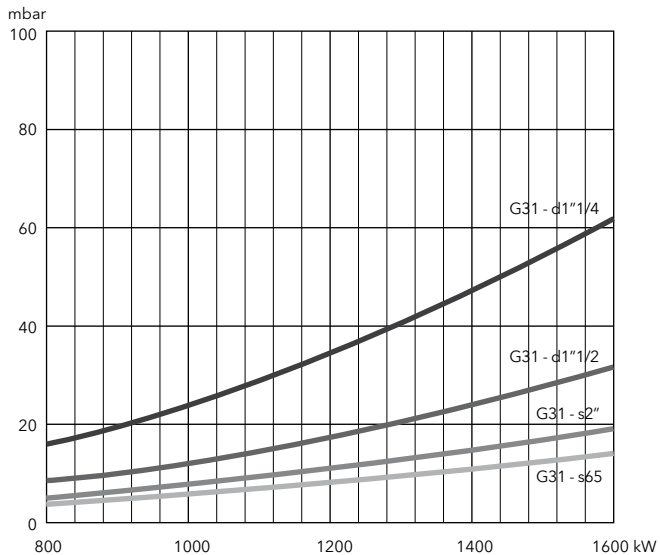

**PRESSURE LOSS [BURNER HEAD + GAS TRAIN] (mbar)**

**VG6.2100 DP R**

Burner output (kW)	Natural gas G20 Hi = 10,35 kWh/m <sup>3</sup>					Natural gas G25 Hi = 8,83 kWh/m <sup>3</sup>					LPG G31 Hi = 25,89 kWh/m <sup>3</sup>		
	d1"1/4- Rp2"	d1"1/2- Rp2"	s2"- Rp2"	s65- DN65	s80- DN80	d1"1/4- Rp2"	d1"1/2- Rp2"	s2"- Rp2"	s65- DN65	s80- DN80	d1"1/4- Rp2"	d1"1/2- Rp2"	s2"- Rp2"
1300	87	39	19	10	7	130	58	28	16	10	38	18	10
1500	114	51	25	14	9	170	76	37	21	13	50	24	13
1700	147	66	32	18	11	220	98	48	27	17	65	31	17
1900	184	83	40	22	14	274	123	60	34	21	81	38	21
2100	225	101	49	27	17	336	151	73	41	26	99	47	26
2300	269	121	58	33	21	402	180	87	49	31	119	56	30

**Natural gas G20**

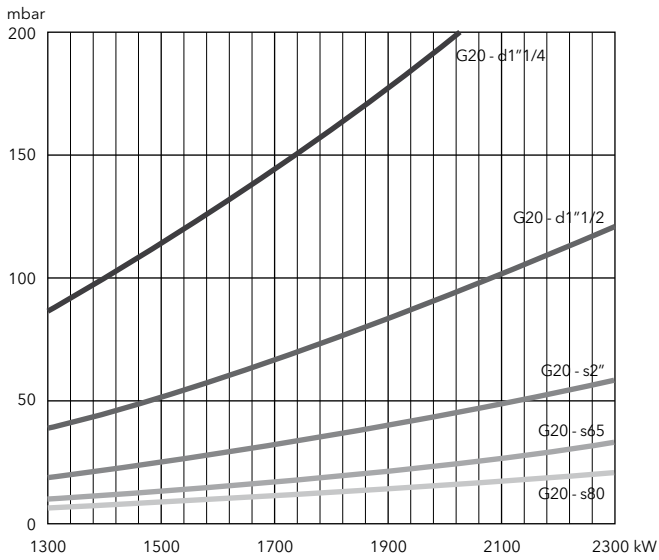

**Natural gas G25**

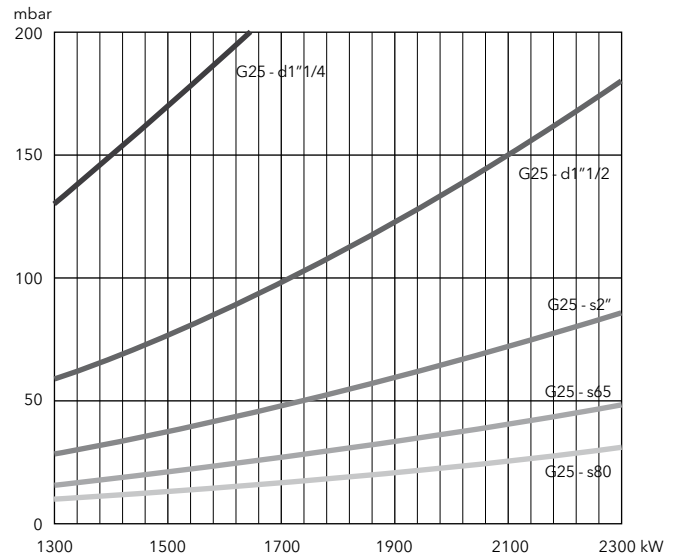

**LPG**

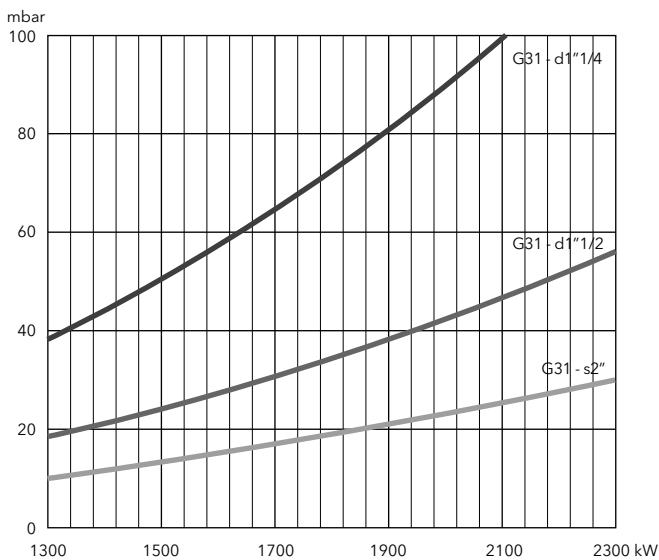

**VG2.205 V E**

65 ... 205 kW  
2 stage progressive/modulating pneumatic + fan speed control (ErP compliant)

- **Fuels:** natural gas (G20/G25,  $H_u = 8,83...10,35 \text{ kWh/m}^3$ ); LPG (G31,  $H_u = 25,89 \text{ kWh/m}^3$ )
- **Emissions:** compliant with ErP Directive
- **Operation:** two stage progressive or modulating with the installation of a power regulator and dedicated probes (see pag. 180)
- **Protection level:** IP 21



**TECHNICAL DATA**

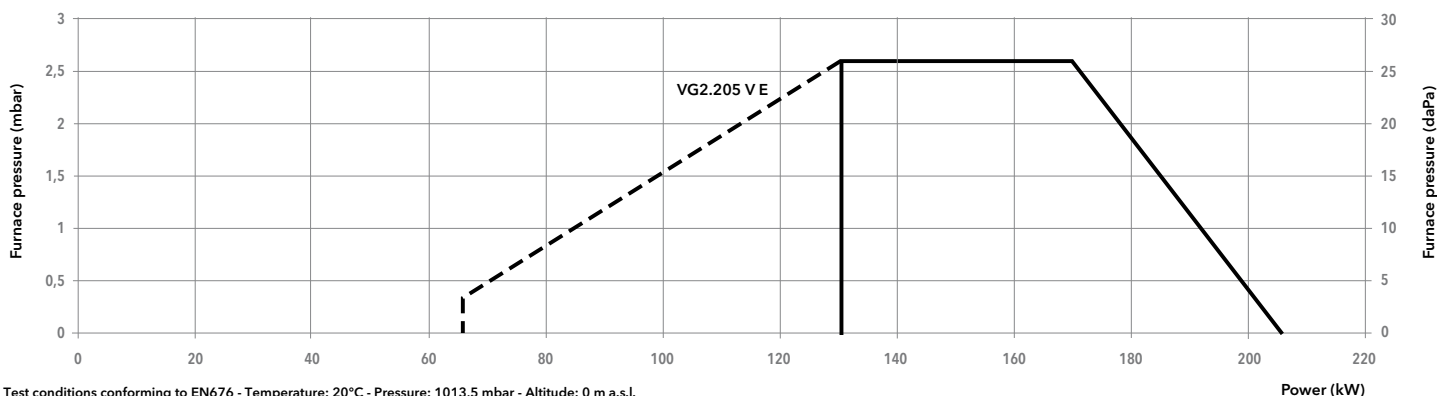

Test conditions conforming to EN676 - Temperature: 20°C - Pressure: 1013,5 mbar - Altitude: 0 m a.s.l.

Model	VG2.205 V E		
Operation range	(65) 130 - 205 kW		
Gas pressure	20 - 40 mbar for MB-VEF 412; 40 - 100 mbar for d345; 100 - 360 mbar for d346		
Control box / flame detection	TCG5.../ionization		
Fan motor	230 V - 50 Hz - 130 W		
Electrical consumption (max/min/stand-by)	302 W / 267 W / 4 W		
Acoustic level (LpA)	65 dB(A)		
CE certificate	0476 CT 2423		
Head lenght	KN		KL
Complete burner code	MB-VEF 412	d1"1/4-Rp1"1/4	3836436
	MB-VEF 407	d345-3/4"-Rp3/4"	3836438
	MB-VEF 407	d346-3/4"-Rp3/4"	3836440
			3836437
			3836439
			3836441

**OTHER AVAILABLE VERSIONS**

Versions for continuous ventilation and post-ventilation

**SCOPE OF SUPPLY**

The burner is delivered in its package complete with:

- 1 gas connection flange
- 1 compact gas train with gas filter; the gas filter is built-in for threaded valves (up to 2") and separated for flanged ones (DN65/80/100)
- 1 burner flange with insulation
- 1 bag containing installation fittings
- 1 bag containing technical documentation (instruction manual, technical data, electrical diagram, exploded view and spare parts list)

DIMENSIONS (mm)

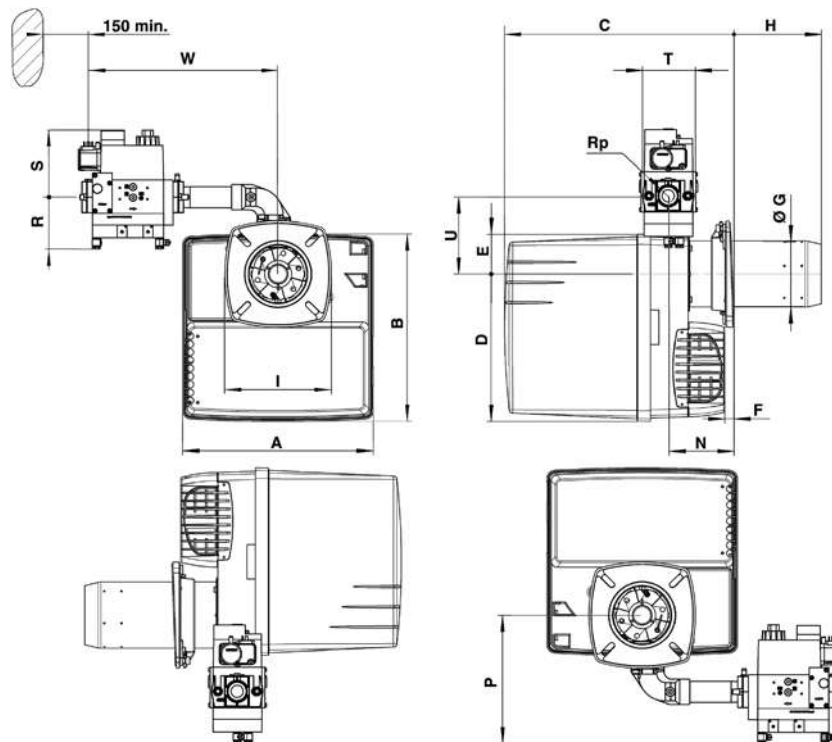

Gas train model	A	B	C		D	E	F min	ØG	H		I	N min	P	Rp	R	S	T	U	W
			KN	KL					KN	KL									
d1"1/4-Rp1"1/4	331	325	398...518	398...638	256	69	15	125	30...150	30...270	185	113	188	1"1/4	80	175	145	133	380
d3/4"-Rp3/4"	331	325	398...518	398...638	256	69	15	125	30...150	30...270	185	113	179	3/4"	70	160	120	133	345

Connecting flange

Øa (mm)	b (mm)	c	d
130-145	160-185	M8	45°

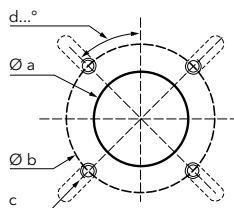

PACKAGING

The burner is delivered in 1 single package containing all components

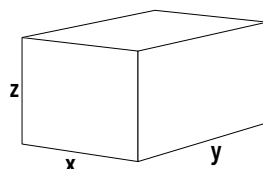

Dimensions (mm)			Gross weight (kg)
X	Y	Z	
400	400	760	26

**VG3.290 V E, VG3.350 V E**

95 ... 350 kW

2 stage progressive/modulating pneumatic + fan speed control (ErP compliant)

- **Fuels:** natural gas (G20/G25,  $H_u = 8,83...10,35 \text{ kWh/m}^3$ );  
LPG (G31,  $H_u = 25,89 \text{ kWh/m}^3$ )
- **Emissions:** compliant with ErP Directive
- **Operation:** two stage progressive or modulating with the installation of a power regulator and dedicated probes (see pag. 180)
- **Protection level:** IP 21



**TECHNICAL DATA**

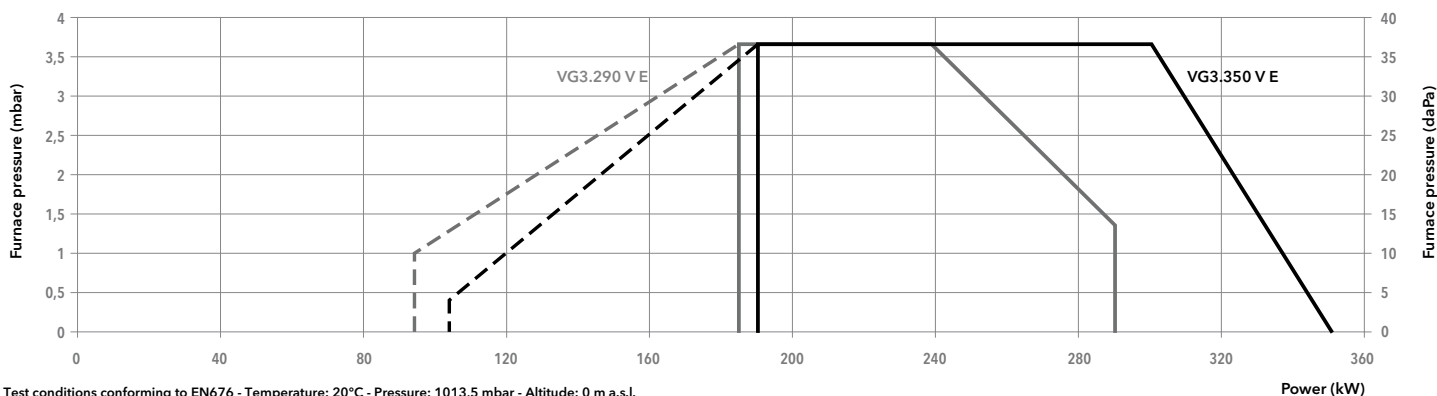

Test conditions conforming to EN676 - Temperature: 20°C - Pressure: 1013,5 mbar - Altitude: 0 m a.s.l.

Model	VG3.290 V E		VG3.350 V E	
Operation range	(95) 185 - 290 kW		(105) 190 - 350 kW	
Gas pressure	20 - 360 mbar		20 - 360 mbar	
Control box / flame detection	TCG5... / ionization		TCG5... / ionization	
Fan motor	230 V - 50 Hz - 250 W		230 V - 50 Hz - 300 W	
Electrical consumption (max/min/stand-by)	465 W / 441 W / 4 W		583 W / 583 W / 4 W	
Acoustic level (LpA)	67 dB(A)		69 dB(A)	
CE certificate	0476 CT 2423		0476 CT 2423	
Head lenght	KN	KL	KN	KL
Complete burner code	MB-VEF 420 d1"1/2-Rp2"	-	3836446	3836447
	MB-VEF 412 d1"1/4-Rp1"1/4"	3836442	3836448	3836449
	MB-VEF 407 d3/4"-Rp1"	3836444	3836445	3836450

**OTHER AVAILABLE VERSIONS**

- TC** Version with tightness control
- Vent** Versions for continuous ventilation and post-ventilation

**SCOPE OF SUPPLY**

The burner is delivered in its package complete with:

- 1 burner head with flange seal and securing screws
- 1 compact gas train with gas filter; the gas filter is built-in for threaded valves (up to 2") and separated for flanged ones (DN65/80/100)
- 1 bag containing installation fittings
- 1 bag containing technical documentation (instruction manual, technical data, electrical diagram, exploded view and spare parts list)

DIMENSIONS (mm)

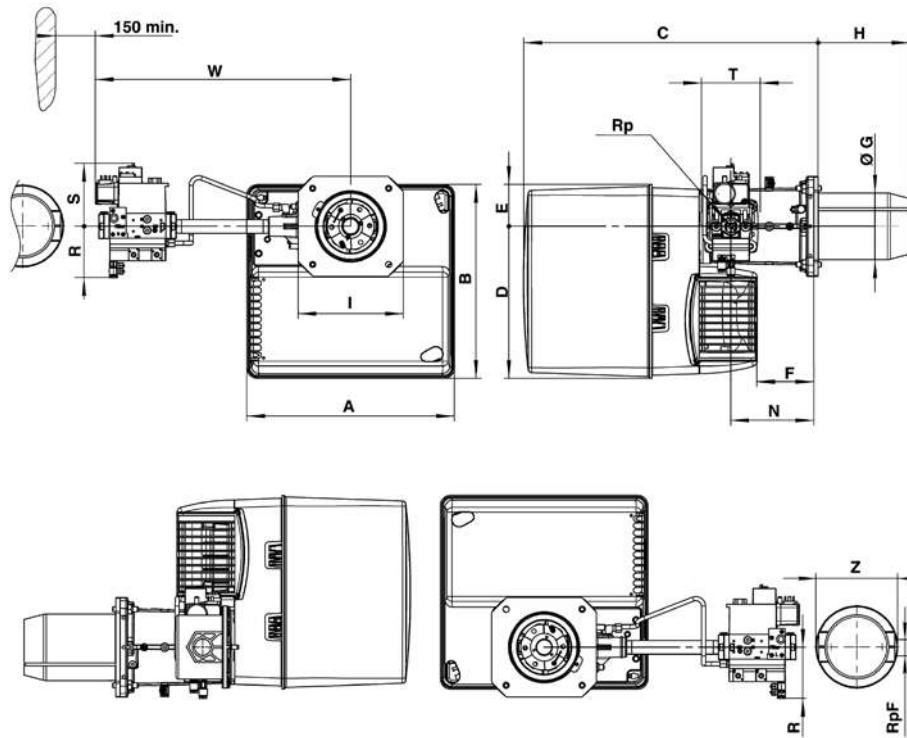

Gas train model	A	B	C	D	E	F	ØG	H		I	N	Rp	R	S	T	W	RpF	Z
								KN	KL									
d1"1/2-Rp2"	406	379	576	297	82	120	130	180	320	195x205	170	2"	100	185	100	603	-	-
d1"1/4-Rp1"1/4	406	379	576	297	82	120	130	180	320	195x205	170	1"1/4	80	175	145	526	-	-
d3/4"-Rp1"	406	379	576	297	82	120	130	180	320	195x205	170	1"	70	160	120	479	1"	160

Connecting flange

Øa (mm)	b (mm)	c	d
155-190	175-220	M10	45°

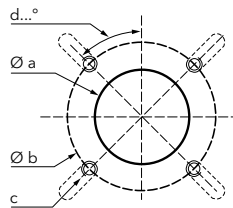

PACKAGING

The burner is delivered on a pallet in 3 packages containing:

- burner housing
- combustion head
- gas train and filter

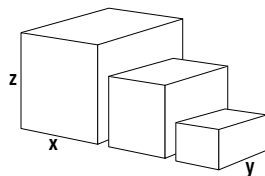

Component		Dimensions (mm)			Gross weight (kg)
		X	Y	Z	
Burner body	VG3.290 V E	440	400	520	21
	VG3.350 V E	440	400	520	22
Combustion head	KN	650	210	260	6
	KL	780	210	260	7
Gas train	d1"1/2-Rp2"	670	550	380	12
	d1"1/4-Rp1"1/4	600	400	240	11
	d3/4"-Rp1"	600	400	240	7

**VG3.290 V E, VG3.350 V E**

95 ... 350 kW

2 stage progressive/modulating pneumatic + fan speed control (ErP compliant)

**PRESSURE LOSS [BURNER HEAD + GAS TRAIN] (mbar)**

**VG3.290 V E**

Burner output (kW)	Natural gas G20 Hi = 10,35 kWh/m <sup>3</sup>		Natural gas G25 Hi = 8,83 kWh/m <sup>3</sup>		LPG G31 Hi = 25,89 kWh/m <sup>3</sup>	
	d3/4"-Rp1"	d1"1/4-Rp1"1/4	d3/4"-Rp1"	d1"1/4-Rp1"1/4	d3/4"-Rp1"	d1"1/4-Rp1"1/4
190	17	9	22	11	11	7
210	18	9	24	12	12	7
230	20	9	27	12	12	7
250	22	10	31	13	13	8
270	25	11	35	15	14	8
290	29	13	40	16	16	9

**Natural gas G20**

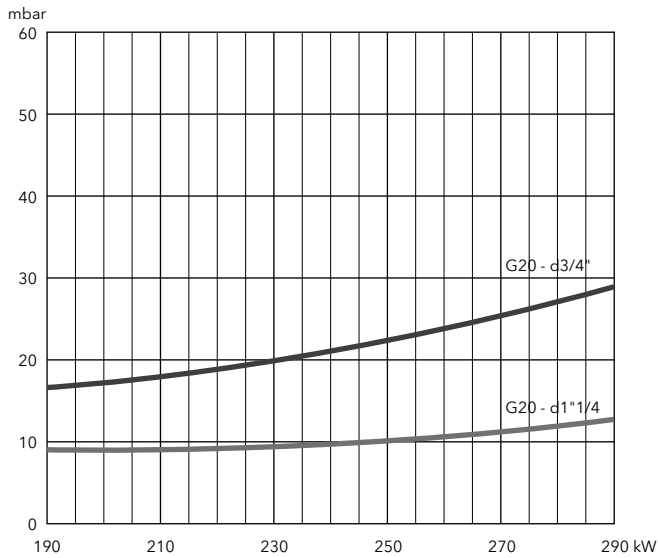

**Natural gas G25**

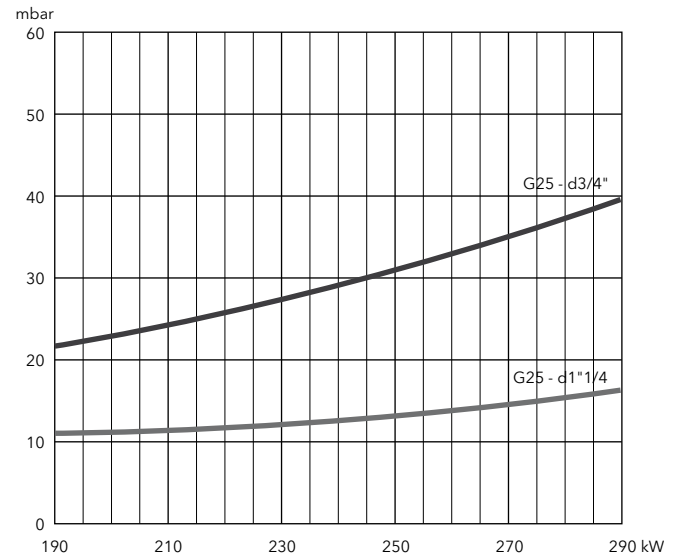

**LPG**

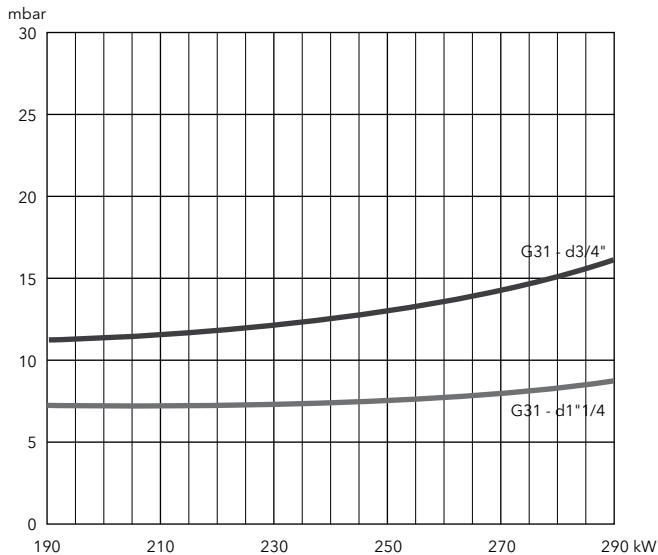





**PRESSURE LOSS [BURNER HEAD + GAS TRAIN] (mbar)**

**VG3.350 V E**

Burner output (kW)	Natural gas G20 Hi = 10,35 kWh/m <sup>3</sup>			Natural gas G25 Hi = 8,83 kWh/m <sup>3</sup>			LPG G31
	d3/4"-Rp1"	d1"1/4-Rp1"1/4	d1"1/2-Rp2"	d3/4"-Rp1"	d1"1/4-Rp1"1/4	d1"1/2-Rp2"	d3/4"-Rp1"
190	13	6	6	19	8	8	8
230	17	7	7	26	11	10	12
270	23	9	8	35	15	13	15
310	29	11	10	44	18	16	18
350	36	14	12	54	22	19	22

**Natural gas G20**

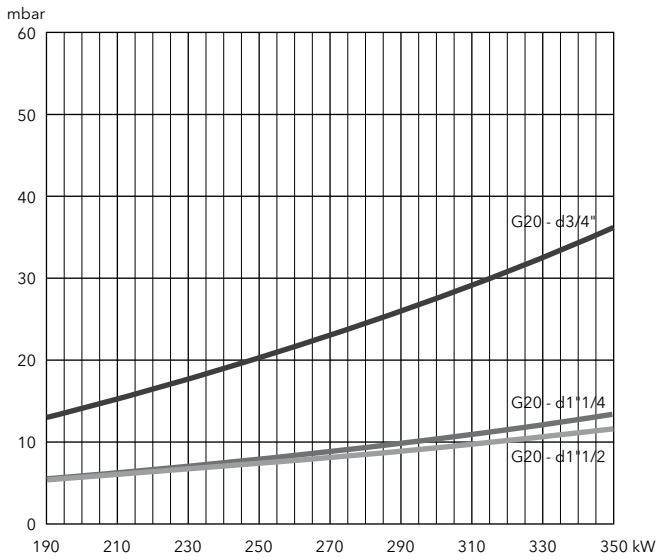

**Natural gas G25**

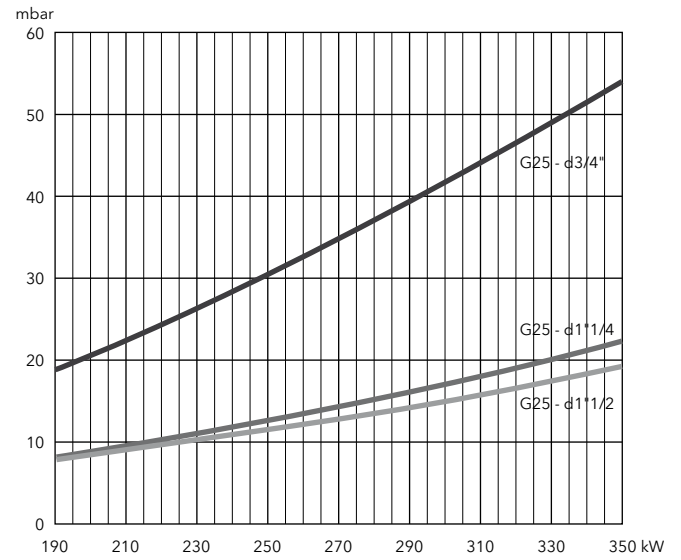

**LPG**

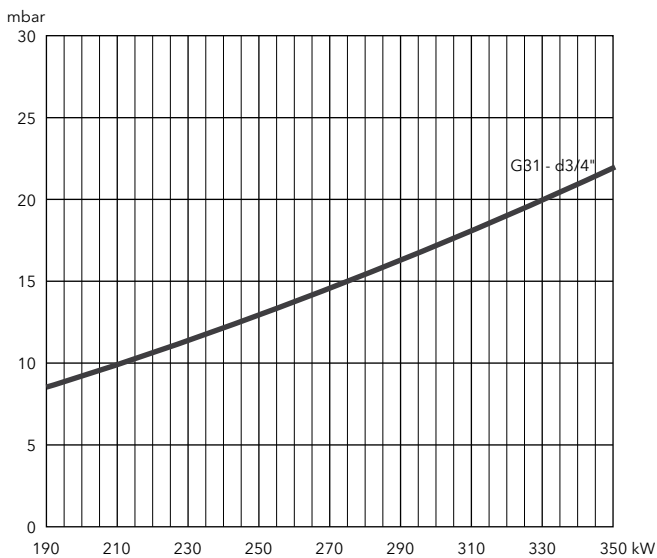

## VG4.440 V E

110 ... 440 kW

2 stage progressive/modulating pneumatic + fan speed control (ErP compliant)

- **Fuels:** natural gas (G20/G25,  $H_u = 8,83...10,35 \text{ kWh/m}^3$ );  
LPG (G31,  $H_u = 25,89 \text{ kWh/m}^3$ )
- **Emissions:** compliant with ErP Directive
- **Operation:** two stage progressive or modulating with the installation of a power regulator and dedicated probes (see pag. 180)
- **Protection level:** IP 21



### TECHNICAL DATA

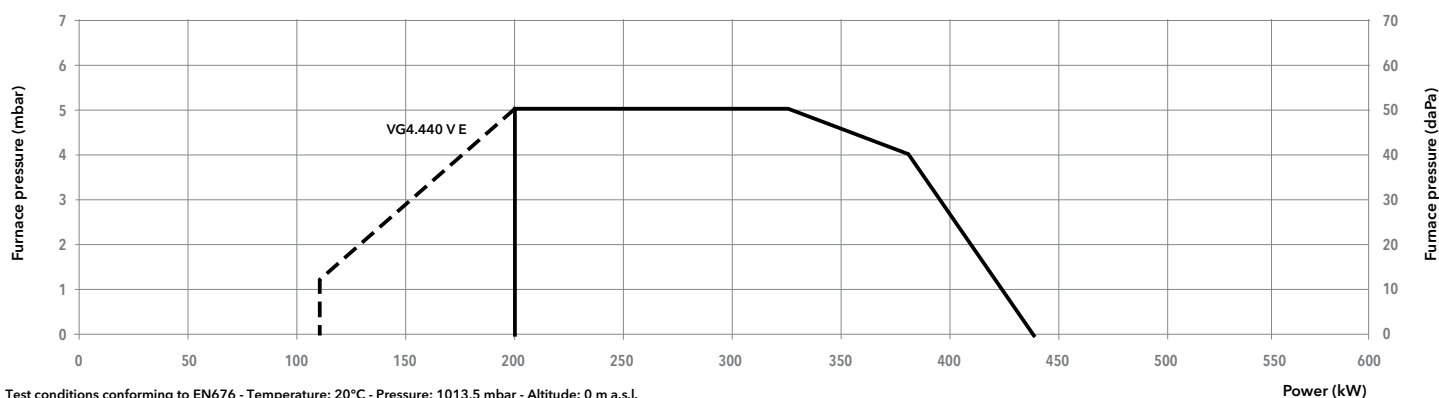

Model		VG4.440 V E	
Operation range		(110) 200 - 440 kW	
Gas pressure		20 - 360 mbar	
Control box / flame detection		TCG5.../ionization	
Fan motor		230 V - 50 Hz - 420 W	
Electrical consumption (max/min/stand-by)		606 W / 569 W / 4 W	
Acoustic level (LpA)		70 dB(A)	
CE certificate		0476 CT 2423	
Head lenght		KN	KL
Complete burner code	MB-VEF 420 d1"1/2-Rp2"	3836452	3836453
	MB-VEF 412 d1"1/4-Rp1"1/4	3836454	3836455
	MB-VEF 407 d3/4"-Rp1"	3836456	3836457

### OTHER AVAILABLE VERSIONS

- TC** Version with tightness control
- V<sub>ent</sub>** Versions for continuous ventilation and post-ventilation

### SCOPE OF SUPPLY

The burner is delivered in its package complete with:

- 1 burner head with flange seal and securing screws
- 1 compact gas train with gas filter; the gas filter is built-in for threaded valves (up to 2") and separated for flanged ones (DN65/80/100)
- 1 bag containing installation fittings
- 1 bag containing technical documentation (instruction manual, technical data, electrical diagram, exploded view and spare parts list)

DIMENSIONS (mm)

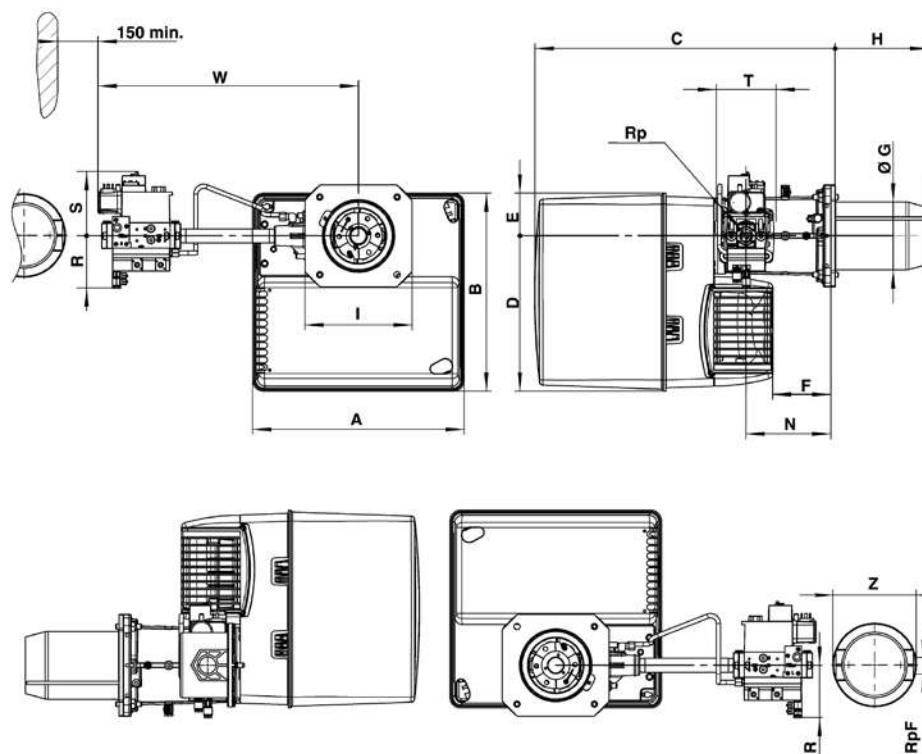

Gas train model	A	B	C	D	E	F	ØG	H		I	N	Rp	R	S	T	W	RpF	Z
								KN	KL									
d1"1/2-Rp2"	465	475	640	377	97	149	157	212	352	245	195	2"	100	185	150	536	-	-
d1"1/4-Rp1"1/4	465	475	640	377	97	149	157	212	352	245	195	1"1/4	80	175	151	489	-	-
d3/4"-Rp1"	465	475	640	377	97	149	157	212	352	245	195	1"	70	160	132	489	1"	160

Connecting flange

Øa (mm)	b (mm)	c	d
190-240	200-270	M10	45°

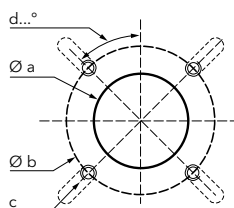

PACKAGING

The burner is delivered on a pallet in 3 packages containing:

- burner housing
- combustion head
- gas train and filter

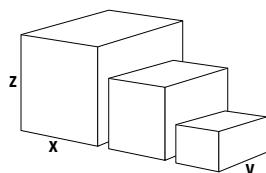

Component		Dimensions (mm)			Gross weight (kg)
		X	Y	Z	
Burner body	VG4.440 V E	490	490	590	28,6
Combustion head	KN	750	260	295	8,9
	KL	895	260	295	10,1
Gas train	d1"1/2-Rp2"	670	550	380	12
	d1"1/4-Rp1"1/4	600	400	240	11
	d3/4"-Rp1"	600	400	240	7

**VG4.440 V E**

110 ... 440 kW

2 stage progressive/modulating pneumatic + fan speed control (ErP compliant)

**PRESSURE LOSS [BURNER HEAD + GAS TRAIN] (mbar)**

**VG4.440 V E**

Burner output (kW)	Natural gas G20 Hi = 10,35 kWh/m <sup>3</sup>			Natural gas G25 Hi = 8,83 kWh/m <sup>3</sup>		
	d3/4"-Rp1"	d1"1/4-Rp1"1/4	d1"1/2-Rp2"	d3/4"-Rp1"	d1"1/4-Rp1"1/4	d1"1/2-Rp2"
240	19	8	7	27	11	10
280	24	9	8	35	13	11
320	30	11	9	42	15	12
360	37	13	11	51	18	15
400	44	15	13	64	22	17
440	51	18	15	78	25	20

**Natural gas G20**

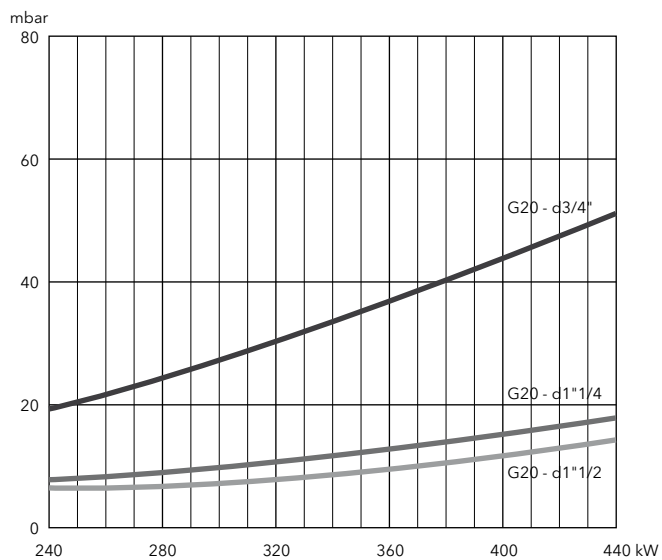

**Natural gas G25**

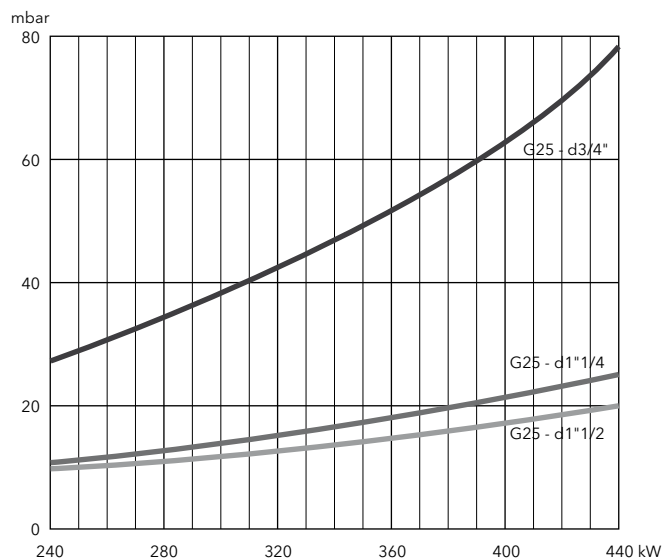



**PRESSURE LOSS [BURNER HEAD + GAS TRAIN] (mbar)**

Burner output (kW)	LPG G31 Hi = 25,89 kWh/m <sup>3</sup>	
	d3/4"-Rp1"	d1"1/4-Rp1"1/4
240	13	8
280	16	9
320	18	10
360	22	11
400	26	13
440	32	16

**LPG**

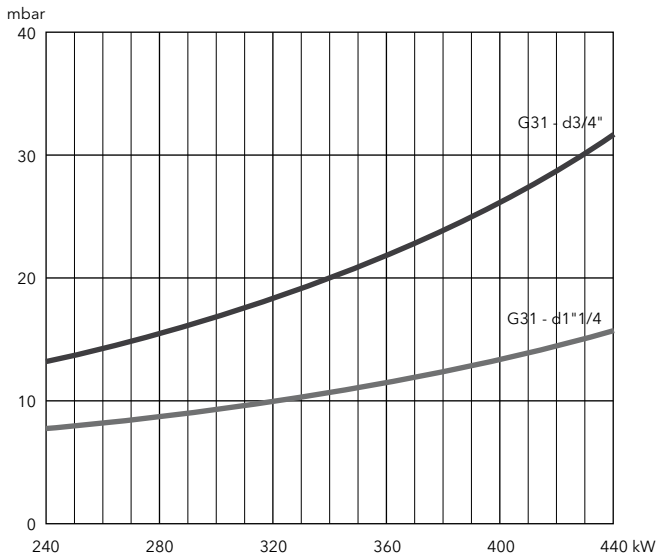

## VG4.610 V

130 ... 610 kW

2 stage progressive/modulating pneumatic + fan speed control (Low NOx class 3)

- **Fuels:** natural gas (G20/G25,  $H_u = 8,83...10,35 \text{ kWh/m}^3$ );  
LPG (G31,  $H_u = 25,89 \text{ kWh/m}^3$ )
- **Emissions:** Low NOx class 3 ( $\leq 80 \text{ mg/kWh}$ ) according to EN676
- **Operation:** two stage progressive or modulating with the installation of a power regulator and dedicated probes (see pag. 180)
- **Protection level:** IP 41



### TECHNICAL DATA

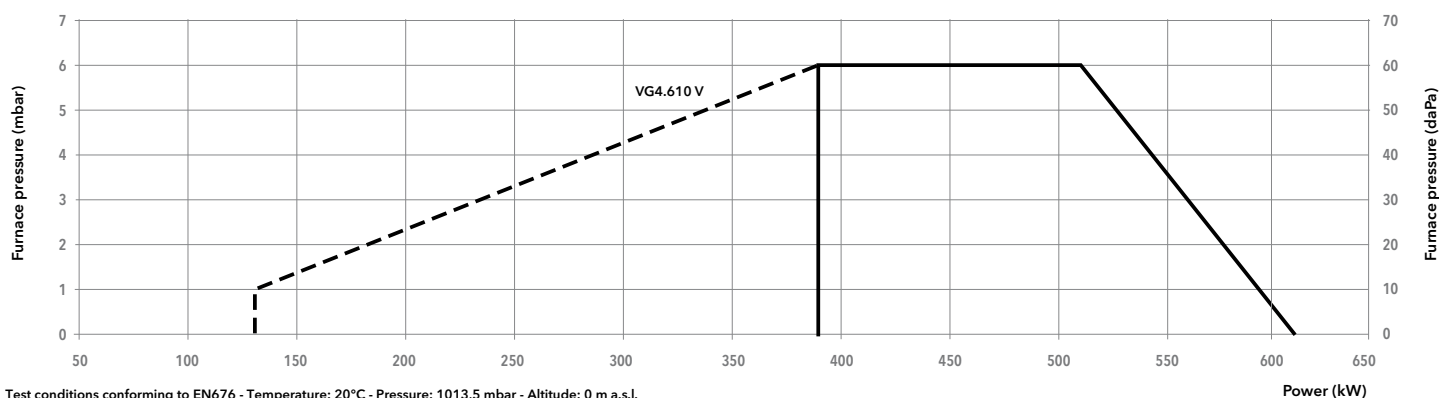

Model		VG4.610 V	
Operation range		(130) 390 - 610 kW	
Gas pressure		20 - 300 mbar	
Control box / flame detection		TCG5.../ionization	
Fan motor		230 V - 50 Hz - 750 W	
Electrical consumption		68 + 720 W	
Acoustic level (LpA)		71 dB(A)	
CE certificate		1312 CL 5412	
Head lenght		KN	KL
Complete burner code	MB-VEF 420 d1"1/2-Rp2"	3833875	3833876
	MB-VEF 412 d1"1/4-Rp1"1/4	3833879	3833880
	MB-VEF 407 d3/4"-Rp1"	3833883	3833884

### OTHER AVAILABLE VERSIONS

- TC** Version with tightness control
- V<sub>ent</sub>** Versions for continuous ventilation and post-ventilation

### SCOPE OF SUPPLY

The burner is delivered in its package complete with:

- 1 burner head with flange seal and securing screws
- 1 compact gas train with gas filter; the gas filter is built-in for threaded valves (up to 2") and separated for flanged ones (DN65/80/100)
- 1 bag containing installation fittings
- 1 bag containing technical documentation (instruction manual, technical data, electrical diagram, exploded view and spare parts list)

DIMENSIONS (mm)

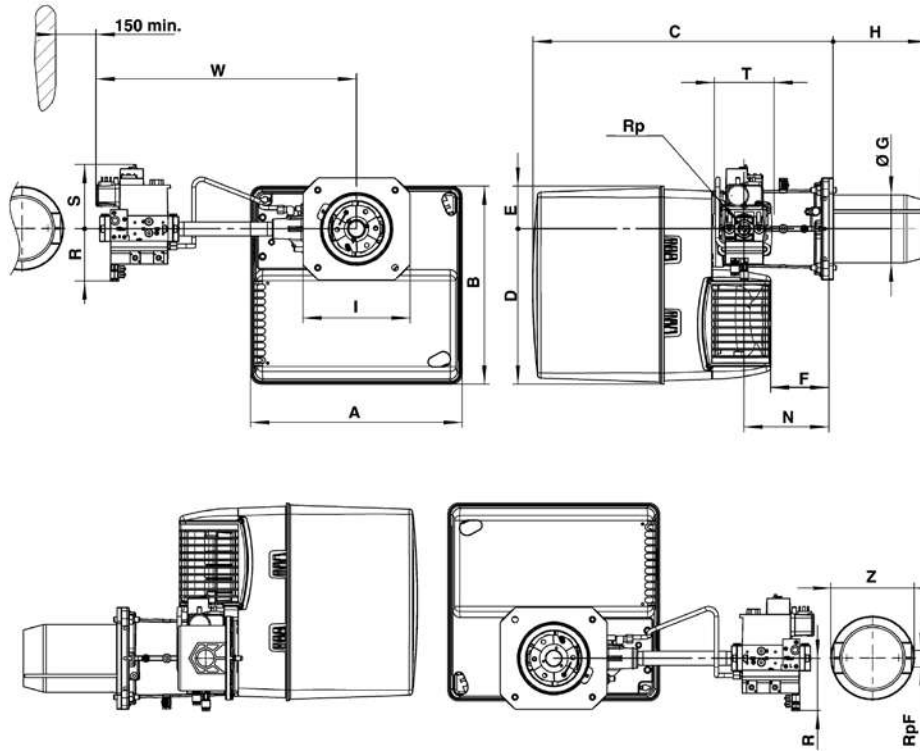

Gas train model	A	B	C	D	E	F	ØG	H		I	N	Rp	R	S	T	W	RpF	Z
								KN	KL									
d1"1/2-Rp2"	465	475	640	377	97	149	150	220	360	245	195	2"	100	185	100	613	-	-
d1"1/4-Rp1"1/4	465	475	640	377	97	149	150	220	360	245	195	1"1/4	80	175	145	536	-	-
d3/4"-Rp1"	465	475	640	377	97	149	150	220	360	245	195	1"	70	160	120	489	1"	160

Connecting flange

Øa (mm)	b (mm)	c	d
180-240	200-270	M10	45°

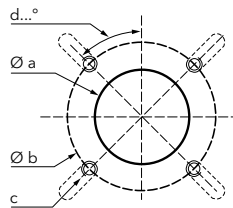

PACKAGING

The burner is delivered on a pallet in 3 packages containing:

- burner housing
- combustion head
- gas train and filter

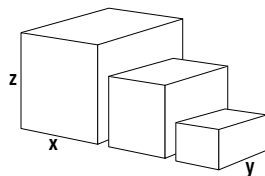

Component		Dimensions (mm)			Gross weight (kg)
		X	Y	Z	
Burner body	VG4.610 V	490	490	590	28,6
Combustion head	KN	750	260	295	8,9
	KL	895	260	295	10,1
Gas train	d1"1/2-Rp2"	670	550	380	12
	d1"1/4-Rp1"1/4	600	400	240	11
	d3/4"-Rp1"	600	400	240	7

**VG4.610 V**

130 ... 610 kW

2 stage progressive/modulating pneumatic + fan speed control (Low NOx class 3)

**PRESSURE LOSS [BURNER HEAD + GAS TRAIN] (mbar)**

**VG4.610 V**

Burner output (kW)	Natural gas G20 Hi = 10,35 kWh/m <sup>3</sup>			Natural gas G25 Hi = 8,83 kWh/m <sup>3</sup>		
	d3/4"-Rp1"	d1"1/4-Rp1"1/4	d1"1/2-Rp2"	d3/4"-Rp1"	d1"1/4-Rp1"1/4	d1"1/2-Rp2"
350	53	9	6	78	13	7
400	70	12	8	102	17	9
450	88	16	10	129	21	11
500	109	19	12	159	26	14
550	132	23	15	192	32	17
610	162	29	18	236	39	20

**Natural gas G20**

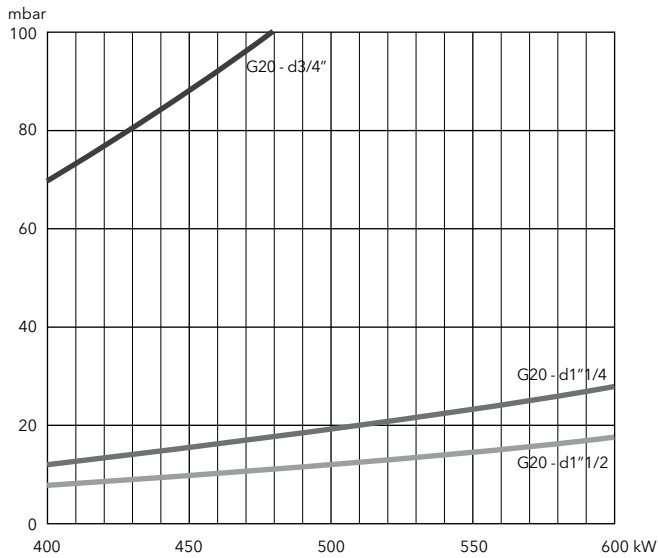

**Natural gas G25**

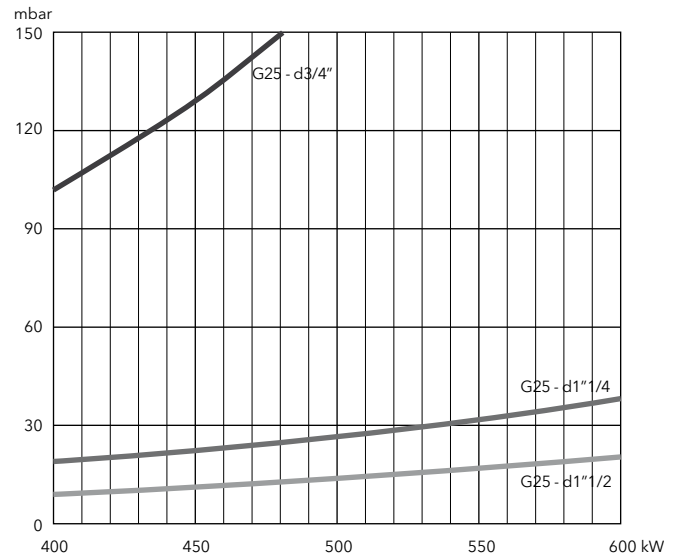



Variatron

MDE2

RTC

LOW  
NO<sub>x</sub>  
CLASS 3

## PRESSURE LOSS [BURNER HEAD + GAS TRAIN] (mbar)

Burner output (kW)	LPG G31 Hi = 25,89 kWh/m <sup>3</sup>	
	d3/4"-Rp1"	d1"1/4-Rp1"1/4
240	25	8
280	32	10
320	41	13
360	50	16
400	61	20
440	75	24

## LPG

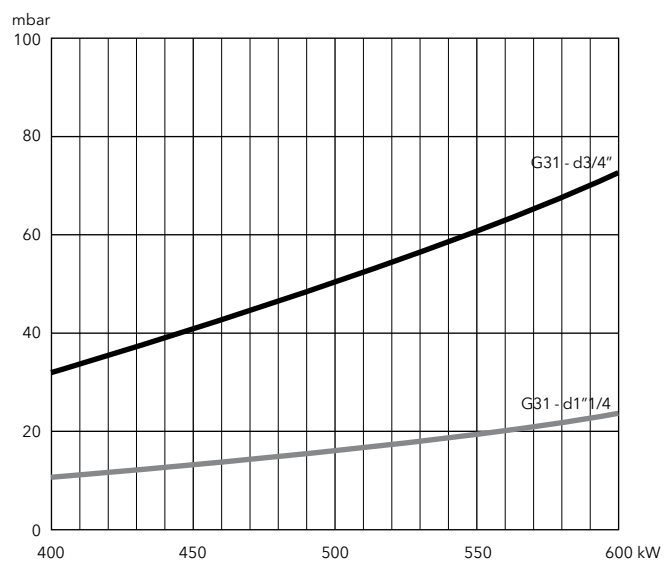

**VG2.120 M E, VG2.160 M E, VG2.205 M E**

40 ... 205 kW

2 stage progressive/modulating electronic (ErP compliant)

- **Fuels:** natural gas (G20/G25,  $H_u = 8,83...10,35 \text{ kWh/m}^3$ );  
LPG (G31,  $H_u = 25,89 \text{ kWh/m}^3$ )
- **Emissions:** compliant with ErP Directive
- **Operation:** two stage progressive or modulating with the installation of a power regulator and dedicated probes (see pag. 180);  
integrated tightness control
- **Protection level:** IP 21



**TECHNICAL DATA**

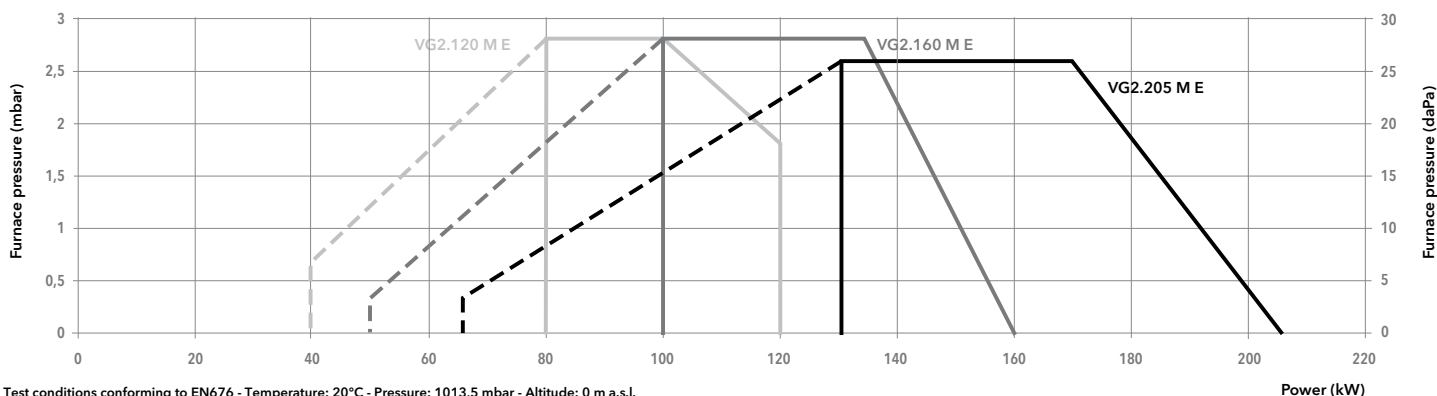

Model	VG2.120 M E /TC		VG2.160 M E /TC		VG2.205 M E /TC		
Operation range	(40) 80 - 120 kW		(50) 100 - 160 kW		(65) 130 - 205 kW		
Gas pressure	20 - 360 mbar		20 - 360 mbar		20 - 360 mbar		
Control box / flame detection	BT3... / ionization		BT3... / ionization		BT3... / ionization		
Fan motor	230 V - 50 Hz - 100 W		230 V - 50 Hz - 100 W		230 V - 50 Hz - 130 W		
Electrical consumption (max/min/stand-by)	239 W / 358 W / 4 W		285 W / 293 W / 4 W		302 W / 267 W / 4 W		
Acoustic level (LpA)	62 dB(A)		64 dB(A)		65 dB(A)		
CE certificate	0476 CT 2423		0476 CT 2423		0476 CT 2423		
Head lenght	KN	KL	KN	KL	KN	KL	
Complete burner code	MBC300 d3/4"-Rp3/4"/TC	<b>3836480</b>	<b>3836481</b>	<b>3836482</b>	<b>3836483</b>	<b>3836484</b>	<b>3836485</b>

**OTHER AVAILABLE VERSIONS**

Versions for continuous ventilation and post-ventilation

**SCOPE OF SUPPLY**

The burner is delivered in its package complete with:

- 1 gas connection flange
- 1 compact gas train with gas filter; the gas filter is built-in for threaded valves (up to 2") and separated for flanged ones (DN65/80/100)
- 1 burner flange with insulation
- 1 bag containing installation fittings
- 1 bag containing technical documentation (instruction manual, technical data, electrical diagram, exploded view and spare parts list)



**DIMENSIONS (mm)**

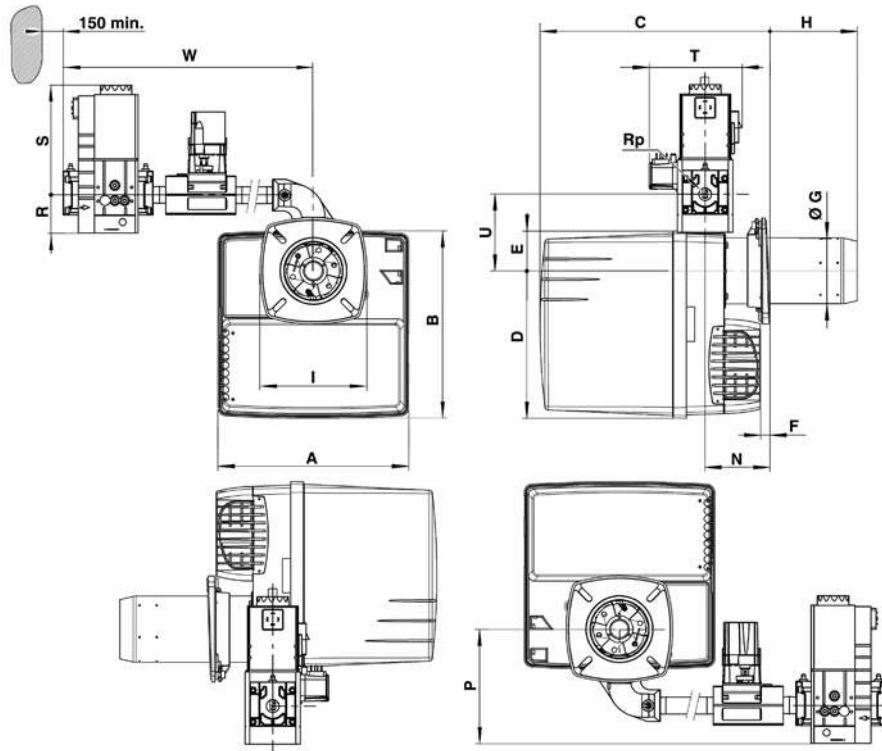

	A	B	C		D	E	F min	ØG	H		I	N min	P	Rp	R	S	T	U	W
			KN	KL					KN	KL									
VG2.120/160	331	325	398...518	398...638	256	69	15	115	30...150	30...270	185	113	193	3/4"	60	173	146	133	455
VG2.205	331	325	398...518	398...638	256	69	15	125	30...150	30...270	185	113	193	3/4"	60	173	146	133	455

**Connecting flange**

	Øa (mm)	b (mm)	c	d
VG2.120/160	120-135	150-185	M8	45°
VG2.205	130-145	160-185	M8	45°

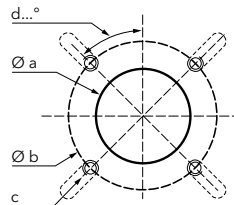

**PACKAGING**

The burner is delivered in 2 packages containing:  
 • burner housing and combustion head;  
 • gas train and filter.

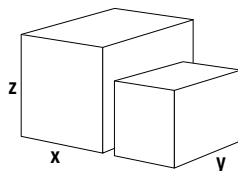

Component	Dimensions (mm)			Gross weight (kg)	
	X	Y	Z		
Burner body	VG2.120 M E	400	440	520	25
	VG2.160 M E	400	440	520	25
	VG2.205 M E	400	440	520	25
Gas train	d3/4"-Rp3/4"/TC	540	670	380	12

**VG3.290 M E, VG3.350 M E**

95 ... 350 kW  
2 stage progressive/modulating electronic (ErP compliant)

- **Fuels:** natural gas (G20/G25,  $H_u = 8,83...10,35 \text{ kWh/m}^3$ );  
LPG (G31,  $H_u = 25,89 \text{ kWh/m}^3$ )
- **Emissions:** compliant with ErP Directive
- **Operation:** two stage progressive or modulating with the installation of a power regulator and dedicated probes (see pag. 180);  
integrated tightness control
- **Protection level:** IP 21



**TECHNICAL DATA**

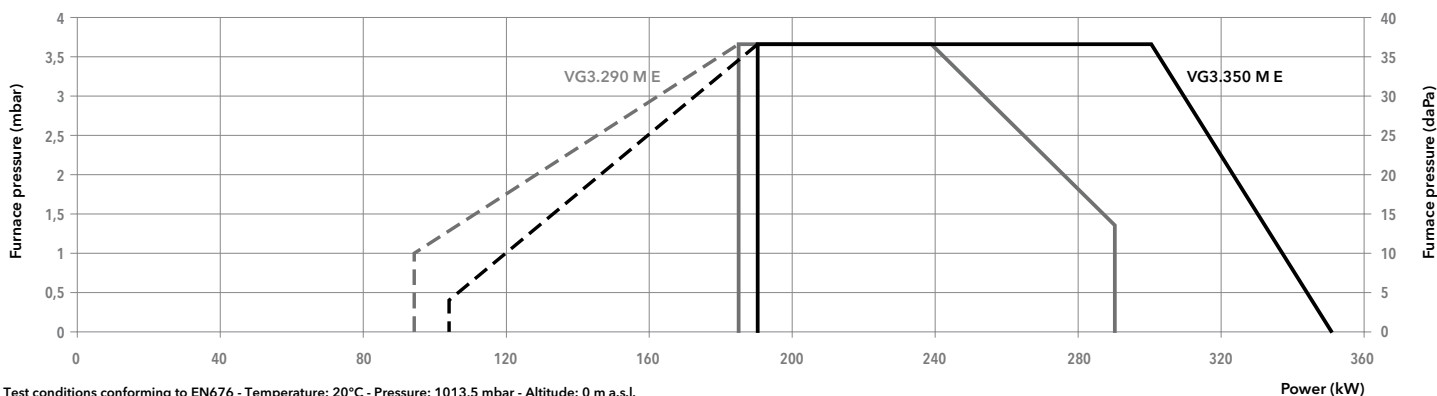

Test conditions conforming to EN676 - Temperature: 20°C - Pressure: 1013,5 mbar - Altitude: 0 m a.s.l.

Model	VG3.290 M E /TC		VG3.350 M E /TC	
Operation range	(95) 185 - 290 kW		(105) 190 - 350 kW	
Gas pressure	20 - 360 mbar		20 - 360 mbar	
Control box / flame detection	BT3... / ionization		BT3... / ionization	
Fan motor	230 V - 50 Hz - 250 W		230 V - 50 Hz - 300 W	
Electrical consumption (max/min/stand-by)	465 W / 441 W / 4 W		583 W / 583 W / 4 W	
Acoustic level (LpA)	67 dB(A)		69 dB(A)	
CE certificate	0476 CT 2423		0476 CT 2423	
Head lenght	KN	KL	KN	KL
Complete burner code	MBC700 d1"1/2-Rp1"1/2/TC MBC300 d3/4"-Rp1"1/4/TC	- 3836486	- 3836487	3836488 3836490
				3836489 3836491

**OTHER AVAILABLE VERSIONS**

Versions for continuous ventilation and post-ventilation

**SCOPE OF SUPPLY**

The burner is delivered in its package complete with:

- 1 burner head with flange seal and securing screws
- 1 compact gas train with gas filter; the gas filter is built-in for threaded valves (up to 2") and separated for flanged ones (DN65/80/100)
- 1 bag containing installation fittings
- 1 bag containing technical documentation (instruction manual, technical data, electrical diagram, exploded view and spare parts list)

DIMENSIONS (mm)

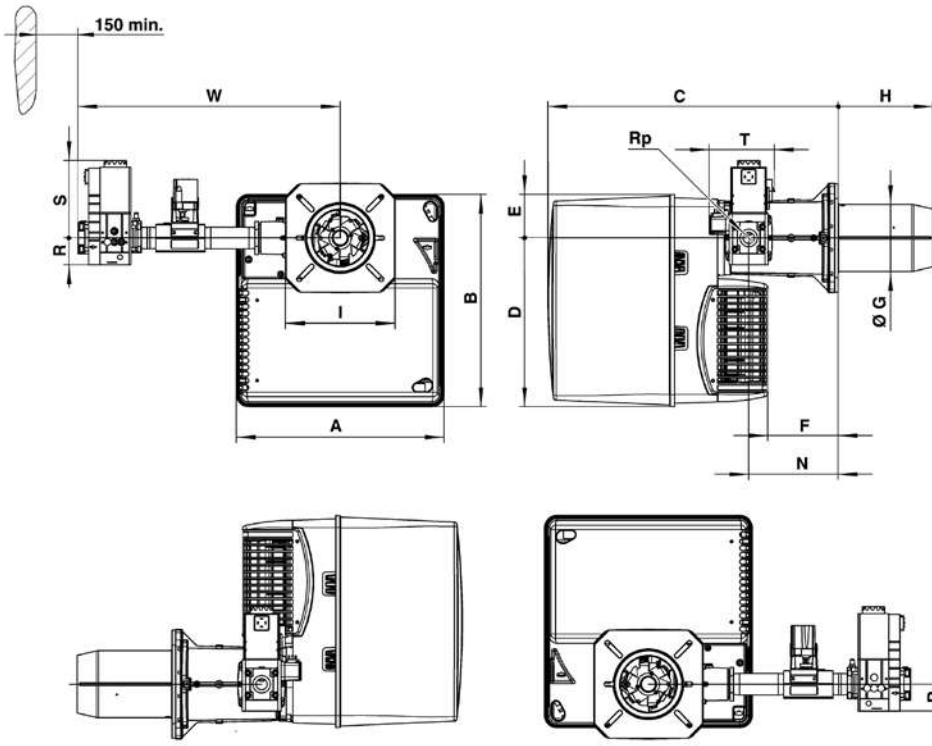

Gas train model	A	B	C	D	E	F	ØG	H		I	N	Rp	R	S	T	W
								KN	KL							
d1"1/2-Rp1"1/2/TC	406	379	576	297	82	120	130	180	320	195x205	170	1"1/2	80	185	160	638
d3/4"-Rp1"1/4/TC	406	379	576	297	82	120	130	180	320	195x205	170	1"1/4	60	173	146	577

Connecting flange

Øa (mm)	b (mm)	c	d
155-190	175-220	M10	45°

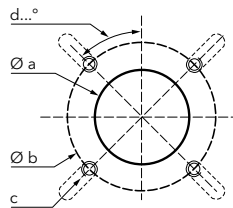

PACKAGING

The burner is delivered on a pallet in 3 packages containing:

- burner housing
- combustion head
- gas train and filter

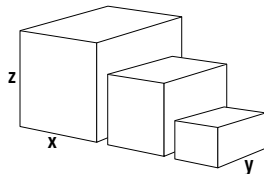

Component		Dimensions (mm)			Gross weight (kg)
		X	Y	Z	
Burner body	VG3.290 M E	440	400	520	21
	VG3.350 M E	440	400	520	22
Combustion head	KN	650	210	260	6
	KL	780	210	260	7
Gas train	d1"1/2-Rp1"1/2/TC	670	540	380	12
	d3/4"-Rp1"1/4/TC	670	540	380	12

**VG3.290 M E, VG3.350 M E**

95 ... 350 kW

2 stage progressive/modulating electronic (ErP compliant)

**PRESSURE LOSS [BURNER HEAD + GAS TRAIN] (mbar)**

**VG3.290 M E**

Burner output (kW)	Natural gas G20 Hi = 10,35 kWh/m <sup>3</sup>	Natural gas G25 Hi = 8,83 kWh/m <sup>3</sup>	LPG G31 Hi = 25,89 kWh/m <sup>3</sup>
	d3/4"-Rp1"1/4	d3/4"-Rp1"1/4	d3/4"-Rp1"1/4
190	12	14	10
210	12	15	10
230	13	16	10
250	14	18	10
270	16	20	11
290	18	23	12

**Natural gas G20**

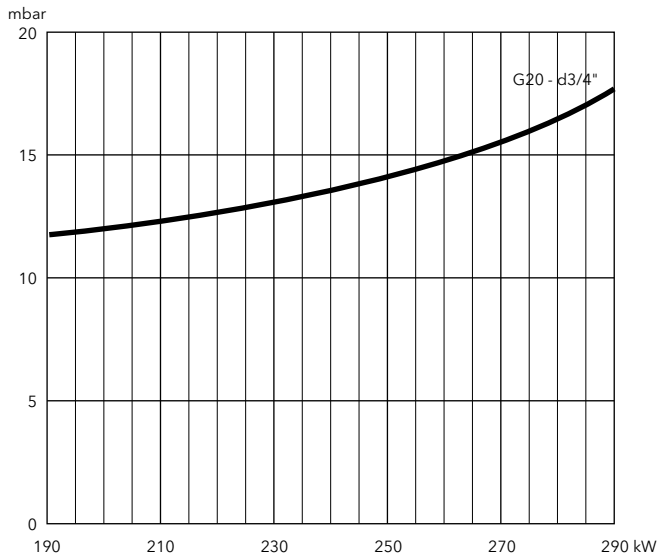

**Natural gas G25**

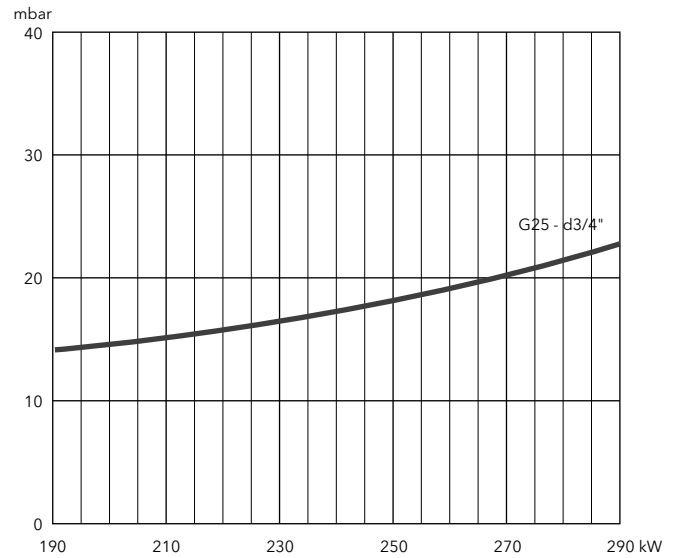

**LPG**

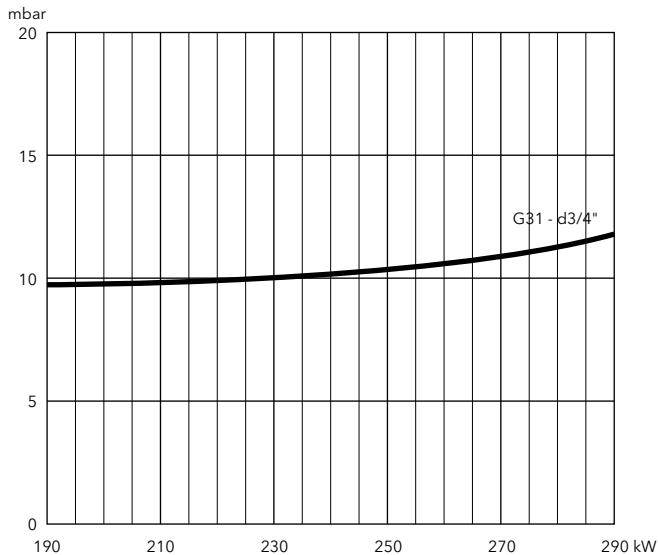



**PRESSURE LOSS [BURNER HEAD + GAS TRAIN] (mbar)**

**VG3.350 M E**

Burner output (kW)	Natural gas G20 Hi = 10,35 kWh/m <sup>3</sup>		Natural gas G25 Hi = 8,83 kWh/m <sup>3</sup>		LPG G31 Hi = 25,89 kWh/m <sup>3</sup>	
	d3/4"-Rp1"1/4	d1"1/2-Rp1"1/2	d3/4"-Rp1"1/4	d1"1/2-Rp1"1/2	d3/4"-Rp1"1/4	d1"1/2-Rp1"1/2
190	9	5	11	5	7	6
230	10	6	15	6	8	7
270	12	7	19	7	11	8
310	15	9	25	9	13	10
350	20	11	32	12	16	12

**Natural gas G20**

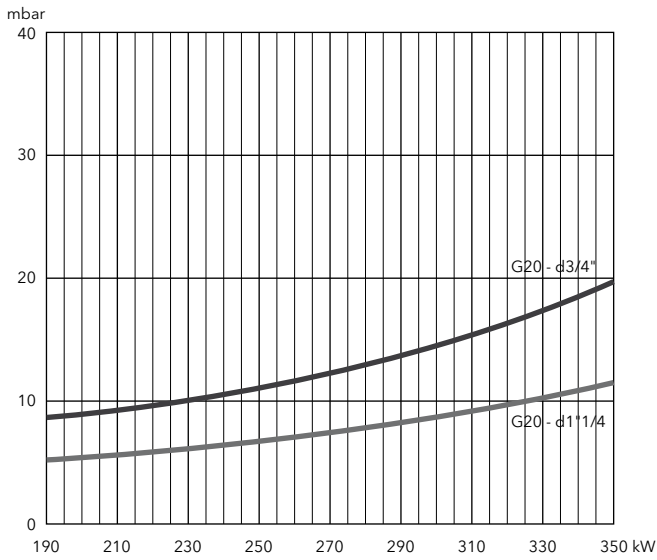

**Natural gas G25**

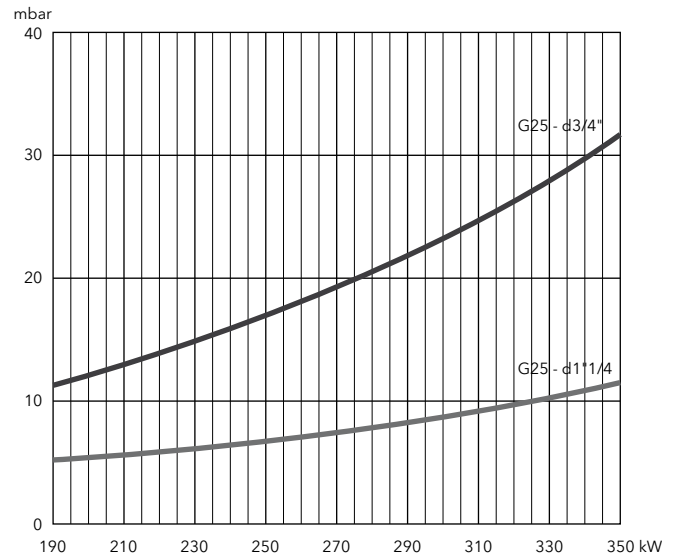

**LPG**

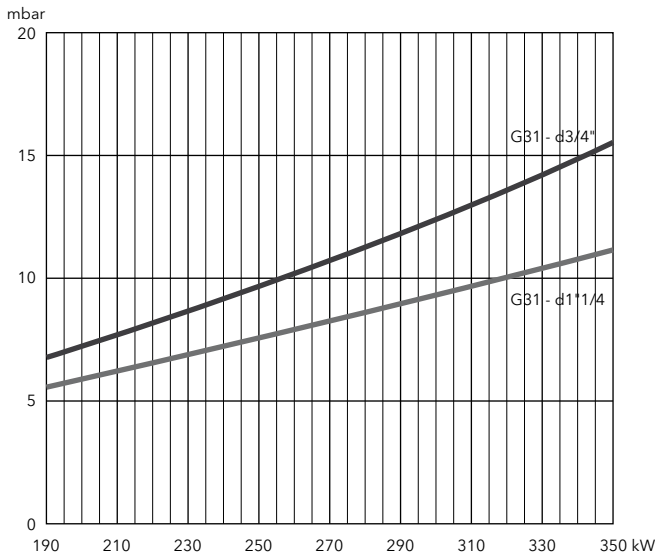

## VG4.440 M E

110 ... 440 kW

2 stage progressive/modulating electronic (ErP compliant)

- **Fuels:** natural gas (G20/G25,  $H_u = 8,83...10,35 \text{ kWh/m}^3$ );  
LPG (G31,  $H_u = 25,89 \text{ kWh/m}^3$ )
- **Emissions:** compliant with ErP Directive
- **Operation:** two stage progressive or modulating with the installation of a power regulator and dedicated probes (see pag. 180);  
integrated tightness control
- **Protection level:** IP 21



### TECHNICAL DATA

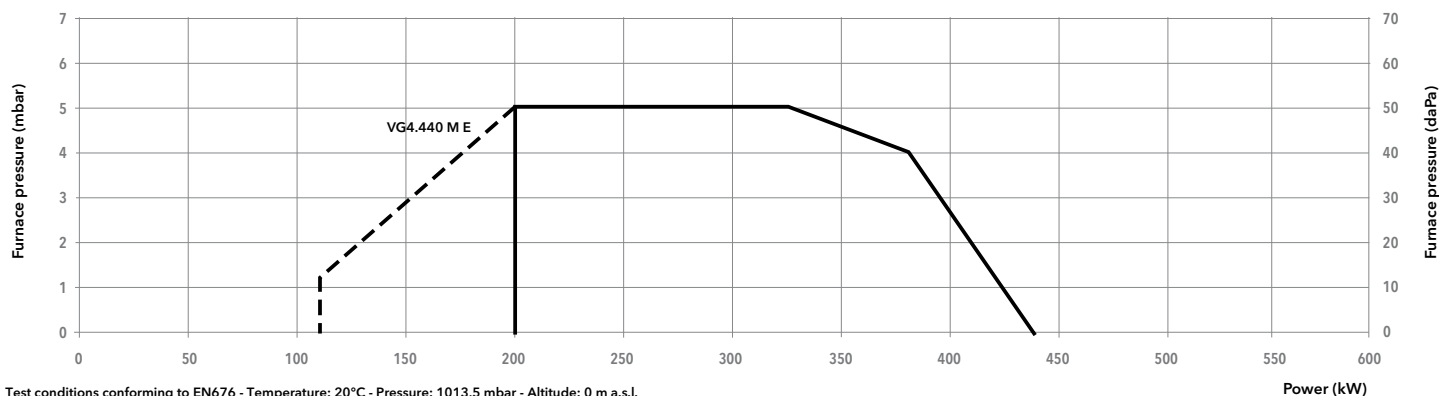

<b>Model</b>	<b>VG4.440 M E /TC</b>		
<b>Operation range</b>	(110) 200 - 440		
<b>Gas pressure</b>	20 - 360 mbar		
<b>Control box / flame detection</b>	BT3... / ionization		
<b>Fan motor</b>	230 V - 50 Hz - 420 W		
<b>Electrical consumption</b>	606 W / 569 W / 4 W		
<b>Acoustic level (LpA)</b>	70 dB(A)		
<b>CE certificate</b>	0476 CT 2423		
<b>Head lenght</b>	KN		KL
<b>Complete burner code</b>	MBC700 d1"1/2-Rp1"1/2/TC	<b>3836492</b>	<b>3836494</b>
	MBC300 d3/4"-Rp1"1/4/TC	<b>3836493</b>	<b>3836495</b>

### OTHER AVAILABLE VERSIONS

Versions for continuous ventilation and post-ventilation

### SCOPE OF SUPPLY

The burner is delivered in its package complete with:

- 1 burner head with flange seal and securing screws
- 1 compact gas train with gas filter; the gas filter is built-in for threaded valves (up to 2") and separated for flanged ones (DN65/80/100)
- 1 bag containing installation fittings
- 1 bag containing technical documentation (instruction manual, technical data, electrical diagram, exploded view and spare parts list)





**DIMENSIONS (mm)**

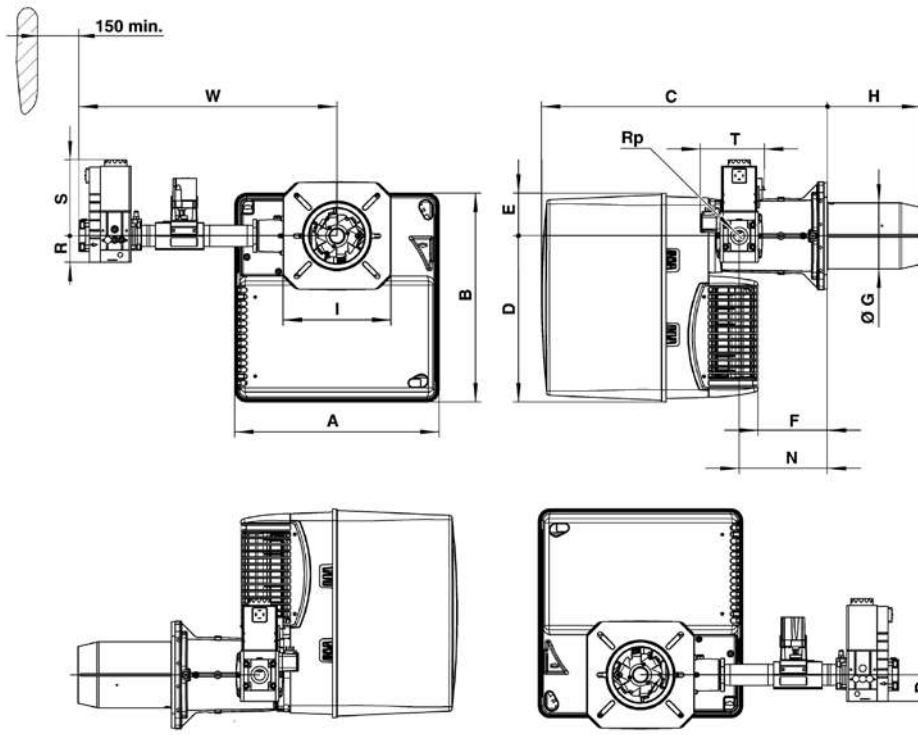

Gas train model	A	B	C	D	E	F	ØG	H		I	N	Rp	R	S	T	W
								KN	KL							
d1"1/2-Rp1"1/2/TC	465	475	640	377	97	149	157	212	352	245	195	1"1/2	80	185	160	649
d3/4"-Rp1"1/4/TC	465	475	640	377	97	149	157	212	352	245	195	1"1/4	60	173	146	587

**Connecting flange**

Øa (mm)	b (mm)	c	d
190-240	200-270	M10	45°

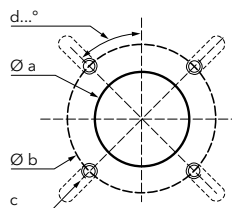

**PACKAGING**

The burner is delivered on a pallet in 3 packages containing:

- burner housing
- combustion head
- gas train and filter

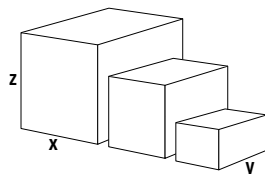

Component	Component	Dimensions (mm)			Gross weight (kg)
		X	Y	Z	
Burner body	VG4.440 M E	490	490	590	28,6
	KN	750	260	295	8,9
Combustion head	KL	895	260	295	10,1
	d1"1/2-Rp1"1/2/TC	670	540	380	12
Gas train	d3/4"-Rp1"1/4/TC	670	540	380	12

**VG4.440 M E**

110 ... 440 kW

2 stage progressive/modulating electronic (ErP compliant)

**PRESSURE LOSS [BURNER HEAD + GAS TRAIN] (mbar)**

**VG4.440 M E**

Burner output (kW)	Natural gas G20 Hi = 10,35 kWh/m <sup>3</sup>		Natural gas G25 Hi = 8,83 kWh/m <sup>3</sup>	
	d3/4"-Rp1"1/4	d1"1/2-Rp1"1/2	d3/4"-Rp1"1/4	d1"1/2-Rp1"1/2
240	11	7	15	9
280	13	8	18	10
320	16	9	22	12
360	19	10	28	14
400	23	12	34	17
440	28	14	41	20

**Natural gas G20**

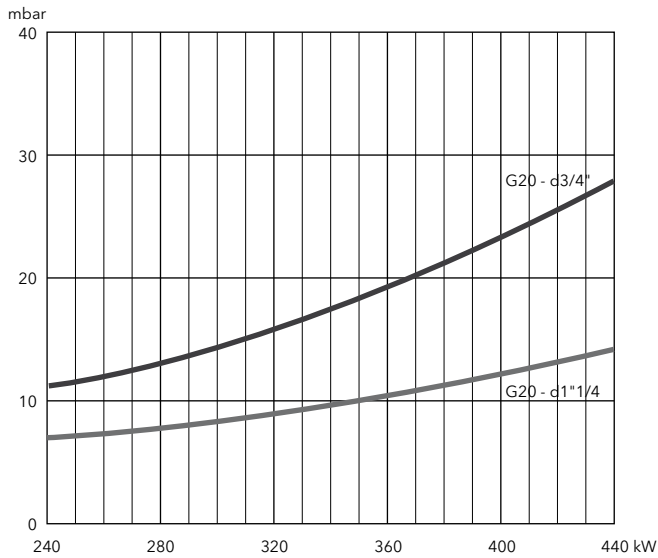

**Natural gas G25**

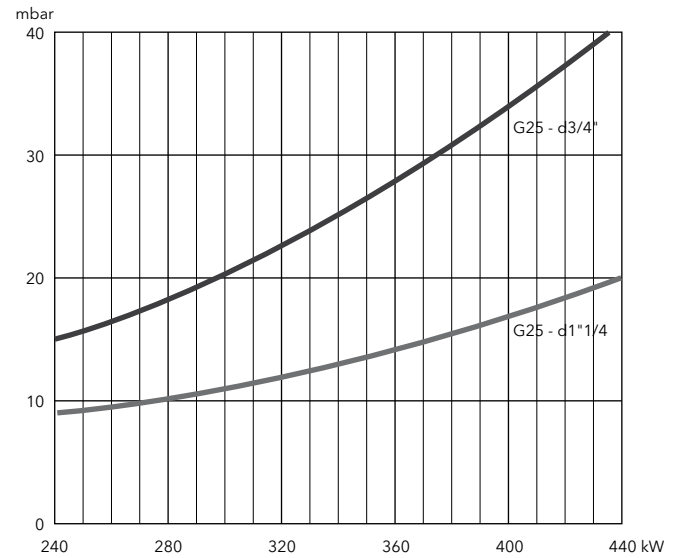



**PRESSURE LOSS [BURNER HEAD + GAS TRAIN] (mbar)**

Burner output (kW)	LPG G31 Hi = 25,89 kWh/m <sup>3</sup>	
	d3/4"-Rp1"1/4	d1"1/2-Rp1"1/2
240	10	8
280	11	9
320	13	9
360	15	11
400	17	13
440	20	15

**LPG**

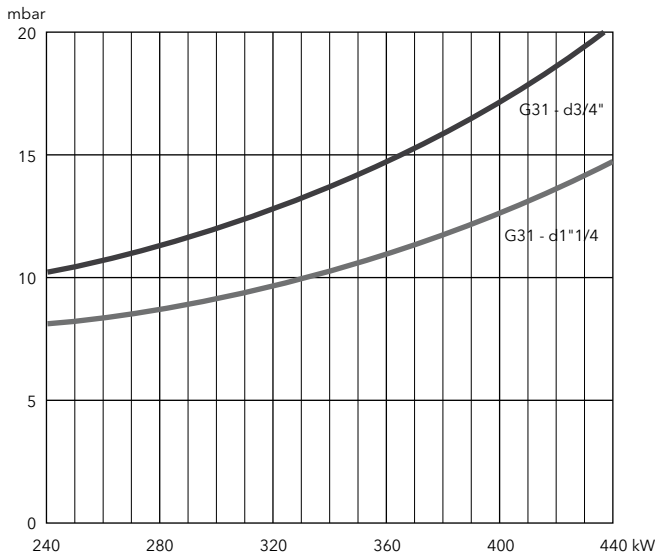

**VG4.610 M**

90 ... 610 kW

2 stage progressive/modulating electronic (Low NOx class 3)

- **Fuels:** natural gas (G20/G25,  $H_u = 8,83...10,35 \text{ kWh/m}^3$ );  
LPG (G31,  $H_u = 25,89 \text{ kWh/m}^3$ )
- **Emissions:** Low NOx class 3 ( $\leq 80 \text{ mg/kWh}$ ) according to EN676
- **Operation:** two stage progressive or modulating with the installation of a power regulator and dedicated probes (see pag. 180);  
integrated tightness control
- **Protection level:** IP 41

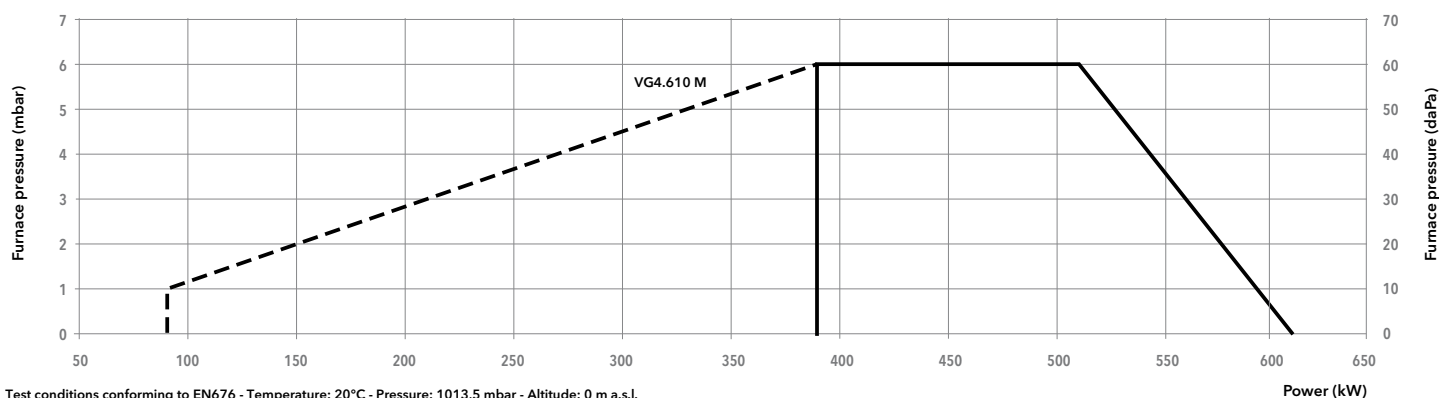
**TECHNICAL DATA**

<b>Model</b>	<b>VG4.610 M /TC</b>		
<b>Operation range</b>	(90) 390 - 610 kW		
<b>Gas pressure</b>	20 - 300 mbar		
<b>Control box / flame detection</b>	BT3... / ionization		
<b>Fan motor</b>	230 V - 50 Hz - 750 W		
<b>Electrical consumption</b>	760 W		
<b>Acoustic level (LpA)</b>	71 dB(A)		
<b>CE certificate</b>	0085 CN 0192		
<b>Head lenght</b>	KN		KL
<b>Complete burner code</b>	MBC700 d1"1/2-Rp1"1/2/TC	<b>3833786</b>	<b>3833787</b>
	MBC300 d3/4"-Rp1"1/4/TC	<b>3833784</b>	<b>3833785</b>

**OTHER AVAILABLE VERSIONS**

 Versions for continuous ventilation and post-ventilation

**SCOPE OF SUPPLY**

The burner is delivered in its package complete with:

- 1 burner head with flange seal and securing screws
- 1 compact gas train with gas filter; the gas filter is built-in for threaded valves (up to 2") and separated for flanged ones (DN65/80/100)
- 1 bag containing installation fittings
- 1 bag containing technical documentation (instruction manual, technical data, electrical diagram, exploded view and spare parts list)

DIMENSIONS (mm)

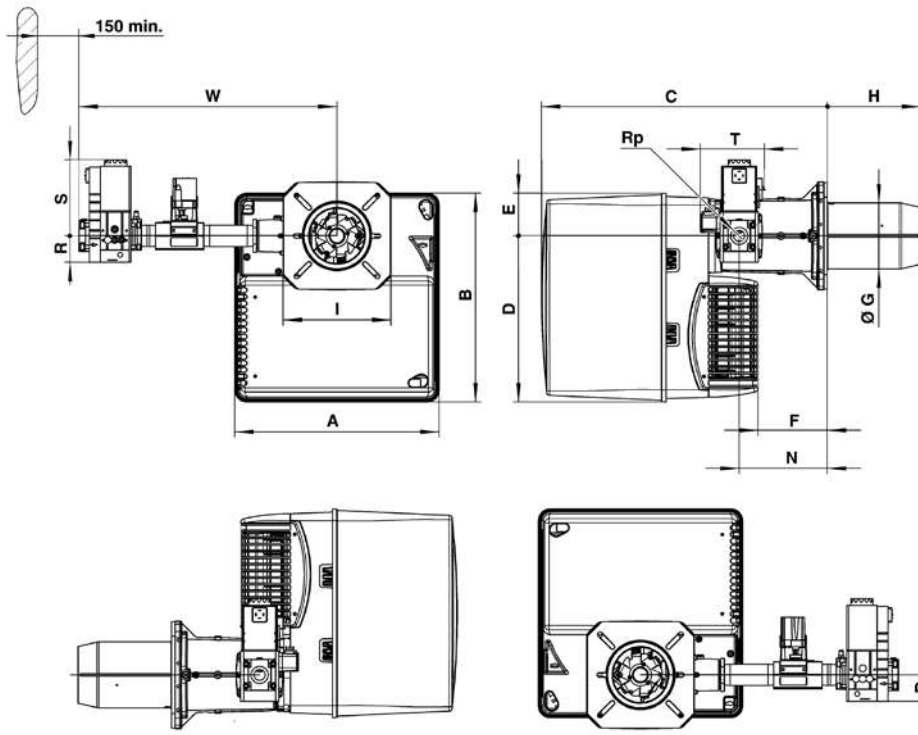

Gas train model	A	B	C	D	E	F	ØG	H		I	N	Rp	R	S	T	W
								KN	KL							
d1"1/2-Rp1"1/2/TC	465	475	640	377	97	149	150	220	360	245	195	1"1/2	80	185	160	649
d3/4"-Rp1"1/4/TC	465	475	640	377	97	149	150	220	360	245	195	1"1/4	60	173	146	587

Connecting flange

Øa (mm)	b (mm)	c	d
180-240	200-270	M10	45°

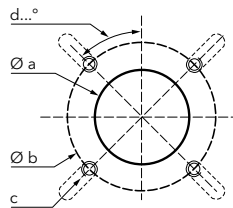

PACKAGING

The burner is delivered on a pallet in 3 packages containing:

- burner housing
- combustion head
- gas train and filter

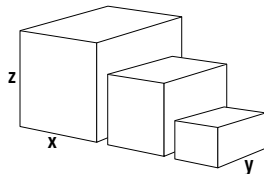

Component	Component	Dimensions (mm)			Gross weight (kg)
		X	Y	Z	
Burner body	VG4.610 M	490	490	590	32,7
Combustion head	KN	750	260	295	8,9
	KL	895	260	295	10,1
Gas train	d1"1/2-Rp1"1/2/TC	670	540	380	12
	d3/4"-Rp1"1/4/TC	670	540	380	12

**VG4.610 M**

90 ... 610 kW  
2 stage progressive/modulating electronic (Low NOx class 3)

**PRESSURE LOSS [BURNER HEAD + GAS TRAIN] (mbar)**

**VG4.610 M**

Burner output (kW)	Natural gas G20 Hi = 10,35 kWh/m <sup>3</sup>		Natural gas G25 Hi = 8,83 kWh/m <sup>3</sup>	
	d3/4"-Rp1"1/4	d1"1/2-Rp1"1/2	d3/4"-Rp1"1/4	d1"1/2-Rp1"1/2
400	23	8	32	10
450	29	10	40	12
500	35	12	50	15
550	42	14	61	18
600	50	16	73	22

**Natural gas G20**

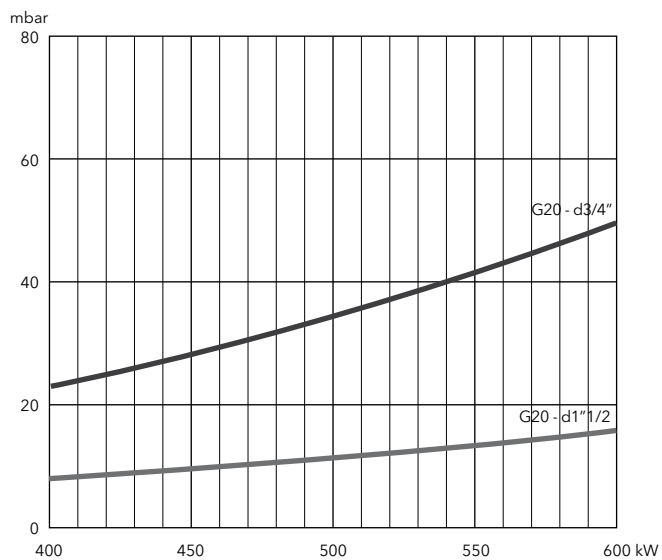

**Natural gas G25**

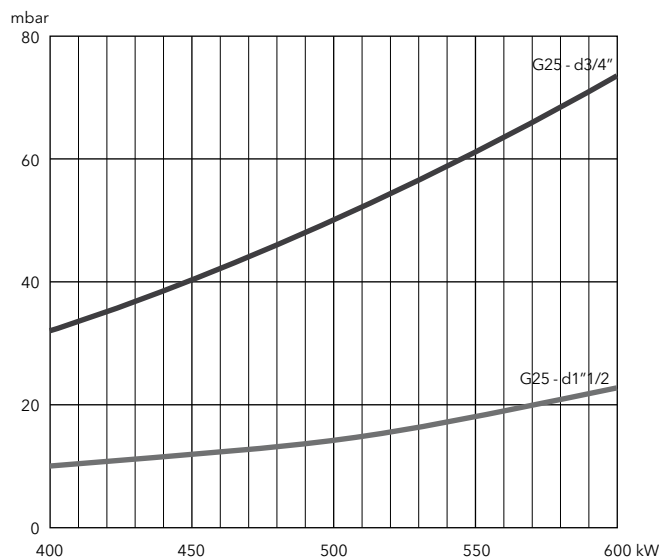



**PRESSURE LOSS [BURNER HEAD + GAS TRAIN] (mbar)**

Burner output (kW)	Natural gas G25 Hi = 8,83 kWh/m <sup>3</sup>	
	d3/4"-Rp1"1/4	
400	13	
450	15	
500	18	
550	21	
600	25	

**LPG**

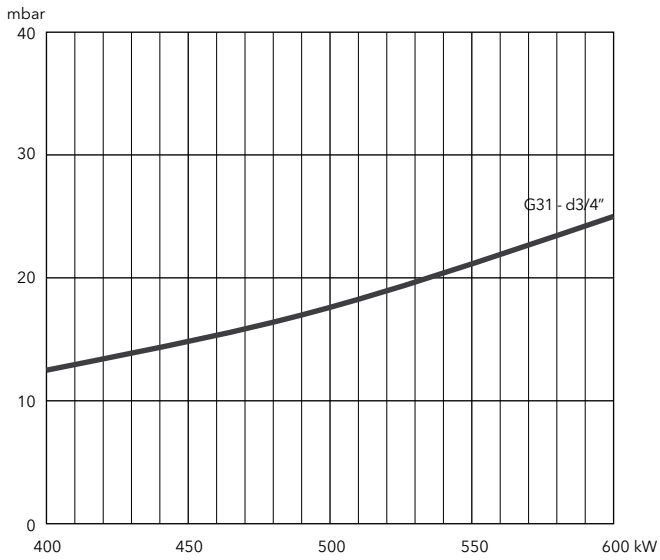

**VG5.950 M, VG5.1200 M**

160 ... 1160 kW  
2 stage progressive/modulating electronic (Low NOx class 3)



- **Fuels:** natural gas (G20/G25,  $H_u = 8,83...10,35 \text{ kWh/m}^3$ ); LPG (G31,  $H_u = 25,89 \text{ kWh/m}^3$ )
- **Emissions:** Low NOx class 3 ( $\leq 80 \text{ mg/kWh}$ ) according to EN676
- **Operation:** two stage progressive or modulating with the installation of a power regulator and dedicated probes (see pag. 180)
- **Protection level:** IP 21

**TECHNICAL DATA**

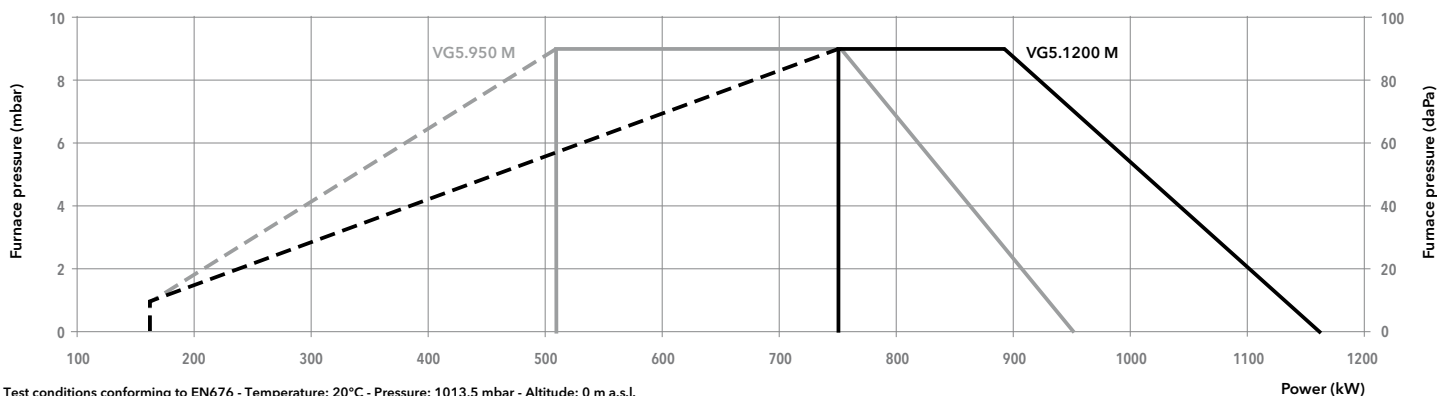

Test conditions conforming to EN676 - Temperature: 20°C - Pressure: 1013,5 mbar - Altitude: 0 m a.s.l.

Model	VG5.950 M /TC			VG5.1200 M /TC			
Operation range	(160) 510 - 950 kW			(160) 750 - 1160 kW			
Gas pressure	20 - 300 mbar			20 - 300 mbar			
Control box / flame detection	BT3... / ionization			BT3... / ionization			
Fan motor	230/400 V - 50 Hz - 1,5 kW			230/400 V - 50 Hz - 1,5 kW			
Electrical consumption	55 + 1750 W			55 + 2100 W			
Acoustic level (LpA)	77 dB(A)			77 dB(A)			
CE certificate	0085 CN 0192			0085 CN 0192			
Head lenght	KN	KL	KM	KN	KL	KM	
Complete burner code	VG40-065 s65-DN65/TC	3833999	3834000	3834001	3834005	3834006	3834007
	MBC1900 d65-DN65/TC	3833996	3833997	3833998	3834002	3834003	3834004
	MBC1200 d2"-Rp2"/TC	3833803	3833804	3833805	3833809	3833810	3833811
	MBC700 d1"1/2-Rp2"/TC	3833800	3833801	3833802	3833806	3833807	3833808
	MBC300 d3/4"-Rp1"1/4/TC	3834099	3834100	3834101	3834102	3834103	3834104

**OTHER AVAILABLE VERSIONS**

- Venr** Versions for continuous ventilation and post-ventilation
- PED** PED version for continuous operation

**SCOPE OF SUPPLY**

- The burner is delivered in its package complete with:
- 1 burner head with flange seal and securing screws
  - 1 compact gas train with gas filter; the gas filter is built-in for threaded valves (up to 2") and separated for flanged ones (DN65/80/100)
  - 1 bag containing installation fittings
  - 1 bag containing technical documentation (instruction manual, technical data, electrical diagram, exploded view and spare parts list)





**DIMENSIONS (mm)**

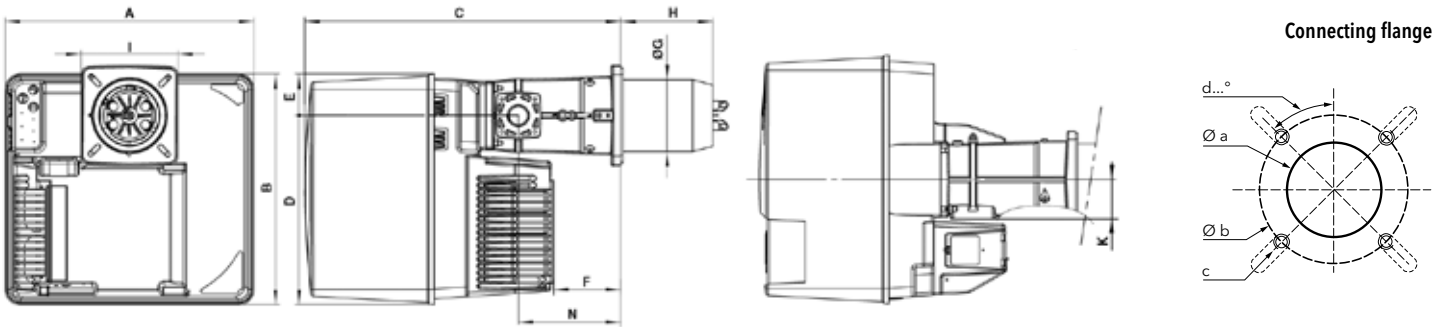

A	B	C	D	E	F	ØG	H			I	K	N
							KN	KM	KL			
581	549	752	450	99	164	170	215	325	435	230x238	89	244

Øa (mm)	b (mm)	c	d
195	220-260	M10	45°

**Gas trains**

Gas train "d":

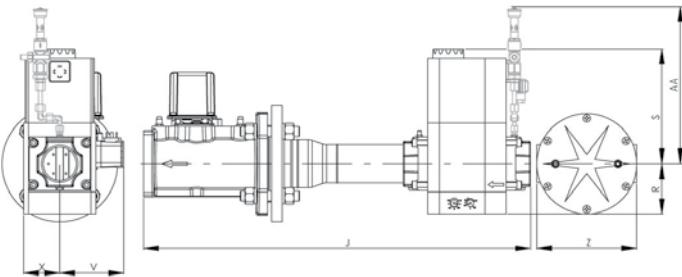

Model	J	R	S	V	X	Z	AA*
d65-DN65	490	183	245	110	98	290	385
d2"-Rp2"	700	96	330	125	81	-	385
d1"1/2-Rp2"	622	80	185	102	57	-	320
d3/4"-Rp1"1/4	460	60	173	88	58	-	320

Gas train "s":

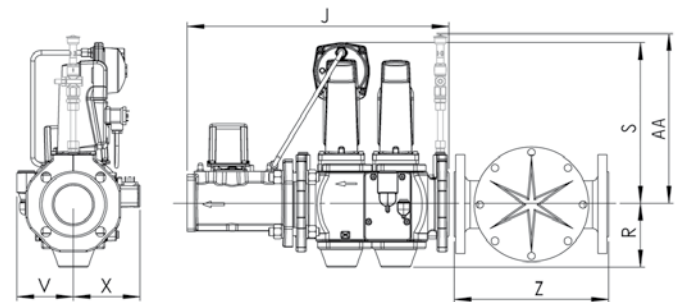

Model	J	R	S	V	X	Z	AA*
s65-DN65	490	118	300	106	126	290	365

\*: for PED configuration

**PACKAGING**

The burner is delivered on a pallet in 3 packages containing:

- burner housing
- combustion head
- gas train and filter

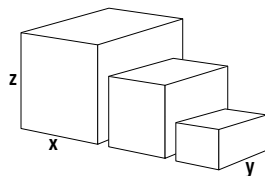

Component		Dimensions (mm)			Gross weight (kg)
		X	Y	Z	
Burner body	VG5.950 M	800	600	850	56
	VG5.1200 M	800	600	850	56
Combustion head	KN	780	265	280	12,3
	KL	1010	265	280	14,4
	KM	1010	265	280	13,4
Gas train	s65-DN65/TC	670	550	380	29
	d65-DN65/TC	670	550	380	33
	d2"-Rp2"/TC	670	550	380	22
	d1"1/2-Rp2"/TC	670	550	380	21
	d3/4"-Rp1"1/4/TC	670	550	380	12

**VG5.950 M, VG5.1200 M**

160 ... 1160 kW  
2 stage progressive/modulating electronic (Low NOx class 3)

**PRESSURE LOSS [BURNER HEAD + GAS TRAIN] (mbar)**

**VG5.950 M**

Burner output (kW)	Natural gas G20 Hi = 10,35 kWh/m <sup>3</sup>					Natural gas G25 Hi = 8,83 kWh/m <sup>3</sup>					LPG G31
	d3/4-Rp1"1/4	d1"1/2-Rp2"	d2"-Rp2"	d65-DN65	s65-DN65	d3/4-Rp1"1/4	d1"1/2-Rp2"	d2"-Rp2"	d65-DN65	s65-DN65	d1"1/2-Rp2"
500	31	9	8	5	5	37	11	9	5	6	6
600	43	13	10	8	8	53	16	12	7	9	8
700	58	17	13	10	10	73	21	15	10	12	10
800	76	22	16	13	13	96	28	19	13	16	13
900	97	27	19	17	17	124	35	23	17	20	16

**Natural gas G20**

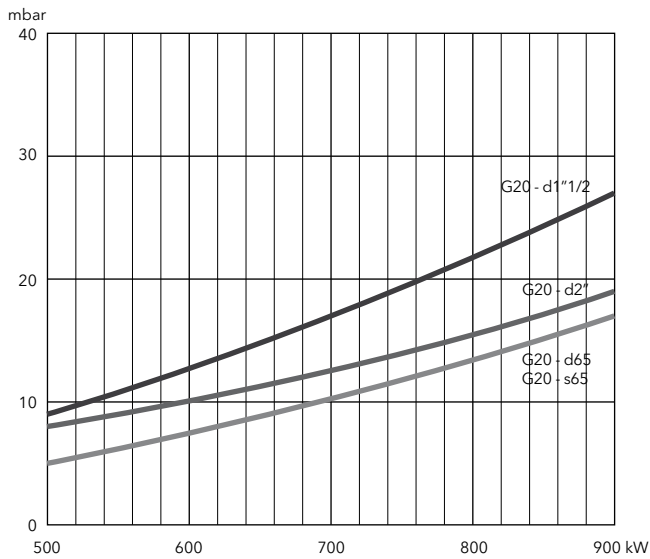

**Natural gas G25**

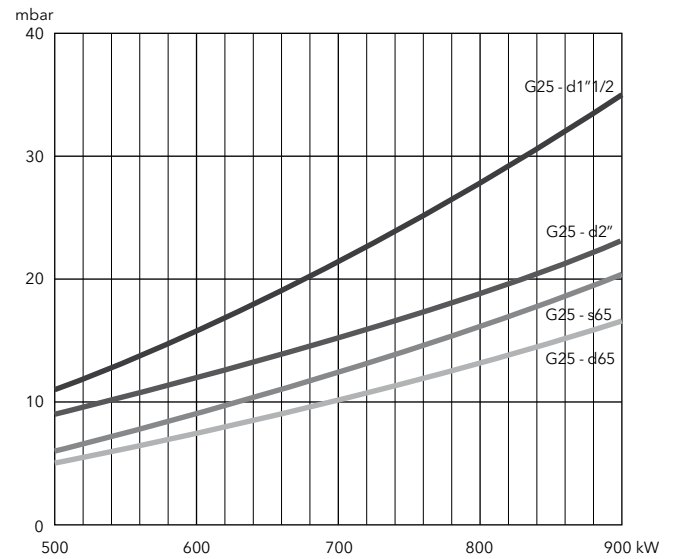

**Natural gas G20, G25**

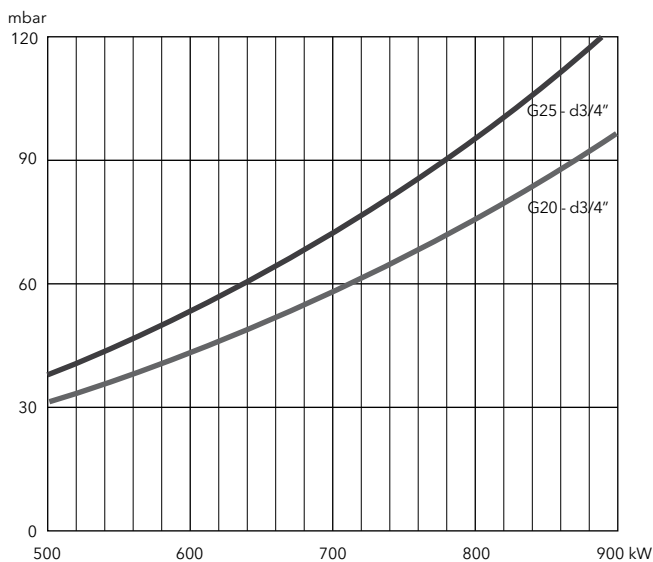

**LPG**

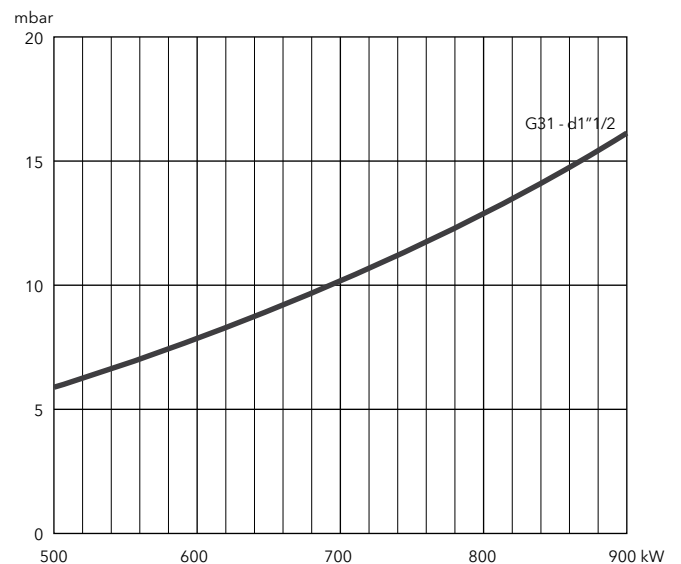



**PRESSURE LOSS [BURNER HEAD + GAS TRAIN] (mbar)**

**VG5.1200 M**

Burner output (kW)	Natural gas G20 Hi = 10,35 kWh/m <sup>3</sup>					Natural gas G25 Hi = 8,83 kWh/m <sup>3</sup>					LPG G31
	d3/4-Rp1"1/4	d1"1/2-Rp2"	d2"-Rp2"	d65-DN65	s65-DN65	d3/4-Rp1"1/4	d1"1/2-Rp2"	d2"-Rp2"	d65-DN65	s65-DN65	d1"1/2-Rp2"
700	40	16	12	10	10	60	21	14	10	12	10
800	53	20	14	13	13	79	27	17	13	15	12
900	68	25	17	16	16	100	34	21	16	19	15
1000	84	31	21	20	20	126	42	26	20	24	18
1100	103	37	25	24	24	154	50	31	24	29	22
1200	123	44	29	29	29	186	59	36	29	34	26

**Natural gas G20**

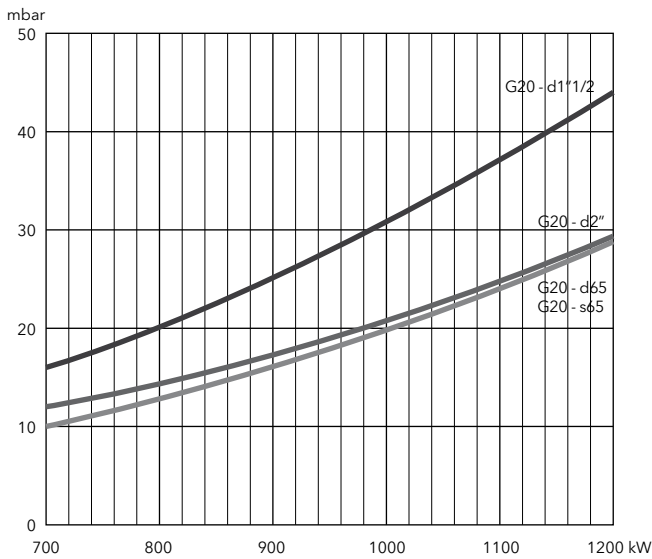

**Natural gas G25**

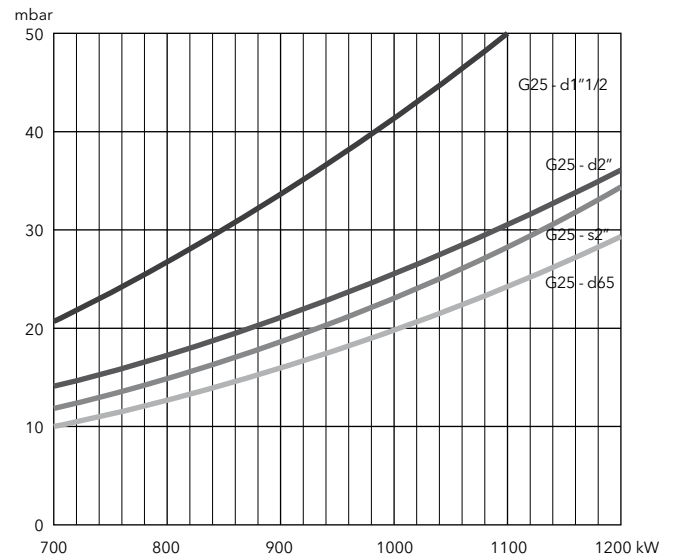

**Natural gas G20, G25**

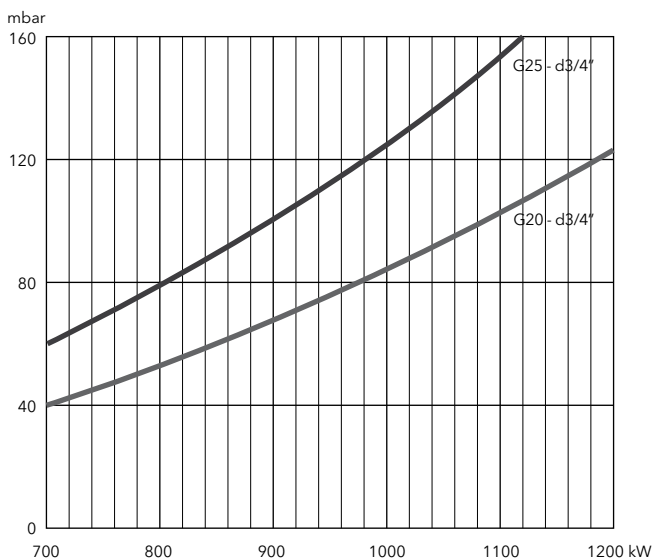

**LPG**

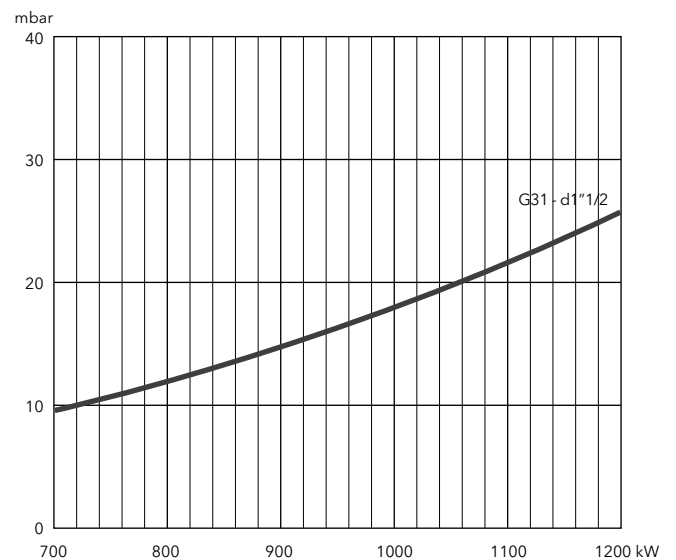

**VG6.1600 M, VG6.2100 M**

240 ... 1900 kW  
2 stage progressive/modulating electronic (Low NOx class 3)

- **Fuels:** natural gas (G20/G25,  $H_u = 8,83...10,35 \text{ kWh/m}^3$ );  
LPG (G31,  $H_u = 25,89 \text{ kWh/m}^3$ )
- **Emissions:** Low NOx class 3 ( $\leq 80 \text{ mg/kWh}$ ) according to EN676
- **Operation:** two stage progressive or modulating with the installation of a power regulator and dedicated probes (see pag. 180)
- **Protection level:** IP 21



**TECHNICAL DATA**

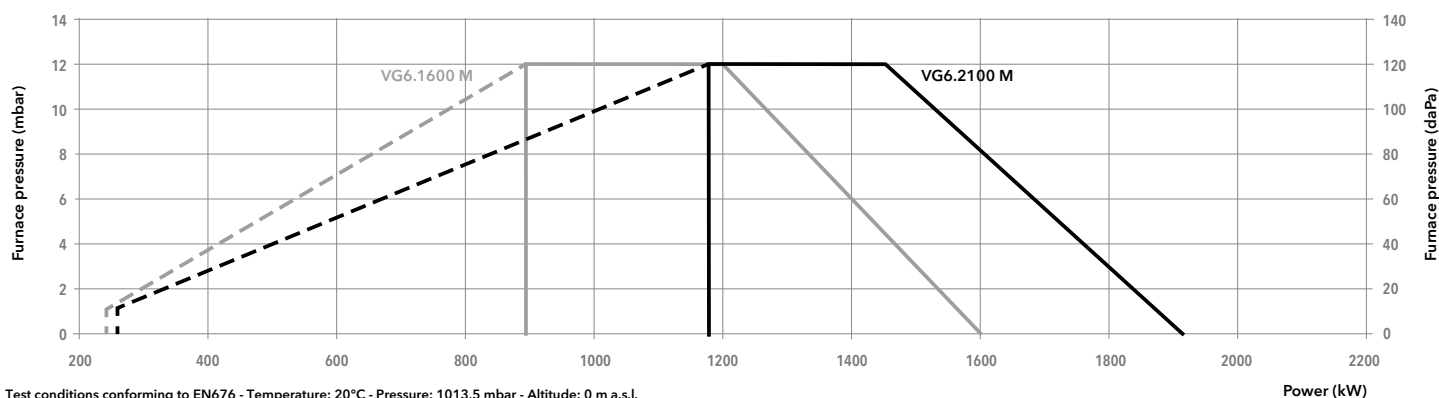

Model	VG6.1600 M /TC			VG6.2100 M /TC			
Operation range	(240) 890 - 1600 kW			(260) 1180 - 1900 kW			
Gas pressure	20 - 300 mbar			20 - 300 mbar			
Control box / flame detection	BT3... / ionization			BT3... / ionization			
Fan motor	230/400 V - 50 Hz - 2,2 kW			230/400 V - 50 Hz - 2,7 kW			
Electrical consumption	55 + 2600 W			55 + 3400 W			
Acoustic level (LpA)	77,2 dB(A)			79 dB(A)			
CE certificate	0085 CN 0192			0085 CN 0192			
Head lenght	KN	KL	KM	KN	KL	KM	
Complete	VGD 40-065 s65-DN65/TC	3833938	3833939	3833940	3833934	3833933	3833930
burner code	MBC1900 d65-DN65/TC	3833836	3833837	3833838	3833845	3833846	3833847
	MBC1200 d2"-Rp2"/TC	3833833	3833834	3833835	3833842	3833843	3833844
	MBC700 d1"1/2-Rp2"/TC	3833830	3833831	3833832	3833839	3833840	3833841

**OTHER AVAILABLE VERSIONS**

- Vent** Versions for continuous ventilation and post-ventilation
- PED** PED version for continuous operation

**SCOPE OF SUPPLY**

- The burner is delivered in its package complete with:
- 1 burner head with flange seal and securing screws
  - 1 compact gas train with gas filter; the gas filter is built-in for threaded valves (up to 2") and separated for flanged ones (DN65/80/100)
  - 1 bag containing installation fittings
  - 1 bag containing technical documentation (instruction manual, technical data, electrical diagram, exploded view and spare parts list)



**DIMENSIONS (mm)**

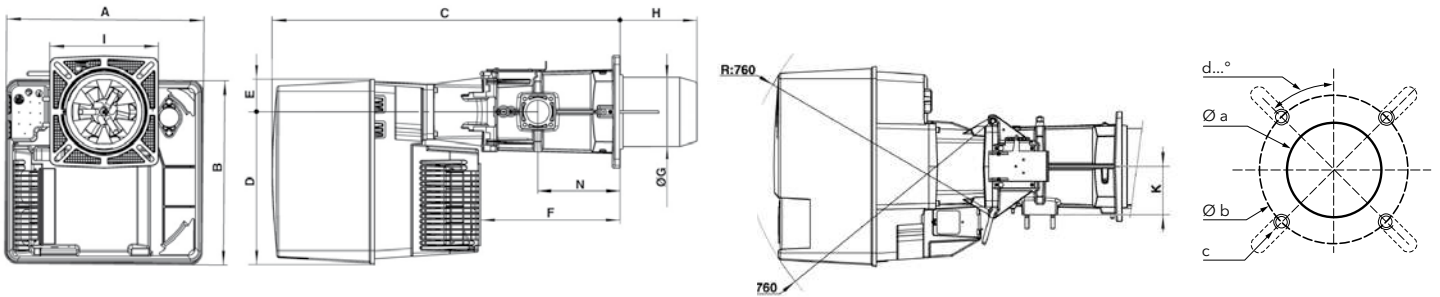

A	B	C	D	E	F	ØG	H			I	K	N
							KN	KM	KL			
592	553	1050	456	97	421	227	360	460	560	326x335	144	247

Øa (mm)	b (mm)	c	d
250	300-400	M12	45°

**Gas trains**

Gas train "d":

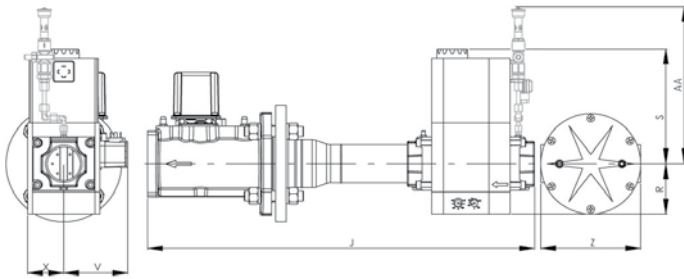

Model	J	R	S	V	X	Z	AA*
d65-DN65	490	183	245	110	98	290	385
d2"-Rp2"	700	96	330	125	81	-	385
d1"1/2-Rp2"	622	80	185	102	57	-	320

Gas train "s":

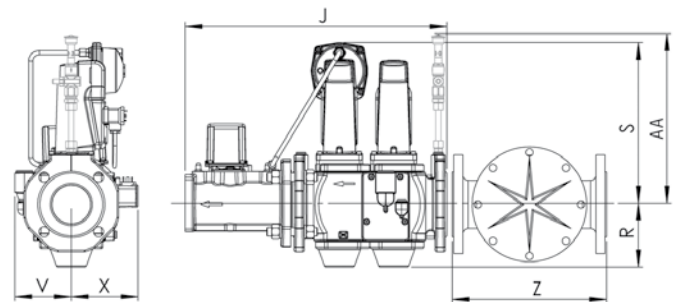

Model	J	R	S	V	X	Z	AA*
s65-DN65	490	118	300	106	126	290	365

\*: for PED configuration

**PACKAGING**

The burner is delivered on a pallet in 3 packages containing:

- burner housing
- combustion head
- gas train and filter

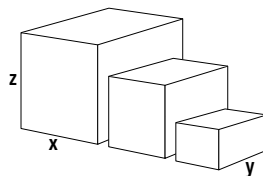

Component		Dimensions (mm)			Gross weight (kg)
		X	Y	Z	
Burner body	VG6.1600 M	800	600	850	56
	VG6.2100 M	800	600	850	56
Combustion head	KN	1000	380	420	26,7
	KL	1100	380	430	29,4
	KM	1100	380	430	28
Gas train	s65-DN65/TC	790	600	500	29,4
	d65-DN65/TC	670	550	380	33
	d2"-Rp2"/TC	670	550	380	22
	d1"1/2-Rp2"/TC	670	550	380	21

**VG6.1600 M, VG6.2100 M**

240 ... 1900 kW  
2 stage progressive/modulating electronic (Low NOx class 3)

**PRESSURE LOSS [BURNER HEAD + GAS TRAIN] (mbar)**

**VG6.1600 M**

Burner output (kW)	Natural gas G20 Hi = 10,35 kWh/m <sup>3</sup>				Natural gas G25 Hi = 8,83 kWh/m <sup>3</sup>				LPG G31 Hi = 25,89 kWh/m <sup>3</sup>
	d1"1/2-Rp2"	d2"-Rp2"	d65-DN65	s65-DN65	d1"1/2-Rp2"	d2"-Rp2"	d65-DN65	s65-DN65	d1"1/2-Rp2"
800	16	9	6	6	22	12	8	8	8
1000	25	13	10	9	34	18	12	12	12
1200	35	18	14	13	48	24	18	18	17
1400	47	24	19	18	64	32	24	24	22
1600	61	31	25	23	83	42	31	31	29

**Natural gas G20**

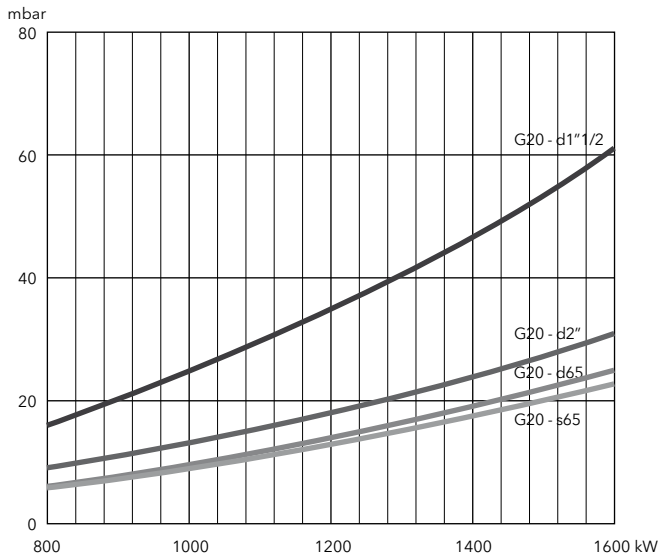

**Natural gas G25**

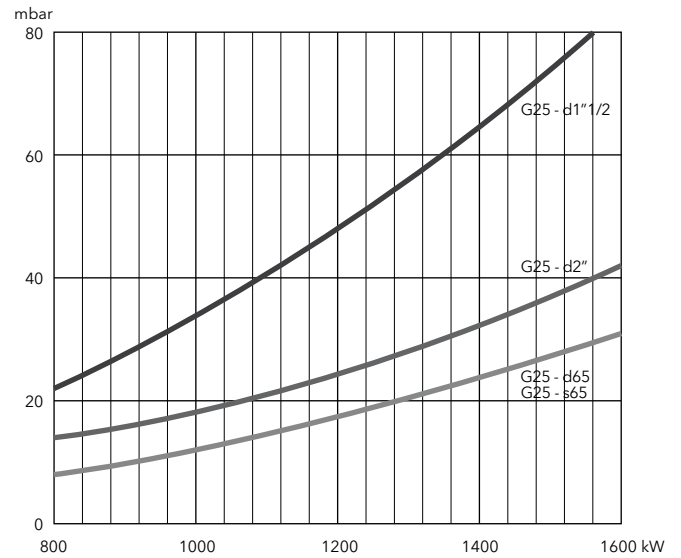

**LPG**

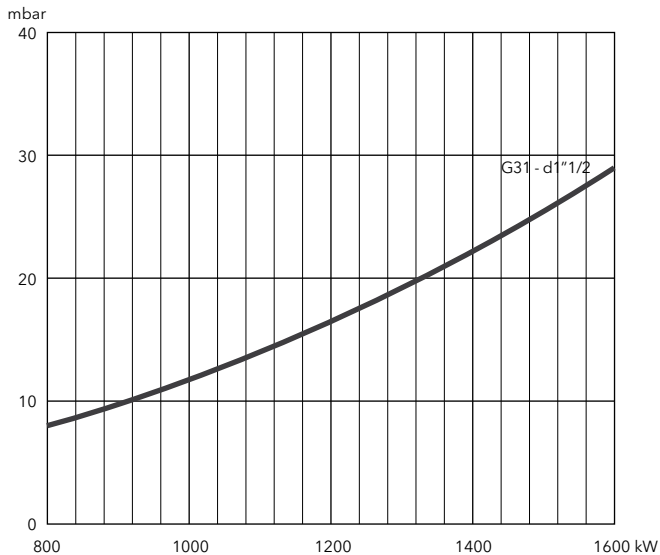



**PRESSURE LOSS [BURNER HEAD + GAS TRAIN] (mbar)**

**VG6.2100 M**

Burner output (kW)	Natural gas G20 Hi = 10,35 kWh/m <sup>3</sup>				Natural gas G25 Hi = 8,83 kWh/m <sup>3</sup>				LPG G31 Hi = 25,89 kWh/m <sup>3</sup>	
	d1"1/2-Rp2"	d2"-Rp2"	d65-DN65	s65-DN65	d1"1/2-Rp2"	d2"-Rp2"	d65-DN65	s65-DN65	d1"1/2-Rp2"	d2"-Rp2"
1100	28	15	12	11	39	21	15	15	13	9
1300	39	21	16	16	54	29	21	22	18	11
1500	51	27	21	21	71	37	28	29	23	14
1700	64	34	27	27	91	47	36	37	29	17
1900	80	41	34	34	114	59	45	46	36	20

**Natural gas G20**

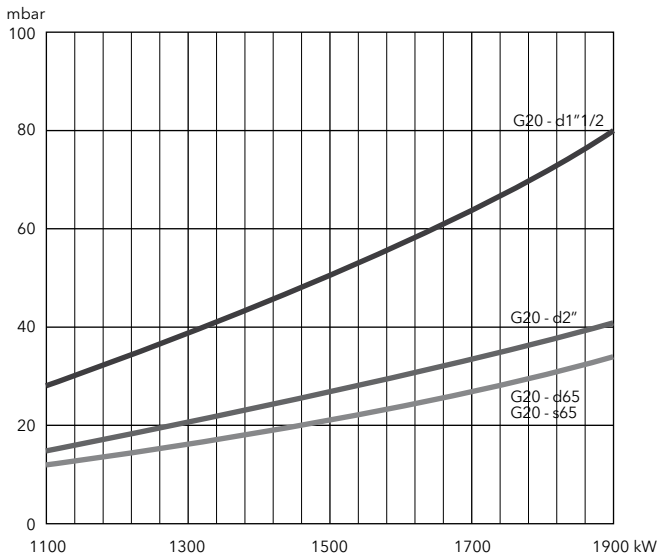

**Natural gas G25**

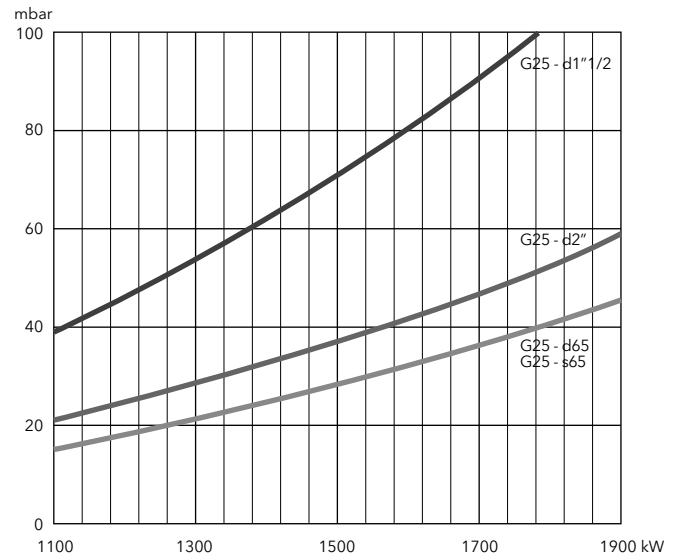

**LPG**

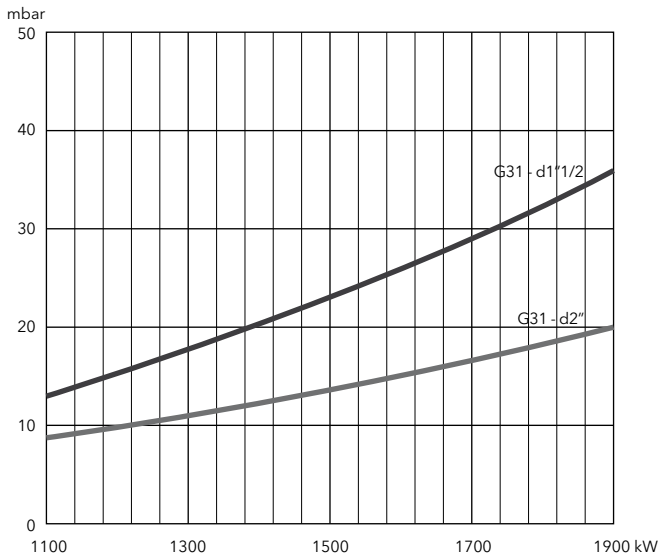

**VG5.950 M V, VG5.1200 M V**

160 ... 1160 kW  
2 stage progressive/modulating electronic (Low NOx class 3) + fan speed control



- **Fuels:** natural gas (G20/G25,  $H_u = 8,83...10,35 \text{ kWh/m}^3$ ); LPG (G31,  $H_u = 25,89 \text{ kWh/m}^3$ )
- **Emissions:** Low NOx class 3 ( $\leq 80 \text{ mg/kWh}$ ) according to EN676
- **Operation:** two stage progressive or modulating with the installation of a power regulator and dedicated probes (see pag. 180)
- **Protection level:** IP 21

**TECHNICAL DATA**

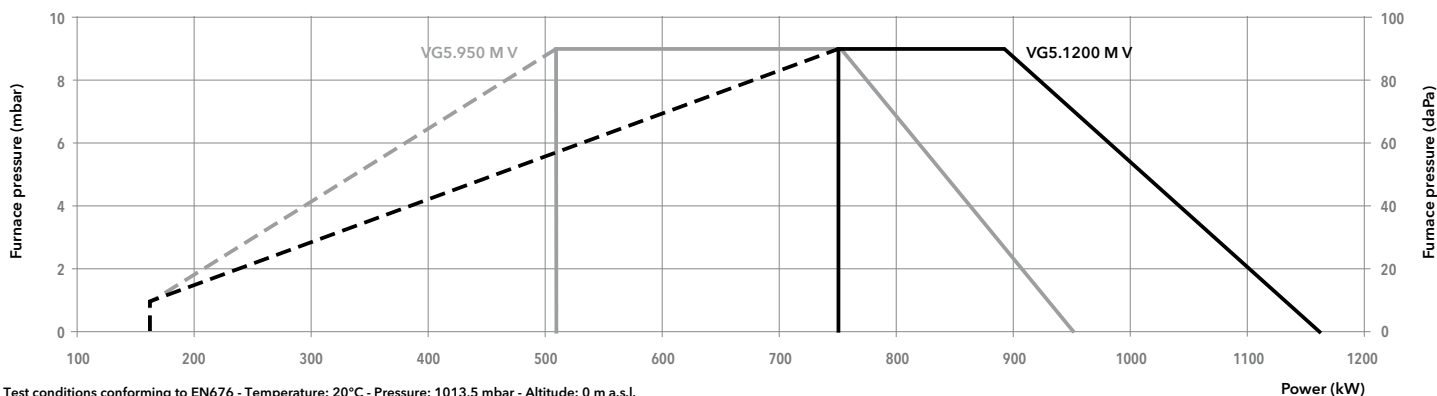

Model	VG5.950 M V /TC			VG5.1200 M V /TC			
Operation range	(160) 510 - 950 kW			(160) 750 - 1160 kW			
Gas pressure	20 - 300 mbar			20 - 300 mbar			
Control box / flame detection	BT3... / ionization			BT3... / ionization			
Fan motor	230/400 V - 50 Hz - 1,5 kW			230/400 V - 50 Hz - 1,5 kW			
Electrical consumption	55 + 1750 W			55 + 2100 W			
Acoustic level (LpA)	77 dB(A)			77 dB(A)			
CE certificate	0085 CN 0192			0085 CN 0192			
Head lenght	KN	KL	KM	KN	KL	KM	
Complete burner code	VG40-065 s65-DN65/TC	3835235	3835245	3835255	3835240	3835250	3835260
	MBC1900 d65-DN65/TC	3835236	3835246	3835256	3835241	3835251	3835261
	MBC1200 d2"-Rp2"/TC	3835237	3835247	3835257	3835242	3835252	3835262
	MBC700 d1"1/2-Rp2"/TC	3835238	3835248	3835258	3835243	3835253	3835263
	MBC300 d3/4"-Rp1"1/4/TC	3835239	3835249	3835259	3835244	3835254	3835264

**OTHER AVAILABLE VERSIONS**

- Vent** Versions for continuous ventilation and post-ventilation
- PED** PED version for continuous operation

**SCOPE OF SUPPLY**

- The burner is delivered in its package complete with:
- 1 burner head with flange seal and securing screws
  - 1 compact gas train with gas filter; the gas filter is built-in for threaded valves (up to 2") and separated for flanged ones (DN65/80/100)
  - 1 bag containing installation fittings
  - 1 bag containing technical documentation (instruction manual, technical data, electrical diagram, exploded view and spare parts list)





**DIMENSIONS (mm)**

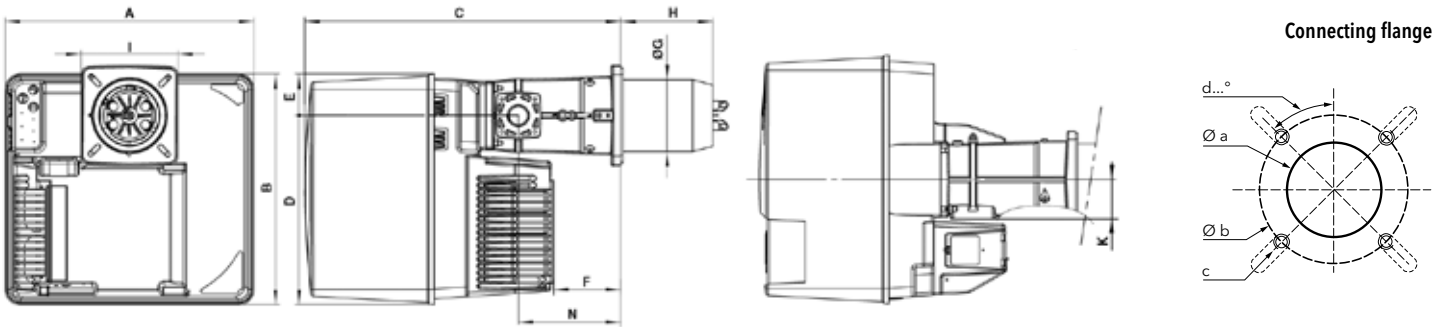

A	B	C	D	E	F	ØG	H			I	K	N
							KN	KM	KL			
581	549	752	450	99	164	170	215	325	435	230x238	89	244

Øa (mm)	b (mm)	c	d
195	220-260	M10	45°

**Gas trains**

Gas train "d":

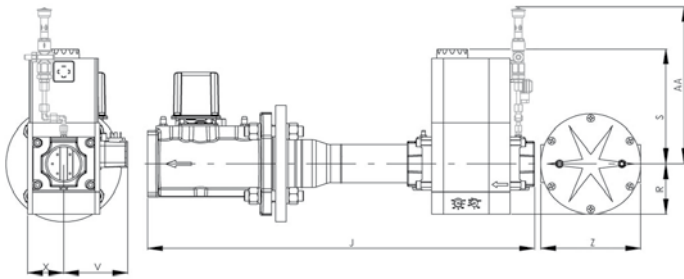

Model	J	R	S	V	X	Z	AA*
d65-DN65	490	183	245	110	98	290	385
d2"-Rp2"	700	96	330	125	81	-	385
d1 1/2"-Rp2"	622	80	185	102	57	-	320
d3/4"-Rp1 1/4"	460	60	173	88	58	-	320

Gas train "s":

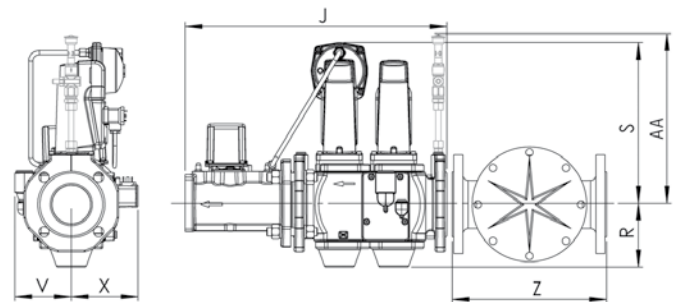

Model	J	R	S	V	X	Z	AA*
s65-DN65	490	118	300	106	126	290	365

\*: for PED configuration

**PACKAGING**

The burner is delivered on a pallet in 3 packages containing:

- burner housing
- combustion head
- gas train and filter

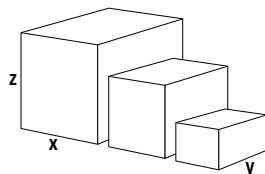

Component		Dimensions (mm)			Gross weight (kg)
		X	Y	Z	
Burner body	VG5.950 M V	800	600	850	56
	VG5.1200 M V	800	600	850	56
Combustion head	KN	780	265	280	12,3
	KL	1010	265	280	14,4
	KM	1010	265	280	13,4
Gas train	s65-DN65/TC	670	550	380	29
	d65-DN65/TC	670	550	380	33
	d2"-Rp2"/TC	670	550	380	22
	d1 1/2"-Rp2"/TC	670	550	380	21
	d3/4"-Rp1 1/4"/TC	590	290	180	12

**VG5.950 M V, VG5.1200 M V**

160 ... 1160 kW

2 stage progressive/modulating electronic (Low NOx class 3) + fan speed control

**PRESSURE LOSS [BURNER HEAD + GAS TRAIN] (mbar)**

**VG5.950 M V**

Burner output (kW)	Natural gas G20 Hi = 10,35 kWh/m <sup>3</sup>					Natural gas G25 Hi = 8,83 kWh/m <sup>3</sup>					LPG G31
	d3/4-Rp1"1/4	d1"1/2-Rp2"	d2"-Rp2"	d65-DN65	s65-DN65	d3/4-Rp1"1/4	d1"1/2-Rp2"	d2"-Rp2"	d65-DN65	s65-DN65	d1"1/2-Rp2"
500	31	9	8	5	5	37	11	9	5	6	6
600	43	13	10	8	8	53	16	12	7	9	8
700	58	17	13	10	10	73	21	15	10	12	10
800	76	22	16	13	13	96	28	19	13	16	13
900	97	27	19	17	17	124	35	23	17	20	16

**Natural gas G20**

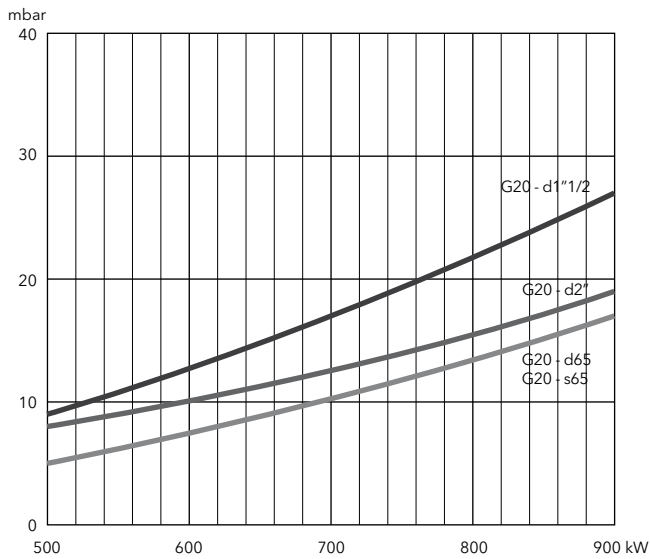

**Natural gas G25**

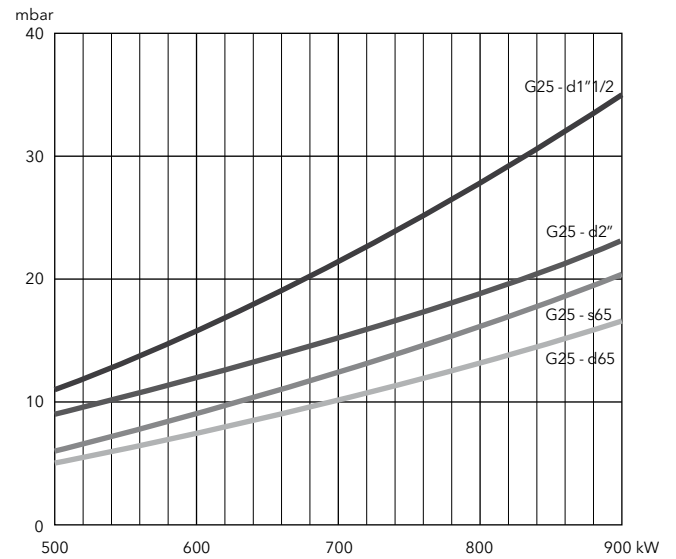

**Natural gas G20, G25**

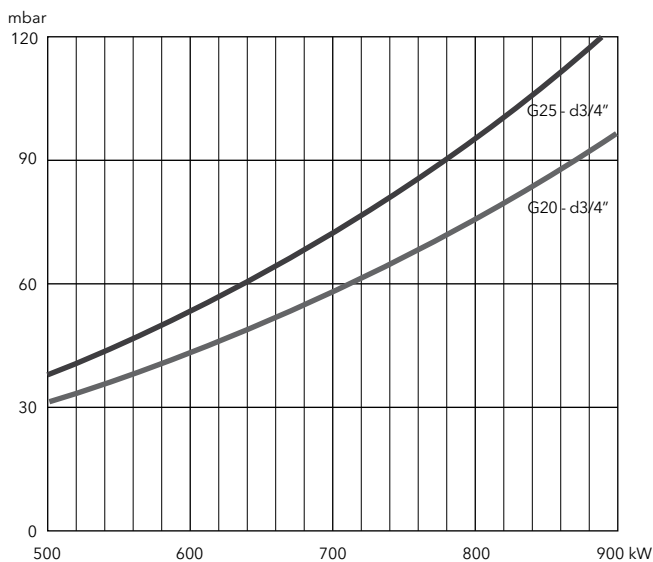

**LPG**

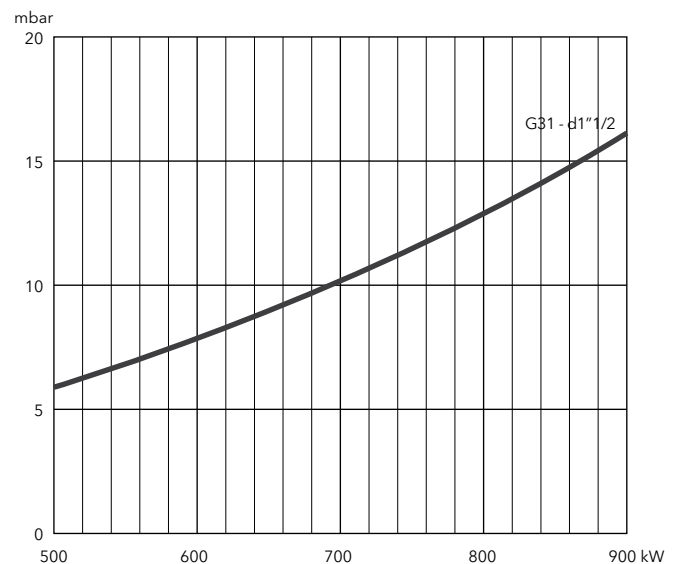



**PRESSURE LOSS [BURNER HEAD + GAS TRAIN] (mbar)**

**VG5.1200 M V**

Burner output (kW)	Natural gas G20 Hi = 10,35 kWh/m <sup>3</sup>					Natural gas G25 Hi = 8,83 kWh/m <sup>3</sup>					LPG G31
	d3/4-Rp1"1/4	d1"1/2-Rp2"	d2"-Rp2"	d65-DN65	s65-DN65	d3/4-Rp1"1/4	d1"1/2-Rp2"	d2"-Rp2"	d65-DN65	s65-DN65	d1"1/2-Rp2"
700	40	16	12	10	10	60	21	14	10	12	10
800	53	20	14	13	13	79	27	17	13	15	12
900	68	25	17	16	16	100	34	21	16	19	15
1000	84	31	21	20	20	126	42	26	20	24	18
1100	103	37	25	24	24	154	50	31	24	29	22
1200	123	44	29	29	29	186	59	36	29	34	26

**Natural gas G20**

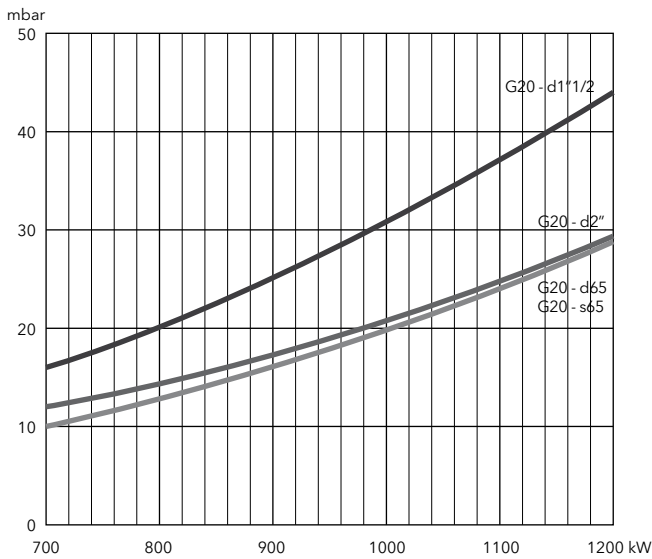

**Natural gas G25**

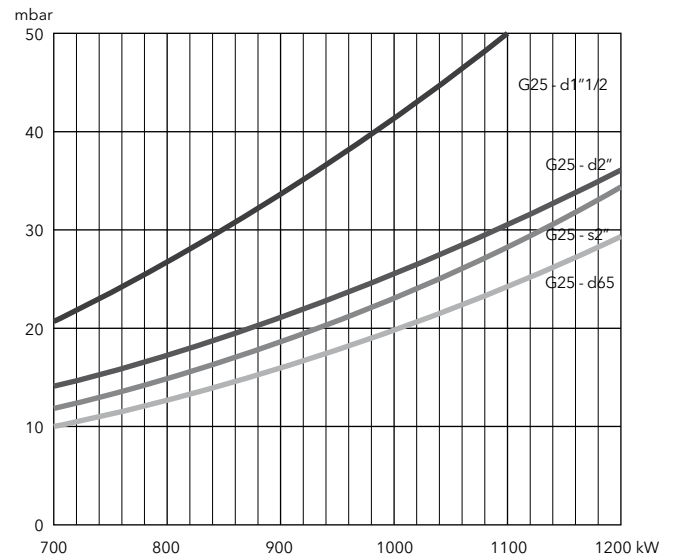

**Natural gas G20, G25**

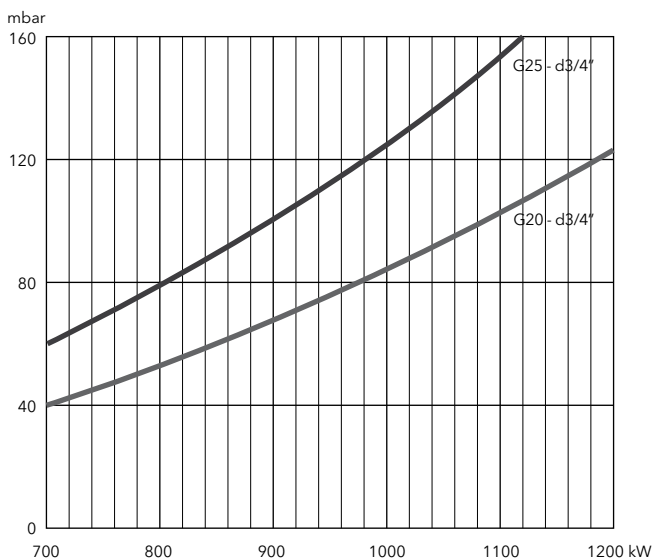

**LPG**

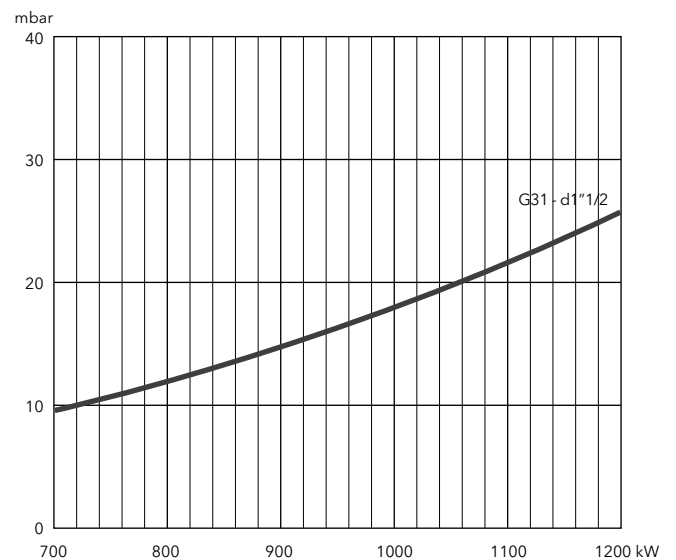

**VG6.1600 M V, VG6.2100 M V**

240 ... 1900 kW

2 stage progressive/modulating electronic (Low NOx class 3) + fan speed control

- **Fuels:** natural gas (G20/G25,  $H_u = 8,83...10,35 \text{ kWh/m}^3$ );  
LPG (G31,  $H_u = 25,89 \text{ kWh/m}^3$ )
- **Emissions:** Low NOx class 3 ( $\leq 80 \text{ mg/kWh}$ ) according to EN676
- **Operation:** two stage progressive or modulating with the installation of a power regulator and dedicated probes (see pag. 180)
- **Protection level:** IP 21



**TECHNICAL DATA**

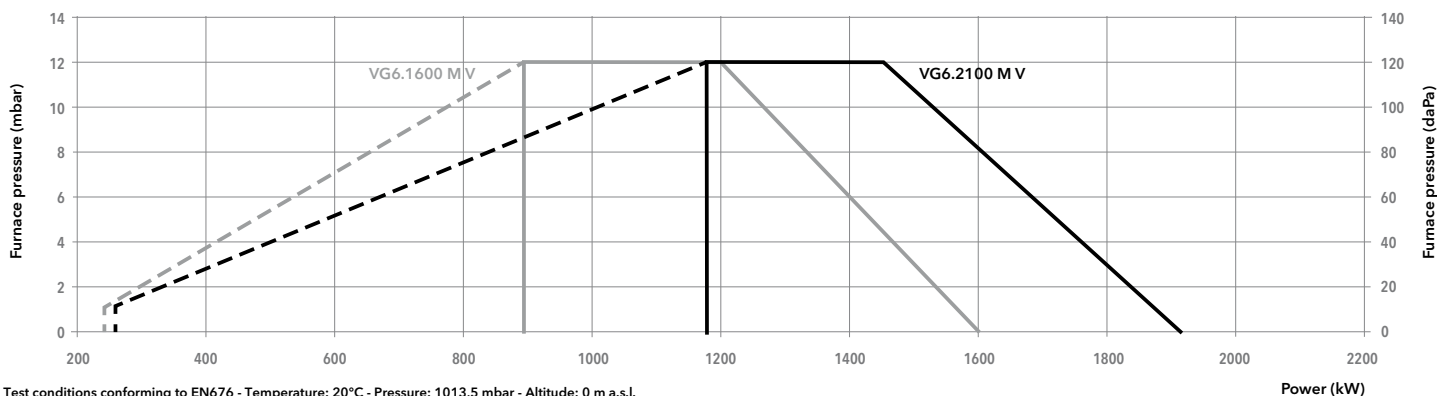

Test conditions conforming to EN676 - Temperature: 20°C - Pressure: 1013,5 mbar - Altitude: 0 m a.s.l.

Model	VG6.1600 M V /TC			VG6.2100 M V /TC			
Operation range	(240) 890 - 1600 kW			(260) 1180 - 1900 kW			
Gas pressure	20 - 300 mbar			20 - 300 mbar			
Control box / flame detection	BT3... / ionization			BT3... / ionization			
Fan motor	230/400 V - 50 Hz - 2,2 kW			230/400 V - 50 Hz - 2,7 kW			
Electrical consumption	55 + 2600 W			55 + 3400 W			
Acoustic level (LpA)	77,2 dB(A)			79 dB(A)			
CE certificate	0085 CN 0192			0085 CN 0192			
Head lenght	KN	KL	KM	KN	KL	KM	
Complete	VGD 40-065 s65-DN65/TC	3835265	3835273	3835281	3835269	3835277	3835285
burner code	MBC1900 d65-DN65/TC	3835266	3835274	3835282	3835270	3835278	3835286
	MBC1200 d2"-Rp2"/TC	3835267	3835275	3835283	3835271	3835279	3835287
	MBC700 d1"1/2-Rp2"/TC	3835268	3835276	3835284	3835272	3835280	3835288

**OTHER AVAILABLE VERSIONS**

- Vent** Versions for continuous ventilation and post-ventilation
- PED** PED version for continuous operation

**SCOPE OF SUPPLY**

- The burner is delivered in its package complete with:
- 1 burner head with flange seal and securing screws
  - 1 compact gas train with gas filter; the gas filter is built-in for threaded valves (up to 2") and separated for flanged ones (DN65/80/100)
  - 1 bag containing installation fittings
  - 1 bag containing technical documentation (instruction manual, technical data, electrical diagram, exploded view and spare parts list)



**DIMENSIONS (mm)**

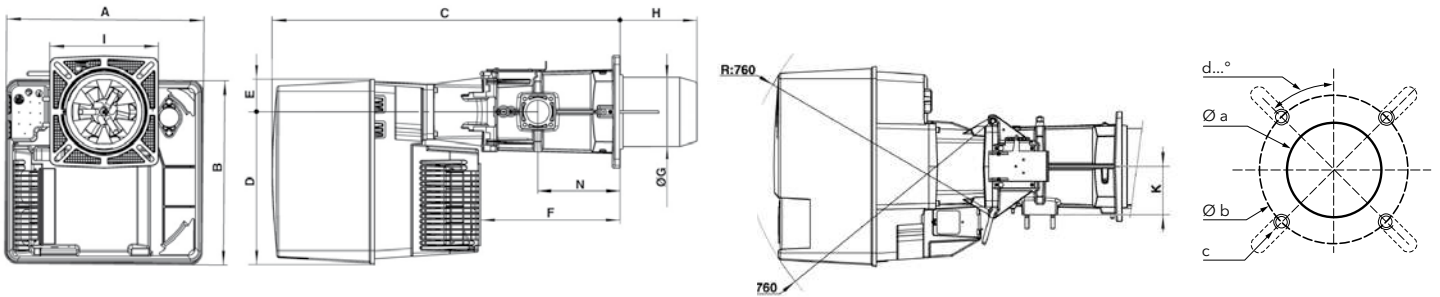

A	B	C	D	E	F	ØG	H			I	K	N
							KN	KM	KL			
592	553	1050	456	97	421	227	360	460	560	326x335	144	247

Øa (mm)	b (mm)	c	d
250	300-400	M12	45°

**Gas trains**

Gas train "d":

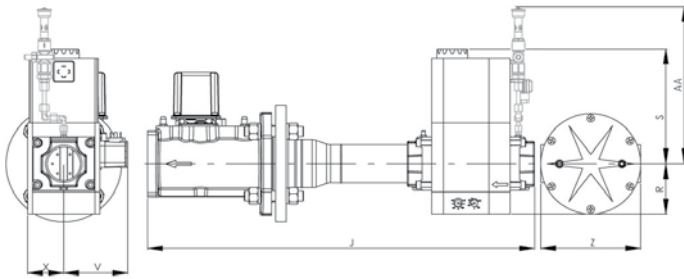

Model	J	R	S	V	X	Z	AA*
d65-DN65	490	183	245	110	98	290	385
d2"-Rp2"	700	96	330	125	81	-	385
d1"1/2-Rp2"	622	80	185	102	57	-	320

Gas train "s":

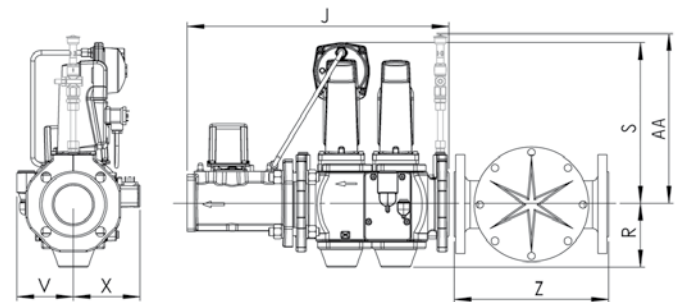

Model	J	R	S	V	X	Z	AA*
s65-DN65	490	118	300	106	126	290	365

\*: for PED configuration

**PACKAGING**

The burner is delivered on a pallet in 3 packages containing:

- burner housing
- combustion head
- gas train and filter

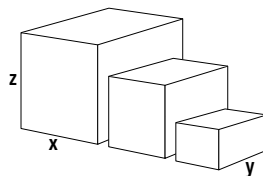

Component		Dimensions (mm)			Gross weight (kg)
		X	Y	Z	
Burner body	VG6.1600 M V	800	600	850	56
	VG6.2100 M V	800	600	850	56
Combustion head	KN	1000	380	420	26,7
	KL	1100	380	430	29,4
	KM	1100	380	430	28
Gas train	s65-DN65/TC	670	550	380	29,4
	d65-DN65/TC	670	550	380	33
	d2"-Rp2"/TC	670	550	380	22
	d1"1/2-Rp2"/TC	670	550	380	21

**VG6.1600 M V, VG6.2100 M V**

240 ... 1900 kW

2 stage progressive/modulating electronic (Low NOx class 3) + fan speed control

**PRESSURE LOSS [BURNER HEAD + GAS TRAIN] (mbar)**

**VG6.1600 M V**

Burner output (kW)	Natural gas G20 Hi = 10,35 kWh/m <sup>3</sup>				Natural gas G25 Hi = 8,83 kWh/m <sup>3</sup>				LPG G31 Hi = 25,89 kWh/m <sup>3</sup>
	d1"1/2-Rp2"	d2"-Rp2"	d65-DN65	s65-DN65	d1"1/2-Rp2"	d2"-Rp2"	d65-DN65	s65-DN65	d1"1/2-Rp2"
800	16	9	6	6	22	12	8	8	8
1000	25	13	10	9	34	18	12	12	12
1200	35	18	14	13	48	24	18	18	17
1400	47	24	19	18	64	32	24	24	22
1600	61	31	25	23	83	42	31	31	29

**Natural gas G20**

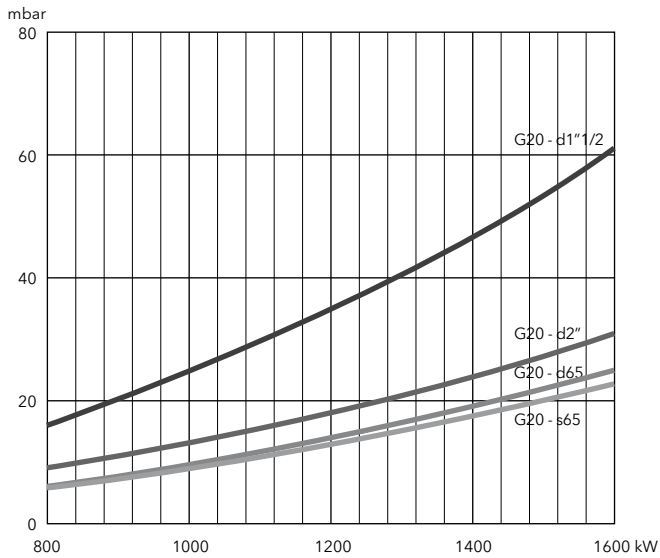

**Natural gas G25**

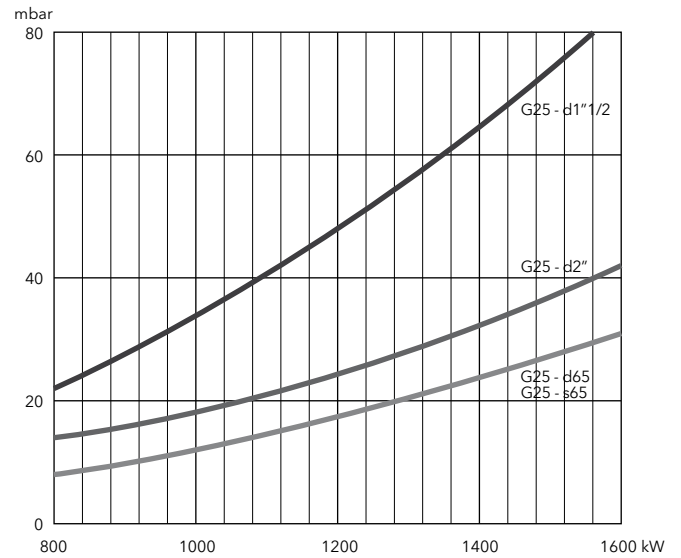

**LPG**

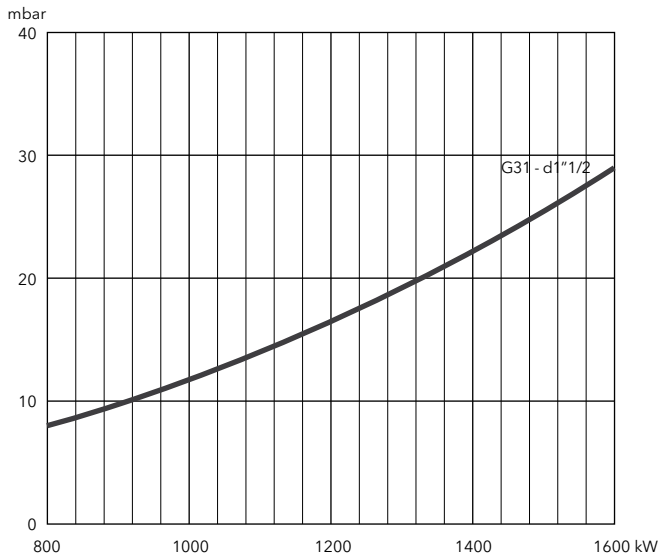



**PRESSURE LOSS [BURNER HEAD + GAS TRAIN] (mbar)**

**VG6.2100 M V**

Burner output (kW)	Natural gas G20 Hi = 10,35 kWh/m <sup>3</sup>				Natural gas G25 Hi = 8,83 kWh/m <sup>3</sup>				LPG G31 Hi = 25,89 kWh/m <sup>3</sup>	
	d1"1/2-Rp2"	d2"-Rp2"	d65-DN65	s65-DN65	d1"1/2-Rp2"	d2"-Rp2"	d65-DN65	s65-DN65	d1"1/2-Rp2"	d2"-Rp2"
1100	28	15	12	11	39	21	15	15	13	9
1300	39	21	16	16	54	29	21	22	18	11
1500	51	27	21	21	71	37	28	29	23	14
1700	64	34	27	27	91	47	36	37	29	17
1900	80	41	34	34	114	59	45	46	36	20

**Natural gas G20**

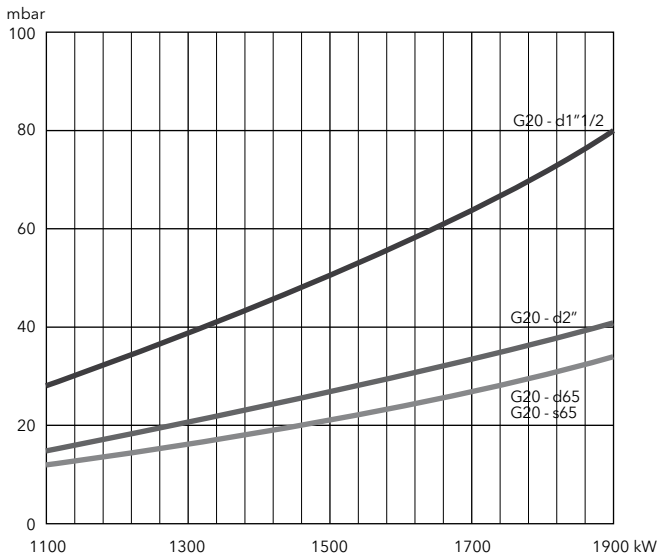

**Natural gas G25**

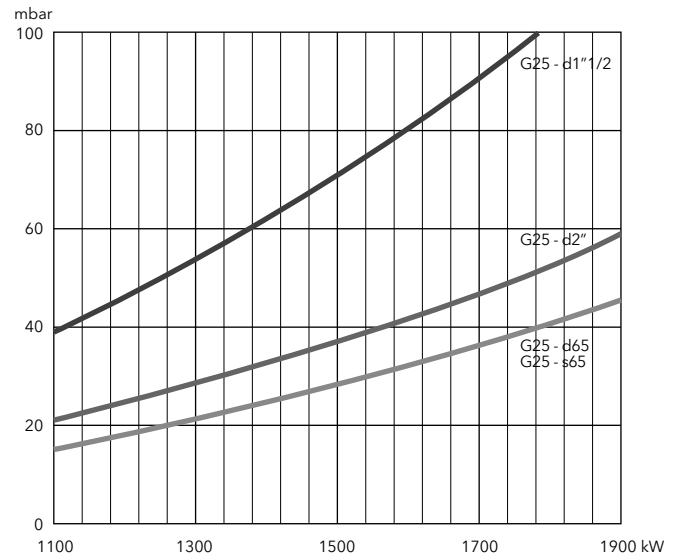

**LPG**

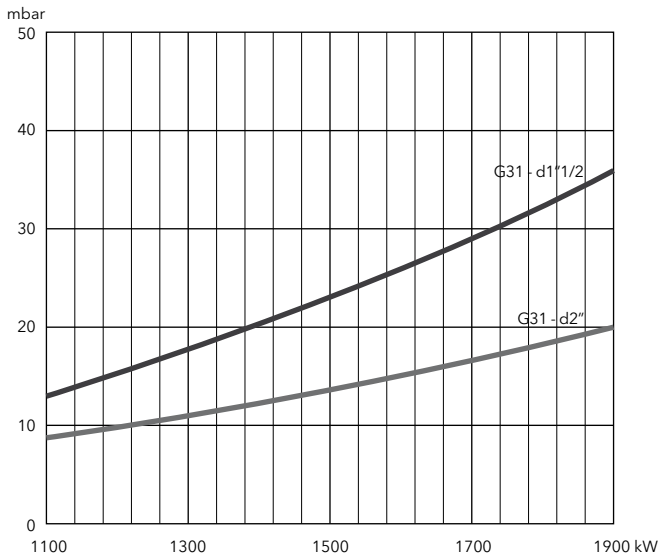

**VG5.950 M R, VG5.1200 M R**

150 ... 1200 kW

2 stage progressive/modulating electronic

- **Fuels:** natural gas (G20/G25,  $H_u = 8,83...10,35 \text{ kWh/m}^3$ ); LPG (G31,  $H_u = 25,89 \text{ kWh/m}^3$ )
- **Emissions:** Low NOx class 2 ( $\leq 120 \text{ mg/kWh}$ ) according to EN676
- **Operation:** two stage progressive or modulating with the installation of a power regulator and dedicated probes (see pag. 180)
- **Protection level:** IP 21



**TECHNICAL DATA**

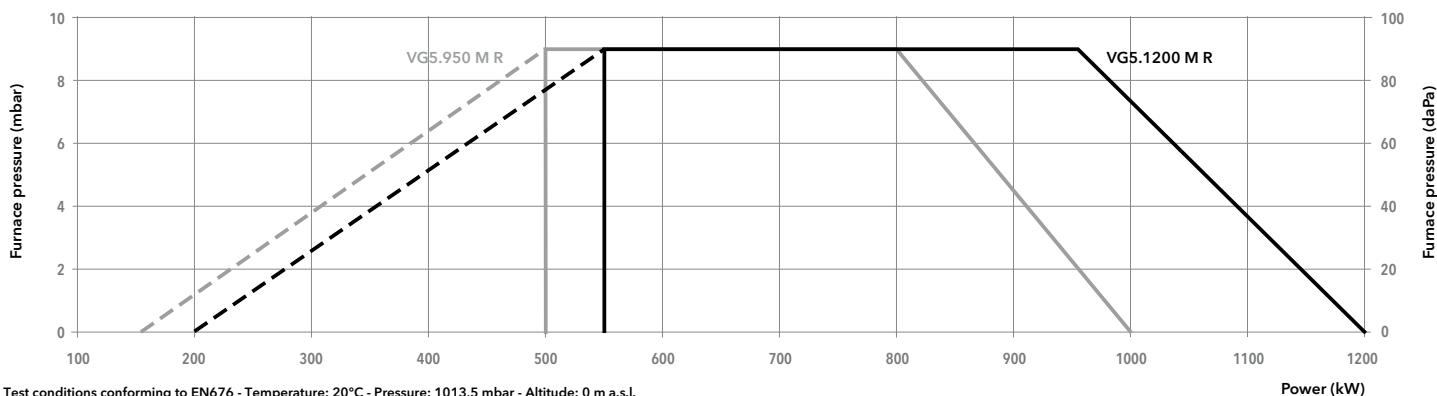

Test conditions conforming to EN676 - Temperature: 20°C - Pressure: 1013,5 mbar - Altitude: 0 m a.s.l.

Model	VG5.950 M R /TC			VG5.1200 M R /TC			
Operation range	(150) 500 - 1000 kW			(200) 550 - 1200 kW			
Gas pressure	50 - 500 mbar			50 - 500 mbar			
Control box / flame detection	BT3... / ionization			BT3... / ionization			
Fan motor	230/400 V - 50 Hz - 1,5 kW			230/400 V - 50 Hz - 1,5 kW			
Electrical consumption	100 + 2200 W			100 + 2300 W			
Acoustic level (LpA)	77 dB(A)			77 dB(A)			
CE certificate	0085 CQ 0570			0085 CQ 0570			
Head lenght	KN	KL	KM	KN	KL	KM	
Complete burner code	VGD 40-065 s65-DN65/TC	3835413	3835414	3835415	3835428	3835429	3835430
	MBC1900 d65-DN65/TC	3835416	3835417	3835418	3835431	3835432	3835433
	MBC1200 d2"-Rp2"/TC	3835419	3835420	3835421	3835434	3835435	3835436
	MBC700 d1"1/2-Rp2"/TC	3835422	3835423	3835424	3835437	3835438	3835439
	MBC300 d3/4"-Rp1"1/4/TC	3835425	3835426	3835427	3835440	3835441	3835442

**OTHER AVAILABLE VERSIONS**

- Vent** Versions for continuous ventilation and post-ventilation
- PED** PED version for continuous operation

**SCOPE OF SUPPLY**

The burner is delivered in its package complete with:

- 1 burner head with flange seal and securing screws
- 1 compact gas train with gas filter; the gas filter is built-in for threaded valves (up to 2") and separated for flanged ones (DN65/80/100)
- 1 bag containing installation fittings
- 1 bag containing technical documentation (instruction manual, technical data, electrical diagram, exploded view and spare parts list)





**DIMENSIONS (mm)**

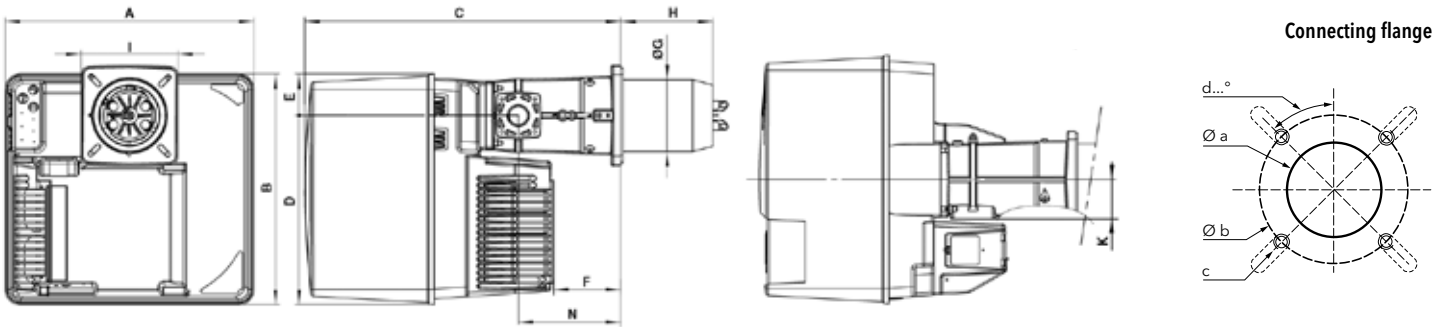

A	B	C	D	E	F	ØG	H			I	K	N
							KN	KM	KL			
581	549	752	450	99	164	170	215	325	435	230x238	89	244

Øa (mm)	b (mm)	c	d
195	220-260	M10	45°

**Gas trains**

Gas train "d":

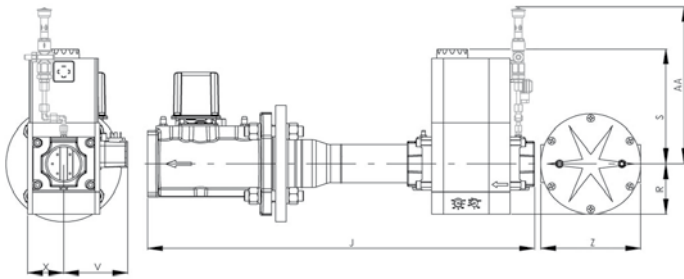

Model	J	R	S	V	X	Z	AA*
d65-DN65	490	183	245	110	98	290	385
d2"-Rp2"	700	96	330	125	81	-	385
d1"1/2-Rp2"	622	80	185	102	57	-	320
d3/4"-Rp1"1/4	460	60	173	88	58	-	320

Gas train "s":

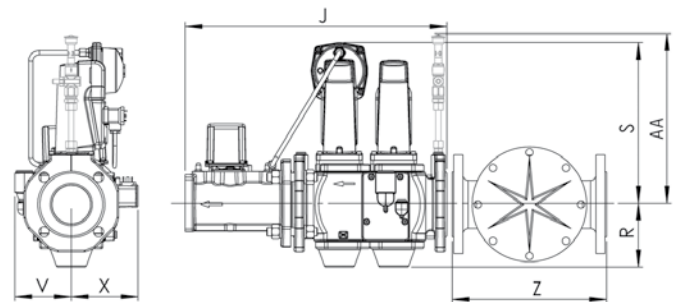

Model	J	R	S	V	X	Z	AA*
s65-DN65	490	118	300	106	126	290	365

\*: for PED configuration

**PACKAGING**

The burner is delivered on a pallet in 3 packages containing:

- burner housing
- combustion head
- gas train and filter

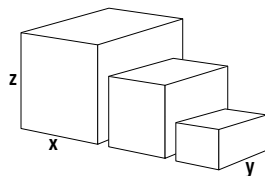

Component		Dimensions (mm)			Gross weight (kg)
		X	Y	Z	
Burner body	VG5.950 M R	800	600	850	53
	VG5.1200 M R	800	600	850	54
Combustion head	KN	780	265	280	12,3
	KL	1010	265	280	14,4
	KM	1010	265	280	13,4
Gas train	s65-DN65/TC	670	550	380	29
	d65-DN65/TC	670	550	380	17,2
	d2"-Rp2"/TC	670	550	380	12
	d1"1/2-Rp2"/TC	670	550	380	12
	d3/4"-Rp1"1/4/TC	590	390	180	7

**VG5.950 M R, VG5.1200 M R**

150 ... 1200 kW

2 stage progressive/modulating electronic

**PRESSURE LOSS [BURNER HEAD + GAS TRAIN] (mbar)**

**VG5.950 M R**

Burner output (kW)	Natural gas G20 Hi = 10,35 kWh/m <sup>3</sup>					Natural gas G25 Hi = 8,83 kWh/m <sup>3</sup>					LPG G31	
	d3/4-Rp1"1/4	d1"1/2-Rp2"	d2"-Rp2"	d65-DN65	s65-DN65	d3/4-Rp1"1/4	d1"1/2-Rp2"	d2"-Rp2"	d65-DN65	s65-DN65	d1"1/2-Rp2"	d3/4-Rp1"1/4
500	31	10	7	6	6	46	15	11	9	9	17	8
600	45	15	9	9	9	67	22	16	12	13	24	11
700	61	20	13	12	12	91	30	22	17	18	32	15
800	79	26	17	15	15	118	39	28	22	23	42	20
900	124	33	21	19	19	149	49	35	28	29	53	25
1000	-	40	26	24	24	185	60	43	34	36	66	31

**Natural gas G20**

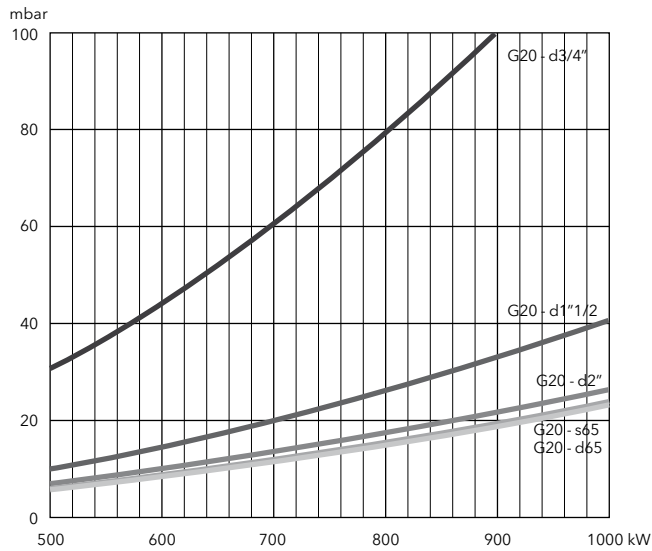

**Natural gas G25**

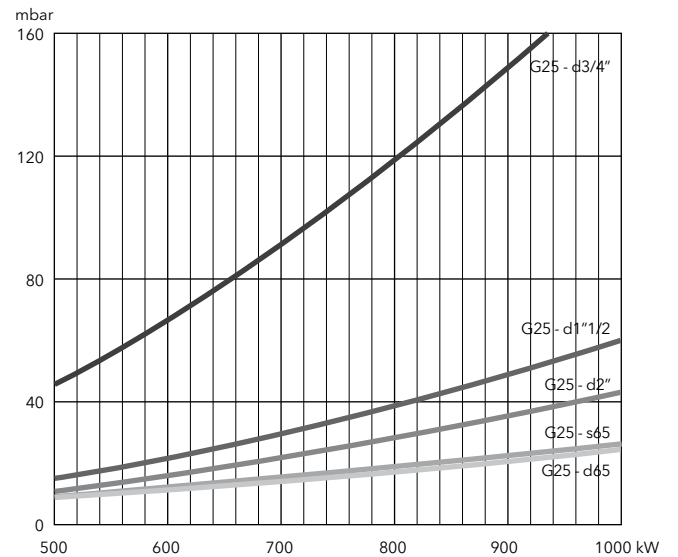

**LPG**

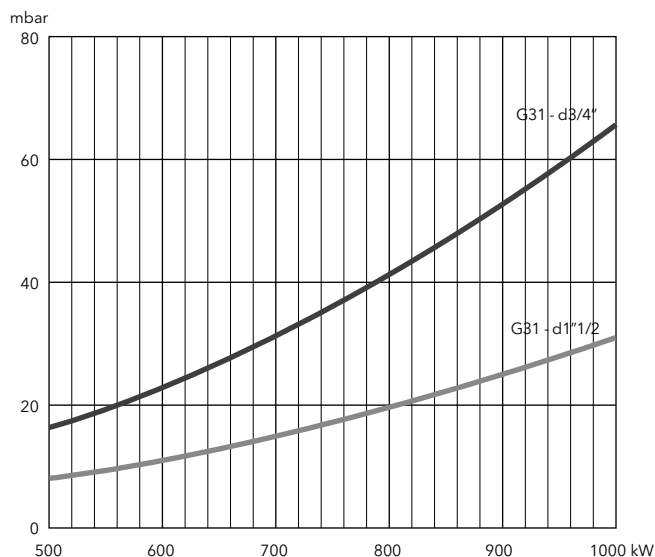



**PRESSURE LOSS [BURNER HEAD + GAS TRAIN] (mbar)**

**VG5.1200 M R**

Burner output (kW)	Natural gas G20 Hi = 10,35 kWh/m <sup>3</sup>					Natural gas G25 Hi = 8,83 kWh/m <sup>3</sup>					LPG G31
	d3/4-Rp1"1/4	d1"1/2-Rp2"	d2"-Rp2"	d65-DN65	s65-DN65	d3/4-Rp1"1/4	d1"1/2-Rp2"	d2"-Rp2"	d65-DN65	s65-DN65	d1"1/2-Rp2"
700	58	17	10	8	9	86	25	14	12	13	10
800	75	22	13	10	11	112	32	19	16	17	14
900	95	27	16	13	14	142	41	24	20	21	17
1000	117	34	20	16	17	175	51	29	24	26	21
1100	142	41	24	20	21	213	62	36	30	32	26
1200	169	49	28	24	25	252	73	42	35	37	31

**Natural gas G20**

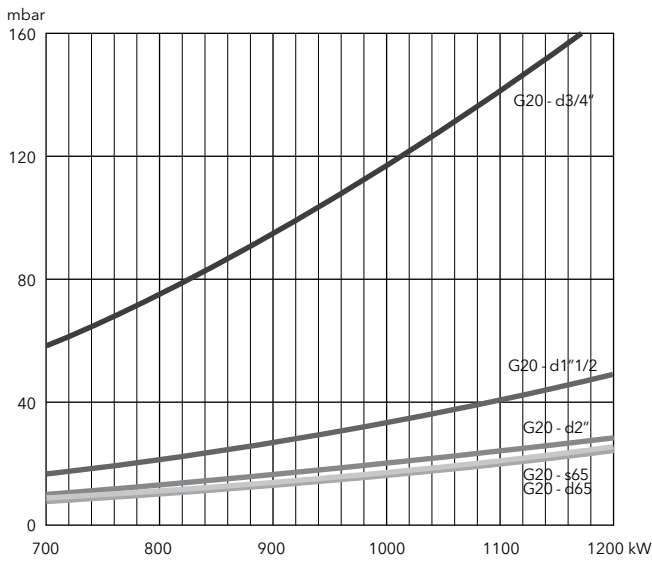

**Natural gas G25**

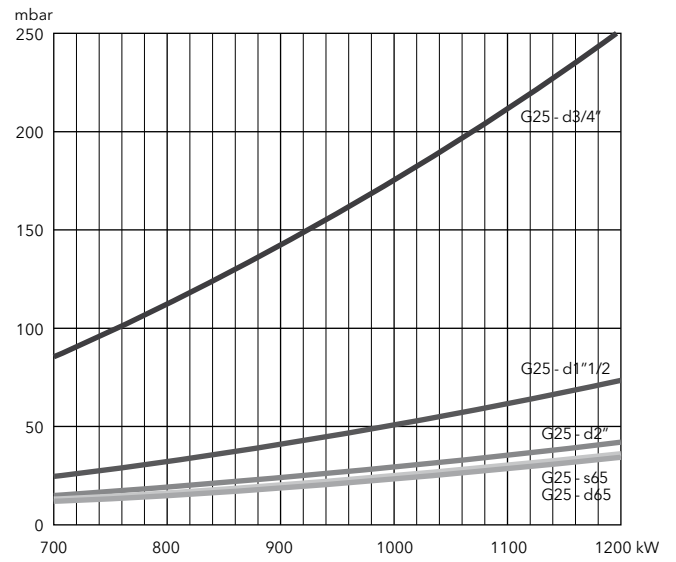

**LPG**

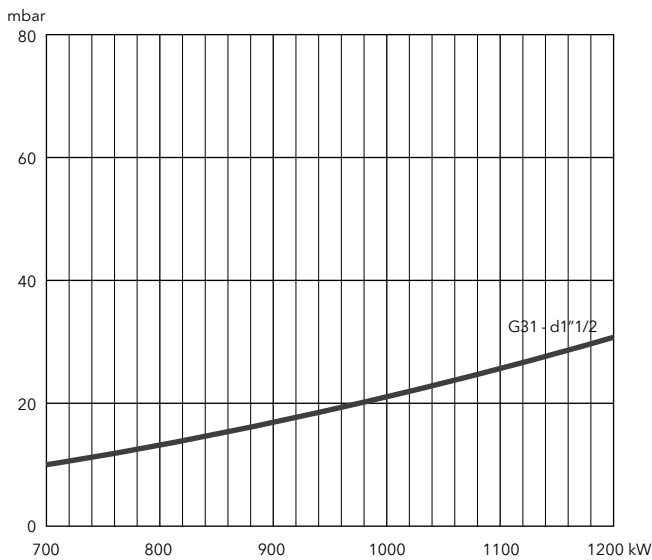

**VG6.1600 M R, VG6.2100 M R**

200 ... 2300 kW

2 stage progressive/modulating electronic

- **Fuels:** natural gas (G20/G25,  $H_u = 8,83...10,35 \text{ kWh/m}^3$ ); LPG (G31,  $H_u = 25,89 \text{ kWh/m}^3$ )
- **Emissions:** Low NOx class 2 ( $\leq 120 \text{ mg/kWh}$ ) according to EN676
- **Operation:** two stage progressive or modulating with the installation of a power regulator and dedicated probes (see pag. 180)
- **Protection level:** IP 21



**TECHNICAL DATA**

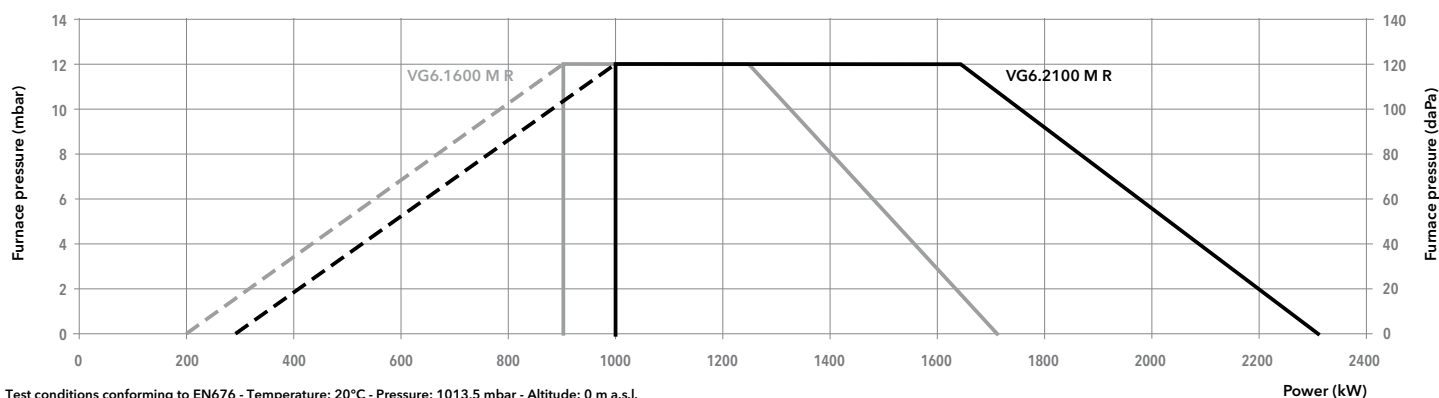

Model	VG6.1600 M R /TC			VG6.2100 M R /TC			
Operation range	(200) 900 - 1700 kW			(300) 1000- 2300 kW			
Gas pressure	50 - 500 mbar			50 - 500 mbar			
Control box / flame detection	BT3... / ionization			BT3... / ionization			
Fan motor	230/400 V - 50 Hz - 2,2 kW			230/400 V - 50 Hz - 2,7 kW			
Electrical consumption	100 + 2500 W			100 + 3500 W			
Acoustic level (LpA)	77 dB(A)			79 dB(A)			
CE certificate	0085 CQ 0570			0085 CQ 0570			
Head lenght	KN	KL	KM	KN	KL	KM	
Complete	VGD 40-065 s65-DN65/TC	3834834	3834835	3834836	3834846	3834847	3834848
burner code	MBC1900 d65-DN65/TC	3834831	3834832	3834833	3834843	3834844	3834845
	MBC1200 d2"-Rp2"/TC	3834828	3834829	3834830	3834840	3834841	3834842
	MBC700 d1"1/2-Rp2"/TC	3834825	3834826	3834827	3834837	3834838	3834839

**OTHER AVAILABLE VERSIONS**

- Vent** Versions for continuous ventilation and post-ventilation
- PED** PED version for continuous operation

**SCOPE OF SUPPLY**

The burner is delivered in its package complete with:

- 1 burner head with flange seal and securing screws
- 1 compact gas train with gas filter; the gas filter is built-in for threaded valves (up to 2") and separated for flanged ones (DN65/80/100)
- 1 bag containing installation fittings
- 1 bag containing technical documentation (instruction manual, technical data, electrical diagram, exploded view and spare parts list)

**DIMENSIONS (mm)**

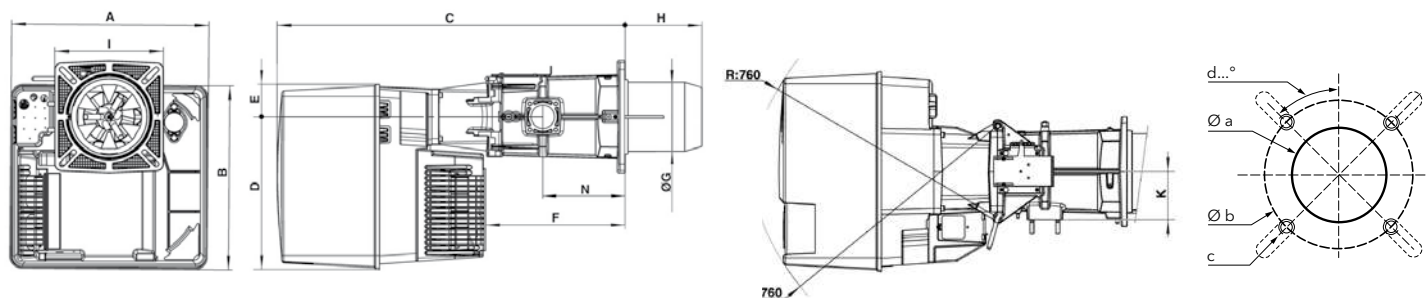

A	B	C	D	E	F	ØG	H			I	K	N
							KN	KM	KL			
592	553	1050	456	97	421	227	270	370	470	326x335	144	247

Øa (mm)	b (mm)	c	d
250	300-400	M12	45°

**Gas trains**

Gas train "d":

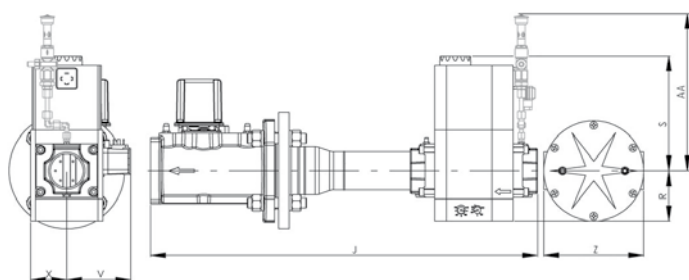

Model	J	R	S	V	X	Z	AA*
d65-DN65	490	183	245	110	98	290	385
d2"-Rp2"	700	96	330	125	81	-	385
d1"1/2-Rp2"	622	80	185	102	57	-	320

Gas train "s":

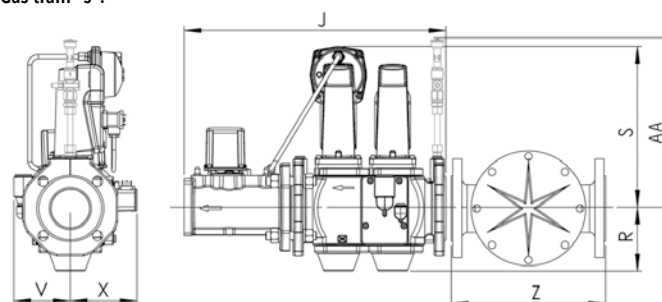

Model	J	R	S	V	X	Z	AA*
s65-DN65	490	118	300	106	126	290	365

\*: for PED configuration

**PACKAGING**

The burner is delivered on a pallet in 3 packages containing:

- burner housing
- combustion head
- gas train and filter

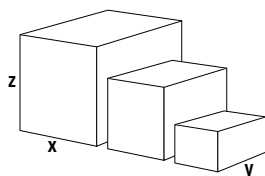

Component		Dimensions (mm)			Gross weight (kg)
		X	Y	Z	
Burner body	VG6.1600 M R	800	600	850	67,8
	VG6.2100 M R	800	600	850	69,2
Combustion head	KN	1000	380	420	26,7
	KL	1100	380	430	29,4
	KM	1100	380	430	28
Gas train	s65-DN65/TC	670	550	380	29,4
	d65-DN65/TC	670	550	380	33
	d2"-Rp2"/TC	670	550	380	16,5
	d1"1/2-Rp2"/TC	670	550	380	14,3

**VG6.1600 M R, VG6.2100 M R**

200 ... 2300 kW

2 stage progressive/modulating electronic

**PRESSURE LOSS [BURNER HEAD + GAS TRAIN] (mbar)**

**VG6.1600 M R**

Burner output (kW)	Natural gas G20 Hi = 10,35 kWh/m <sup>3</sup>				Natural gas G25 Hi = 8,83 kWh/m <sup>3</sup>				LPG G31
	d1"1/2-Rp2"	d2"-Rp2"	d65-DN65	s65-DN65	d1"1/2-Rp2"	d2"-Rp2"	d65-DN65	s65-DN65	d1"1/2-Rp2"
800	17	7	5	6	25	10	8	9	5
1000	25	11	8	9	37	16	11	13	7
1200	36	16	11	13	54	23	16	19	10
1400	49	21	15	17	73	32	22	25	13
1600	64	28	19	22	96	41	29	33	17

**Natural gas G20**

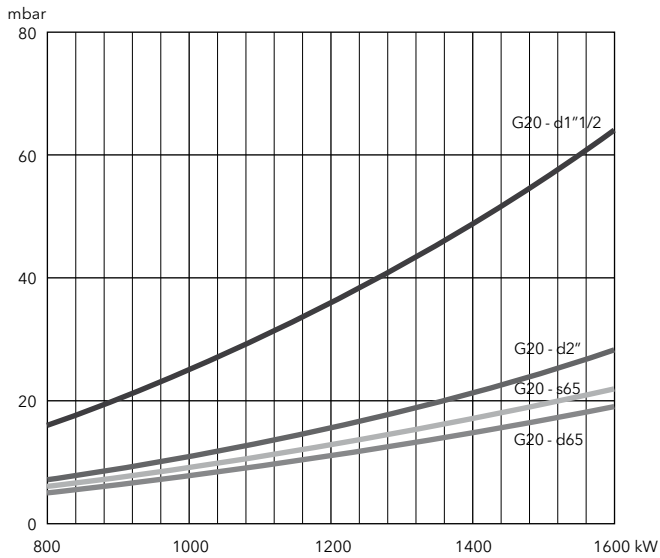

**Natural gas G25**

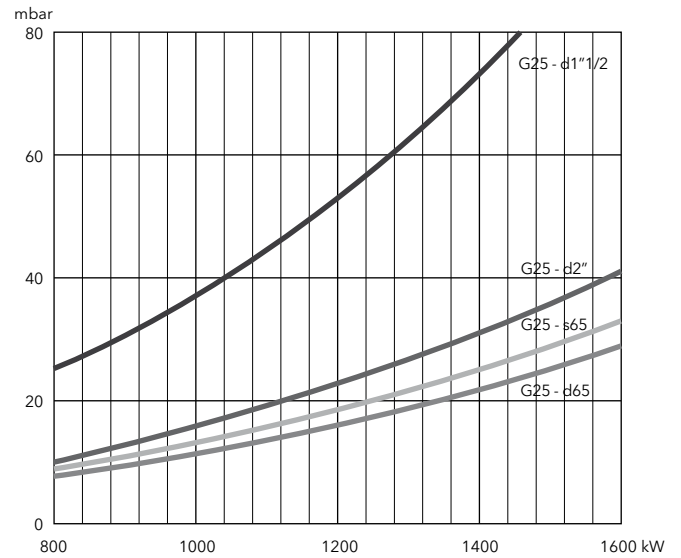

**LPG**

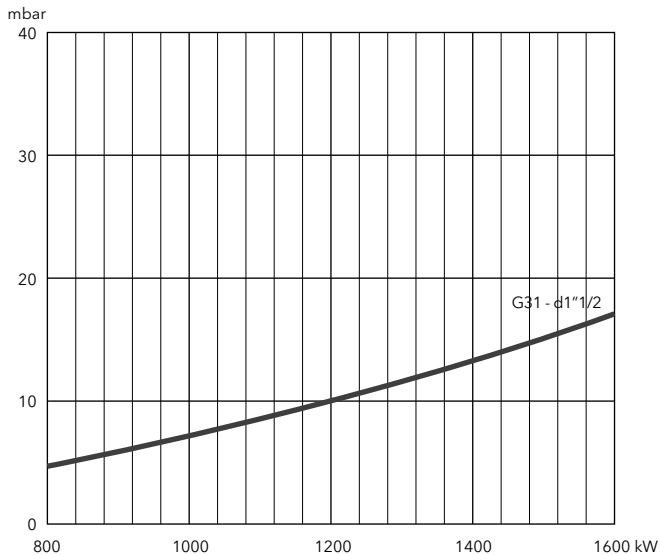



**PRESSURE LOSS [BURNER HEAD + GAS TRAIN] (mbar)**

**VG6.2100 M R**

Burner output (kW)	Natural gas G20 Hi = 10,35 kWh/m <sup>3</sup>				Natural gas G25 Hi = 8,83 kWh/m <sup>3</sup>				LPG G31 Hi = 25,89 kWh/m <sup>3</sup>	
	d1"1/2-Rp2"	d2"-Rp2"	d65-DN65	s65-DN65	d1"1/2-Rp2"	d2"-Rp2"	d65-DN65	s65-DN65	d1"1/2-Rp2"	d2"-Rp2"
1300	40	16	10	12	60	24	15	18	19	9
1500	53	21	13	16	78	31	20	24	25	11
1700	68	27	17	20	102	40	26	30	32	14
1900	85	34	22	26	127	50	32	38	40	18
2100	104	41	27	31	156	61	40	46	48	22
2300	125	49	32	37	186	73	48	56	58	27

**Natural gas G20**

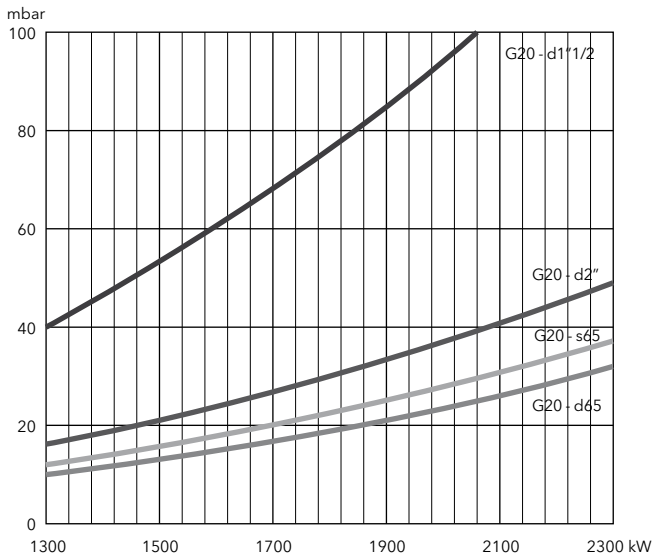

**Natural gas G25**

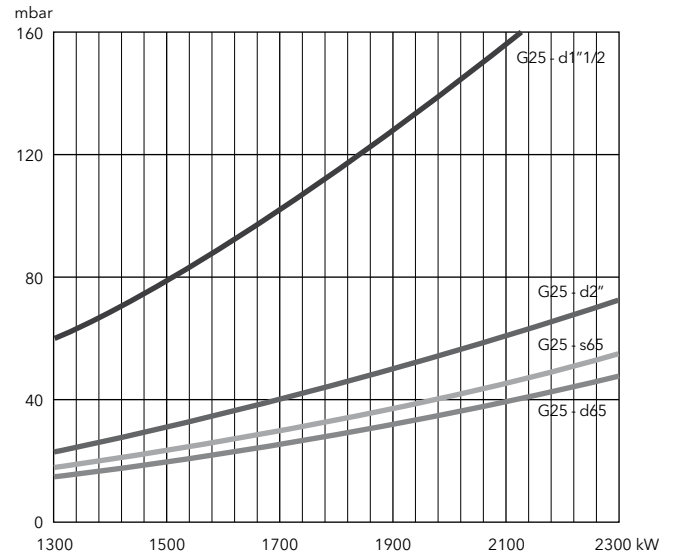

**LPG**

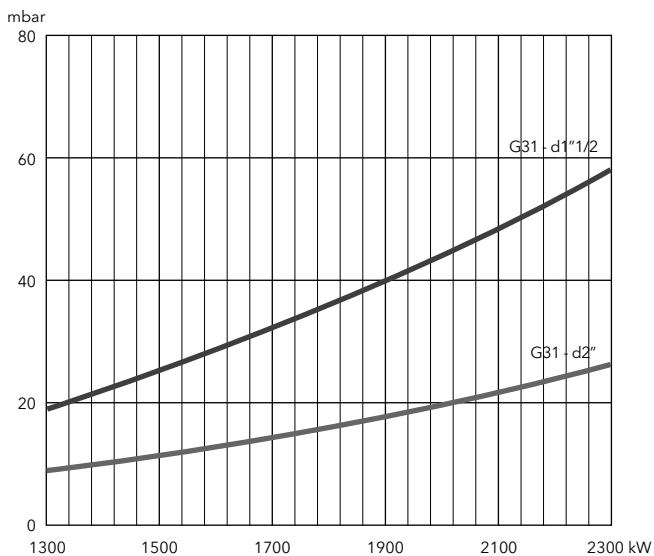

**VG5.950 M V R, VG5.1200 M V R**

150 ... 1200 kW  
2 stage progressive/modulating electronic + fan speed control



- **Fuels:** natural gas (G20/G25,  $H_u = 8,83...10,35 \text{ kWh/m}^3$ ); LPG (G31,  $H_u = 25,89 \text{ kWh/m}^3$ )
- **Emissions:** Low NOx class 2 ( $\leq 120 \text{ mg/kWh}$ ) according to EN676
- **Operation:** two stage progressive or modulating with the installation of a power regulator and dedicated probes (see pag. 180)
- **Protection level:** IP 21

**TECHNICAL DATA**

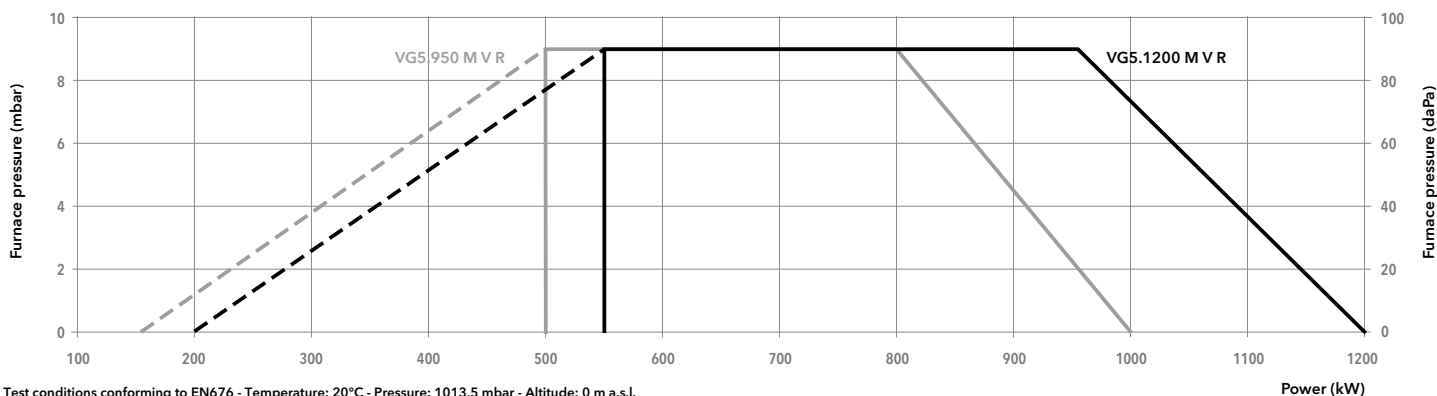

Test conditions conforming to EN676 - Temperature: 20°C - Pressure: 1013,5 mbar - Altitude: 0 m a.s.l.

Model	VG5.950 M V R /TC			VG5.1200 M V R /TC			
Operation range	(150) 500 - 1000 kW			(200) 550 - 1200 kW			
Gas pressure	50 - 500 mbar			50 - 500 mbar			
Control box / flame detection	BT3... / ionization			BT3... / ionization			
Fan motor	230/400 V - 50 Hz - 1,5 kW			230/400 V - 50 Hz - 1,5 kW			
Electrical consumption	100 + 2200 W			100 + 2300 W			
Acoustic level (LpA)	77 dB(A)			77 dB(A)			
CE certificate	0085 CQ 0570			0085 CQ 0570			
Head lenght	KN	KL	KM	KN	KL	KM	
Complete burner code	VGD 40-065 s65-DN65/TC	3835443	3835444	3835445	3835458	3835459	3835460
	MBC1900 d65-DN65/TC	3835446	3835447	3835448	3835461	3835462	3835463
	MBC1200 d2"-Rp2"/TC	3835449	3835450	3835451	3835464	3835465	3835466
	MBC700 d1"1/2-Rp2"/TC	3835452	3835453	3835454	3835467	3835468	3835469
	MBC300 d3/4"-Rp1"1/4/TC	3835455	3835456	3835457	3835470	3835471	3835472

**OTHER AVAILABLE VERSIONS**

- Vent** Versions for continuous ventilation and post-ventilation
- PED** PED version for continuous operation

**SCOPE OF SUPPLY**

- The burner is delivered in its package complete with:
- 1 burner head with flange seal and securing screws
  - 1 compact gas train with gas filter; the gas filter is built-in for threaded valves (up to 2") and separated for flanged ones (DN65/80/100)
  - 1 bag containing installation fittings
  - 1 bag containing technical documentation (instruction manual, technical data, electrical diagram, exploded view and spare parts list)





**DIMENSIONS (mm)**

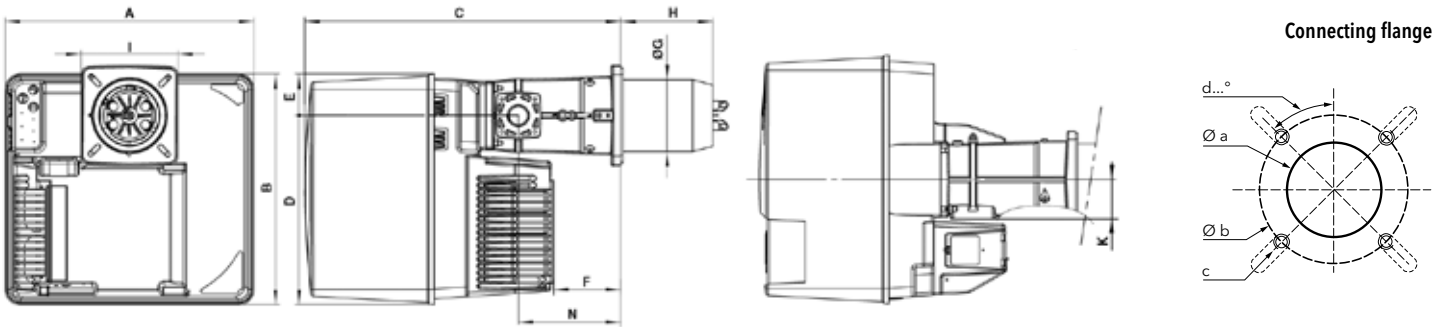

A	B	C	D	E	F	ØG	H			I	K	N
							KN	KM	KL			
581	549	752	450	99	164	170	215	325	435	230x238	89	244

Øa (mm)	b (mm)	c	d
195	220-260	M10	45°

**Gas trains**

Gas train "d":

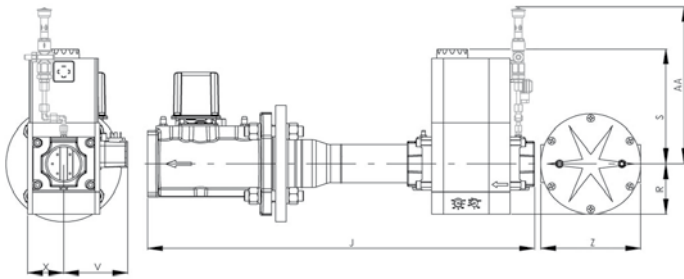

Model	J	R	S	V	X	Z	AA*
d65-DN65	490	183	245	110	98	290	385
d2"-Rp2"	700	96	330	125	81	-	385
d1"1/2-Rp2"	622	80	185	102	57	-	320
d3/4"-Rp1"1/4	460	60	173	88	58	-	320

Gas train "s":

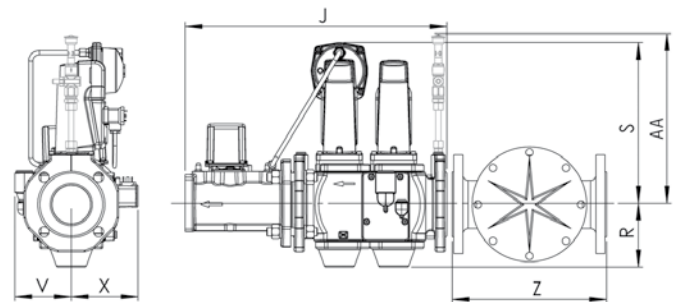

Model	J	R	S	V	X	Z	AA*
s65-DN65	490	118	300	106	126	290	365

\*: for PED configuration

**PACKAGING**

The burner is delivered on a pallet in 3 packages containing:

- burner housing
- combustion head
- gas train and filter

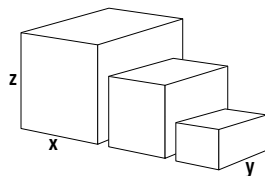

Component		Dimensions (mm)			Gross weight (kg)
		X	Y	Z	
Burner body	VG5.950 M V R	800	600	850	53
	VG5.1200 M V R	800	600	850	54
Combustion head	KN	780	265	280	12,3
	KL	1010	265	280	14,4
	KM	1010	265	280	13,4
Gas train	s65-DN65/TC	670	550	380	29
	d65-DN65/TC	670	550	380	17,2
	d2"-Rp2"/TC	670	550	380	12
	d1"1/2-Rp2"/TC	670	550	380	12
	d3/4"-Rp1"1/4/TC	590	390	180	7

**VG5.950 M V R, VG5.1200 M V R**

150 ... 1200 kW  
2 stage progressive/modulating electronic + fan speed control

**PRESSURE LOSS [BURNER HEAD + GAS TRAIN] (mbar)**

**VG5.950 M V R**

Burner output (kW)	Natural gas G20 Hi = 10,35 kWh/m <sup>3</sup>					Natural gas G25 Hi = 8,83 kWh/m <sup>3</sup>					LPG G31	
	d3/4-Rp1"1/4	d1"1/2-Rp2"	d2"-Rp2"	d65-DN65	s65-DN65	d3/4-Rp1"1/4	d1"1/2-Rp2"	d2"-Rp2"	d65-DN65	s65-DN65	d1"1/2-Rp2"	d3/4-Rp1"1/4
500	31	10	7	6	6	46	15	11	9	9	17	8
600	45	15	9	9	9	67	22	16	12	13	24	11
700	61	20	13	12	12	91	30	22	17	18	32	15
800	79	26	17	15	15	118	39	28	22	23	42	20
900	124	33	21	19	19	149	49	35	28	29	53	25
1000	-	40	26	24	24	185	60	43	34	36	66	31

**Natural gas G20**

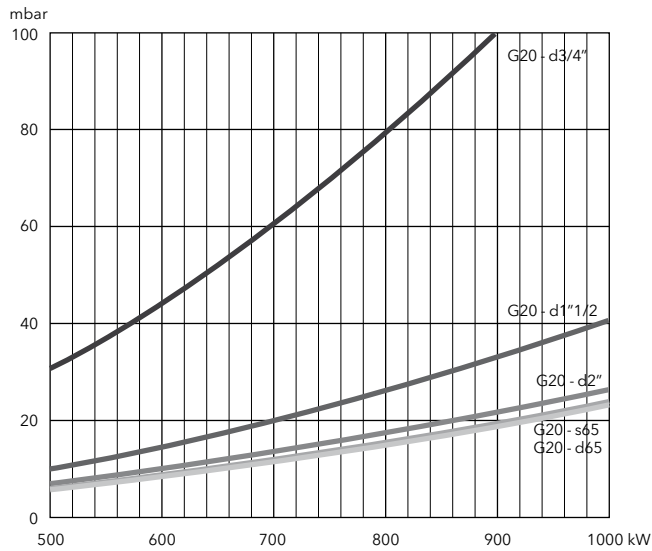

**Natural gas G25**

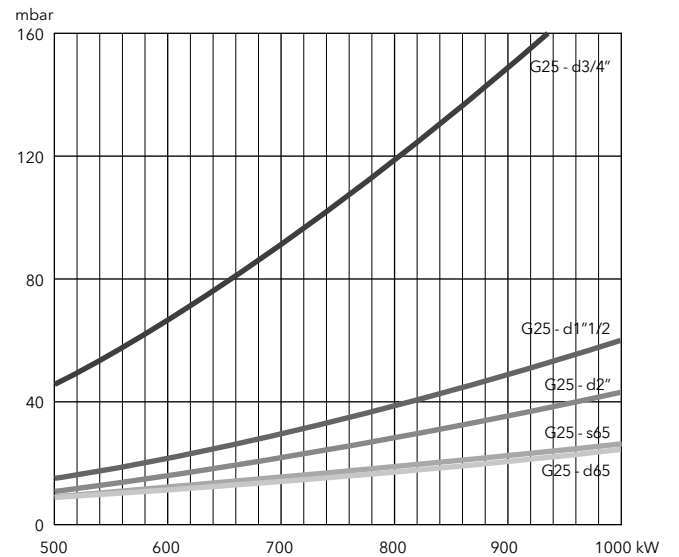

**LPG**

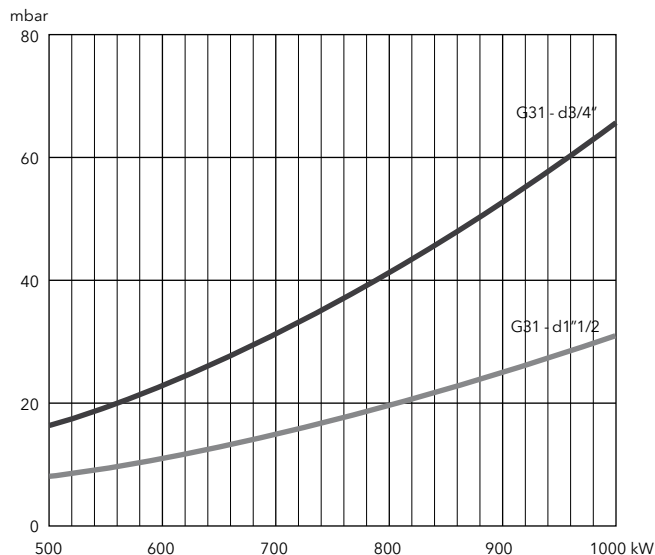



**PRESSURE LOSS [BURNER HEAD + GAS TRAIN] (mbar)**

**VG5.1200 M V R**

Burner output (kW)	Natural gas G20 Hi = 10,35 kWh/m <sup>3</sup>					Natural gas G25 Hi = 8,83 kWh/m <sup>3</sup>					LPG G31
	d3/4-Rp1"1/4	d1"1/2-Rp2"	d2"-Rp2"	d65-DN65	s65-DN65	d3/4-Rp1"1/4	d1"1/2-Rp2"	d2"-Rp2"	d65-DN65	s65-DN65	d1"1/2-Rp2"
700	58	17	10	8	9	86	25	14	12	13	10
800	75	22	13	10	11	112	32	19	16	17	14
900	95	27	16	13	14	142	41	24	20	21	17
1000	117	34	20	16	17	175	51	29	24	26	21
1100	142	41	24	20	21	213	62	36	30	32	26
1200	169	49	28	24	25	252	73	42	35	37	31

**Natural gas G20**

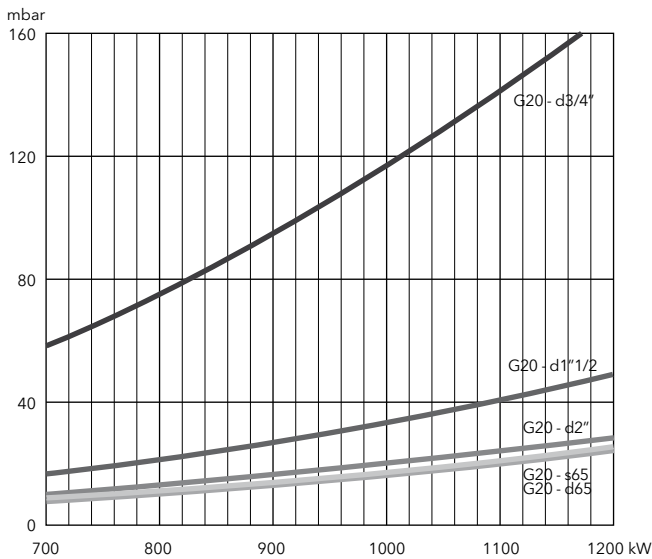

**Natural gas G25**

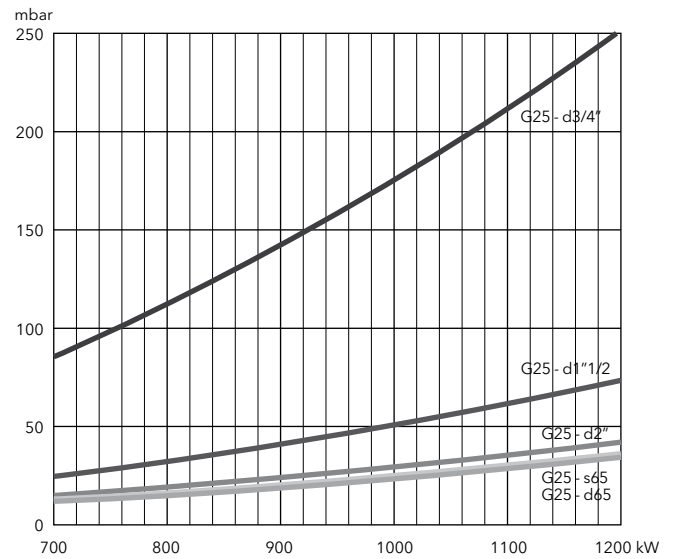

**LPG**

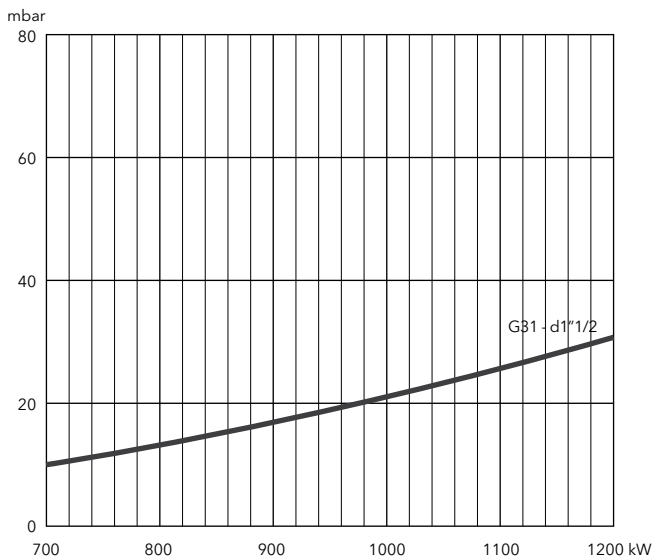

**VG6.1600 M V R, VG6.2100 M V R**

200 ... 2300 kW  
2 stage progressive/modulating electronic + fan speed control

- **Fuels:** natural gas (G20/G25,  $H_u = 8,83...10,35 \text{ kWh/m}^3$ ); LPG (G31,  $H_u = 25,89 \text{ kWh/m}^3$ )
- **Emissions:** Low NOx class 2 ( $\leq 120 \text{ mg/kWh}$ ) according to EN676
- **Operation:** two stage progressive or modulating with the installation of a power regulator and dedicated probes (see pag. 180)
- **Protection level:** IP 21



**TECHNICAL DATA**

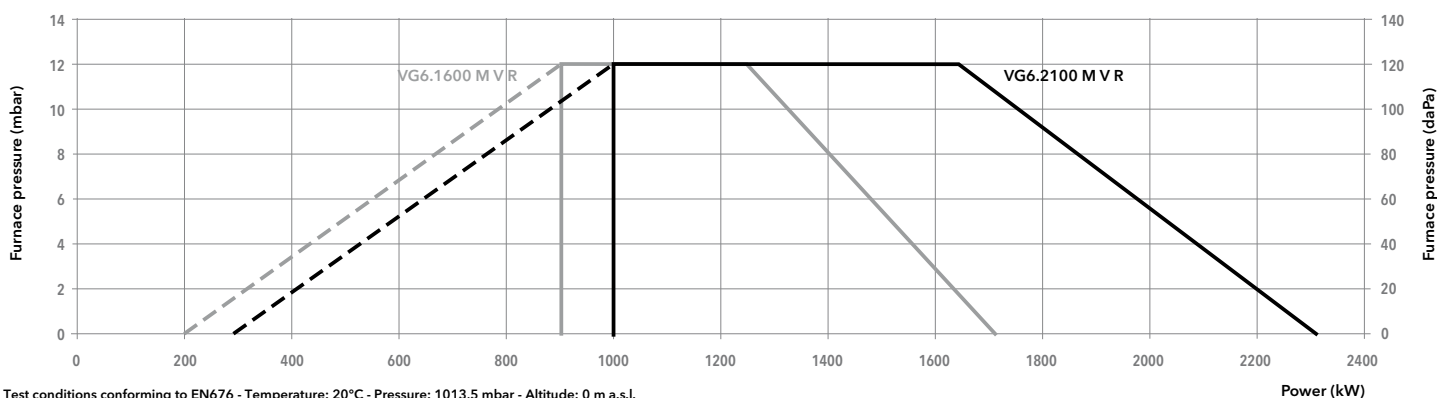

Model	VG6.1600 M V R /TC			VG6.2100 M V R /TC			
Operation range	(200) 900 - 1700 kW			(300) 1000 - 2300 kW			
Gas pressure	50 - 500 mbar			50 - 500 mbar			
Control box / flame detection	BT3... / ionization			BT3... / ionization			
Fan motor	230/400 V - 50 Hz - 2,2 kW			230/400 V - 50 Hz - 2,7 kW			
Electrical consumption	100 + 2500 W			100 + 3500 W			
Acoustic level (LpA)	77 dB(A)			79 dB(A)			
CE certificate	0085 CQ 0570			0085 CQ 0570			
Head lenght	KN	KM	KL	KN	KM	KL	
Complete	VGD 40-065 s65-DN65/TC	3835473	3835475	3835474	3835485	3835487	3835486
burner code	MBC1900 d65-DN65/TC	3835476	3835478	3835477	3835488	3835490	3835489
	MBC1200 d2"-Rp2"/TC	3835479	3835481	3835480	3835491	3835493	3835492
	MBC700 d1"1/2-Rp2"/TC	3835482	3835484	3835483	3835494	3835496	3835495

**OTHER AVAILABLE VERSIONS**

- Vent** Versions for continuous ventilation and post-ventilation
- PED** PED version for continuous operation

**SCOPE OF SUPPLY**

The burner is delivered in its package complete with:

- 1 burner head with flange seal and securing screws
- 1 compact gas train with gas filter; the gas filter is built-in for threaded valves (up to 2") and separated for flanged ones (DN65/80/100)
- 1 bag containing installation fittings
- 1 bag containing technical documentation (instruction manual, technical data, electrical diagram, exploded view and spare parts list)



**DIMENSIONS (mm)**

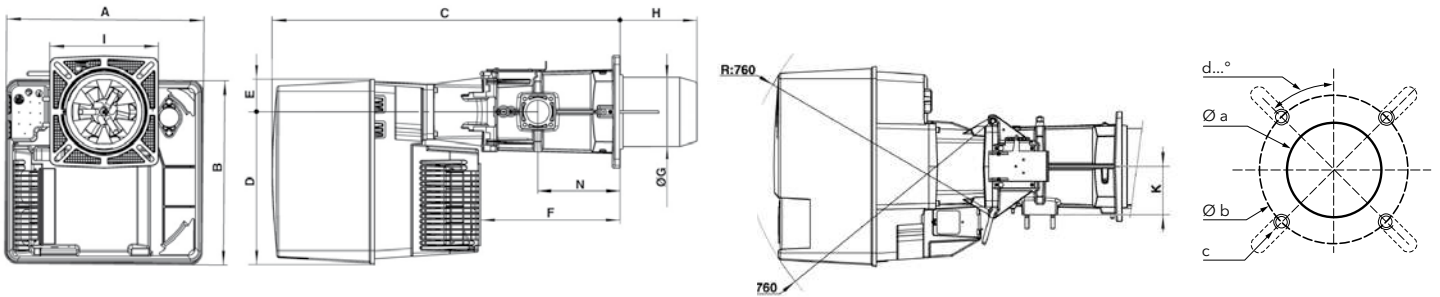

A	B	C	D	E	F	ØG	H			I	K	N
							KN	KM	KL			
592	553	1050	456	97	421	227	270	370	470	326x335	144	247

Øa (mm)	b (mm)	c	d
250	300-400	M12	45°

**Gas trains**

Gas train "d":

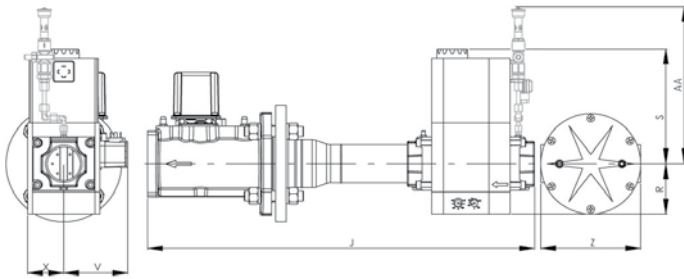

Model	J	R	S	V	X	Z	AA*
d65-DN65	490	183	245	110	98	290	385
d2"-Rp2"	700	96	330	125	81	-	385
d1"1/2-Rp2"	622	80	185	102	57	-	320

Gas train "s":

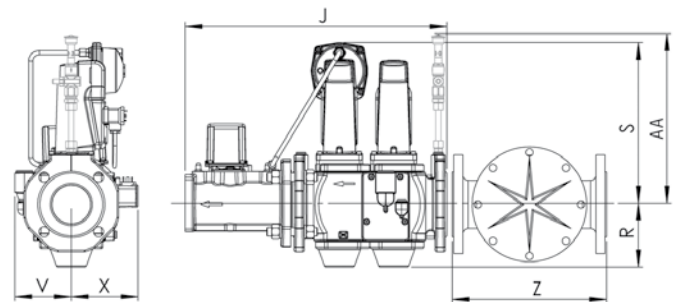

Model	J	R	S	V	X	Z	AA*
s65-DN65	490	118	300	106	126	290	365

\*: for PED configuration

**PACKAGING**

The burner is delivered on a pallet in 3 packages containing:

- burner housing
- combustion head
- gas train and filter

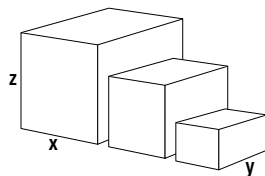

Component		Dimensions (mm)			Gross weight (kg)
		X	Y	Z	
Burner body	VG6.1600 M V R	800	600	850	67,8
	VG6.2100 M V R	800	600	850	69,2
Combustion head	KN	1000	380	420	26,7
	KL	1100	380	430	29,4
	KM	1100	380	430	28
Gas train	s65-DN65/TC	670	550	380	29,4
	d65-DN65/TC	670	550	380	33
	d2"-Rp2"/TC	670	550	380	16,5
	d1"1/2-Rp2"/TC	670	550	380	14,3

**VG6.1600 M V R, VG6.2100 M V R**

200 ... 2300 kW

2 stage progressive/modulating electronic + fan speed control

**PRESSURE LOSS [BURNER HEAD + GAS TRAIN] (mbar)**

**VG6.1600 M V R**

Burner output (kW)	Natural gas G20 Hi = 10,35 kWh/m <sup>3</sup>				Natural gas G25 Hi = 8,83 kWh/m <sup>3</sup>				LPG G31
	d1"1/2-Rp2"	d2"-Rp2"	d65-DN65	s65-DN65	d1"1/2-Rp2"	d2"-Rp2"	d65-DN65	s65-DN65	d1"1/2-Rp2"
800	17	7	5	6	25	10	8	9	5
1000	25	11	8	9	37	16	11	13	7
1200	36	16	11	13	54	23	16	19	10
1400	49	21	15	17	73	32	22	25	13
1600	64	28	19	22	96	41	29	33	17

**Natural gas G20**

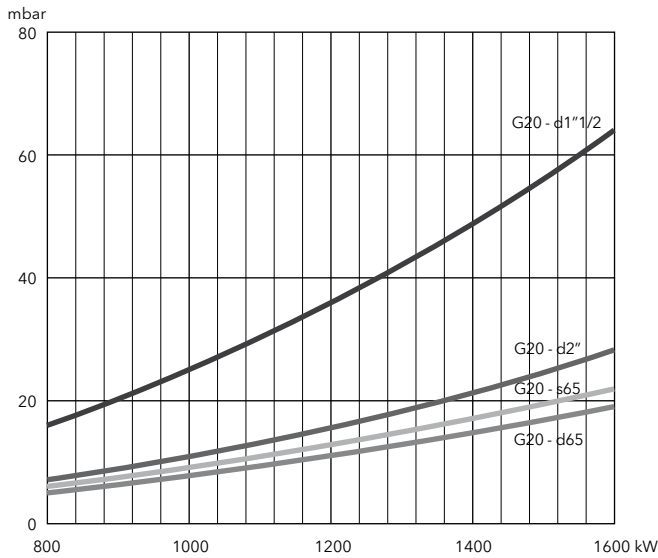

**Natural gas G25**

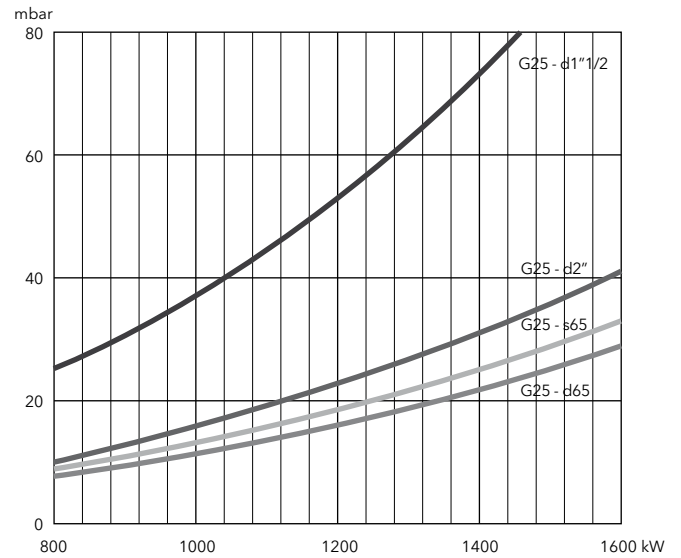

**LPG**

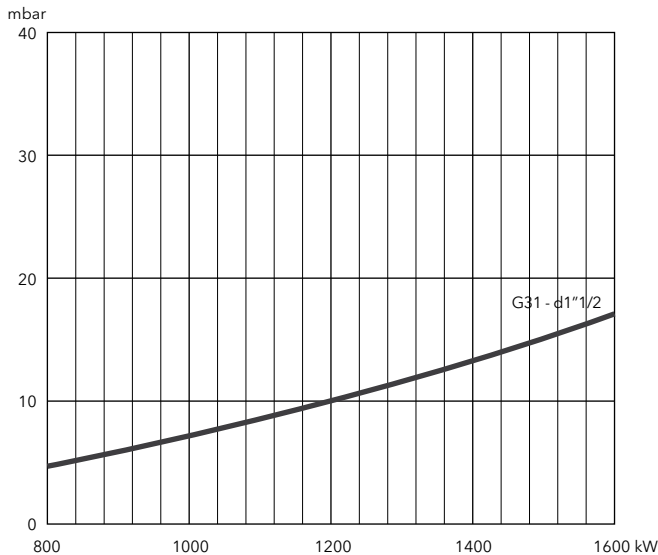



**PRESSURE LOSS [BURNER HEAD + GAS TRAIN] (mbar)**

**VG6.2100 M V R**

Burner output (kW)	Natural gas G20 Hi = 10,35 kWh/m <sup>3</sup>				Natural gas G25 Hi = 8,83 kWh/m <sup>3</sup>				LPG G31 Hi = 25,89 kWh/m <sup>3</sup>	
	d1"1/2-Rp2"	d2"-Rp2"	d65-DN65	s65-DN65	d1"1/2-Rp2"	d2"-Rp2"	d65-DN65	s65-DN65	d1"1/2-Rp2"	d2"-Rp2"
1300	40	16	10	12	60	24	15	18	19	9
1500	53	21	13	16	78	31	20	24	25	11
1700	68	27	17	20	102	40	26	30	32	14
1900	85	34	22	26	127	50	32	38	40	18
2100	104	41	27	31	156	61	40	46	48	22
2300	125	49	32	37	186	73	48	56	58	27

**Natural gas G20**

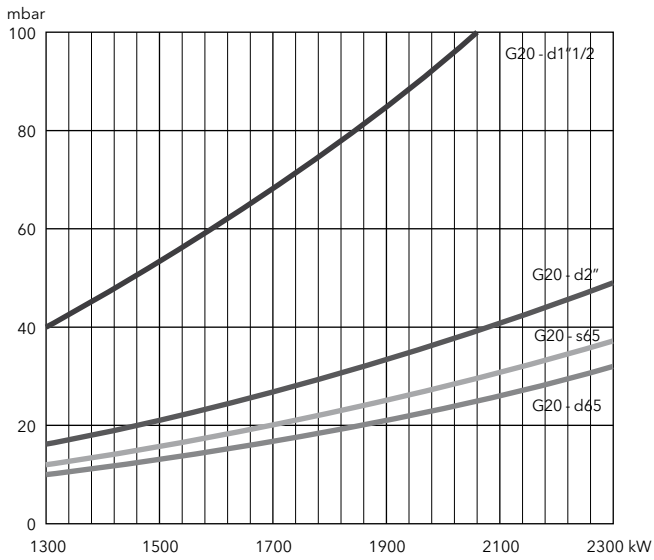

**Natural gas G25**

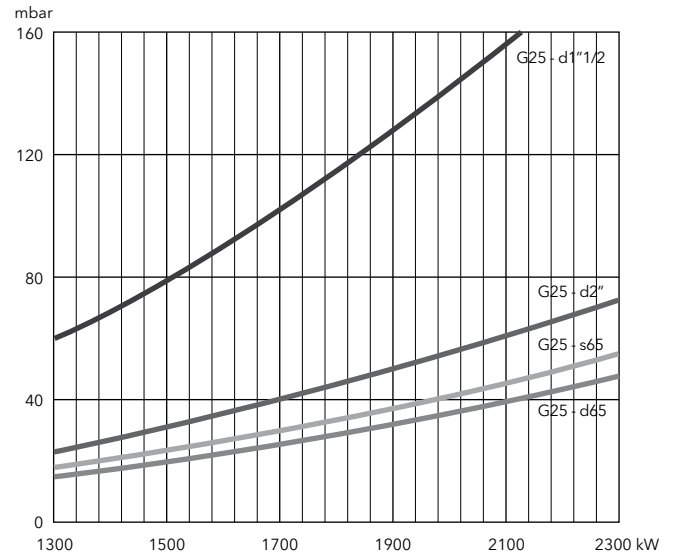

**LPG**

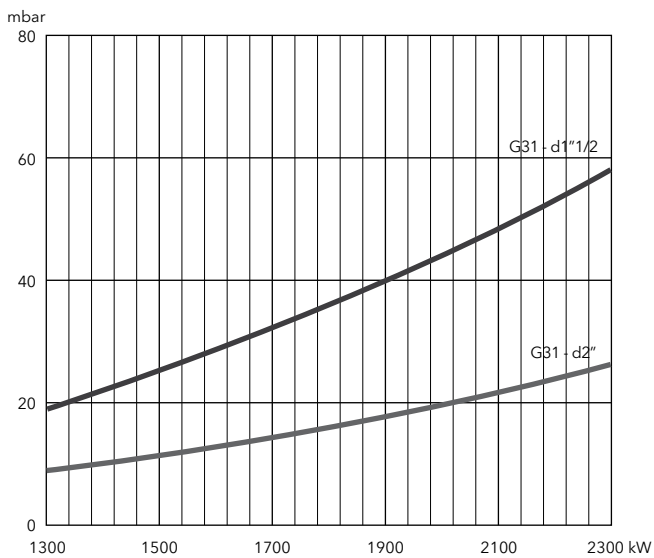

## VGL2.120, VGL2.210

35 ... 190 kW

1 stage in gas / 1 stage in light oil

- **Fuels:** natural gas (G20/G25,  $H_u = 8,83...10,35 \text{ kWh/m}^3$ );  
light oil (viscosity  $6 \text{ mm}^2/\text{s}$  at  $20^\circ\text{C}$ ,  $H_u = 11,86 \text{ kWh/kg}$ )
- **Emissions:** Low NOx class 2 in gas ( $\leq 120 \text{ mg/kWh}$ ) according to EN676  
Low NOx class 2 in light oil ( $\leq 185 \text{ mg/kWh}$ ) according to EN267
- **Protection level:** IP 21



### TECHNICAL DATA

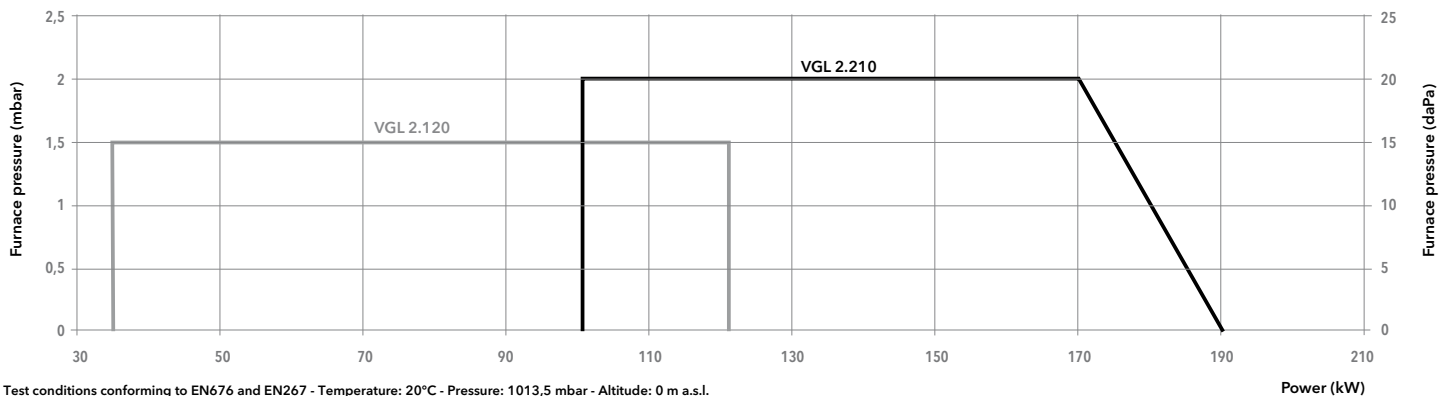

Model	VGL2.120	VGL2.210
Operation range	35 - 120 kW	100 - 190 kW
Gas pressure	20 - 300 mbar	20 - 300 mbar
Control box / flame detection	TCG 1... / IRD 1020	TCG 1... / IRD 1020
Fan motor	230 V - 50 Hz - 160 W	230 V - 50 Hz - 130 W
Nozzle	1,85 US gal/h $45^\circ\text{S}$	2,75 US gal/h $45^\circ\text{B}$
Electrical consumption	186 W	246 W
Acoustic level (LpA)	62 dB(A)	65,2 dB(A)
CE certificate	1312 BU 5219	1312 BU 5219
Head lenght	KL	KL
Complete burner MB-DLE 407 d3/4"-Rp3/4"	<b>3833494</b>	<b>3833495</b>

### OTHER AVAILABLE VERSIONS

 Versions for continuous ventilation and post-ventilation

### SCOPE OF SUPPLY

The burner is delivered in its package complete with:

- 1 gas connection flange
- 1 compact gas train with gas filter; the gas filter is built-in for threaded valves (up to 2") and separated for flanged ones (DN65/80/100)
- 1 burner flange with insulation
- 1 bag containing installation fittings
- 1 bag containing technical documentation (instruction manual, technical data, electrical diagram, exploded view and spare parts list)



DIMENSIONS (mm)

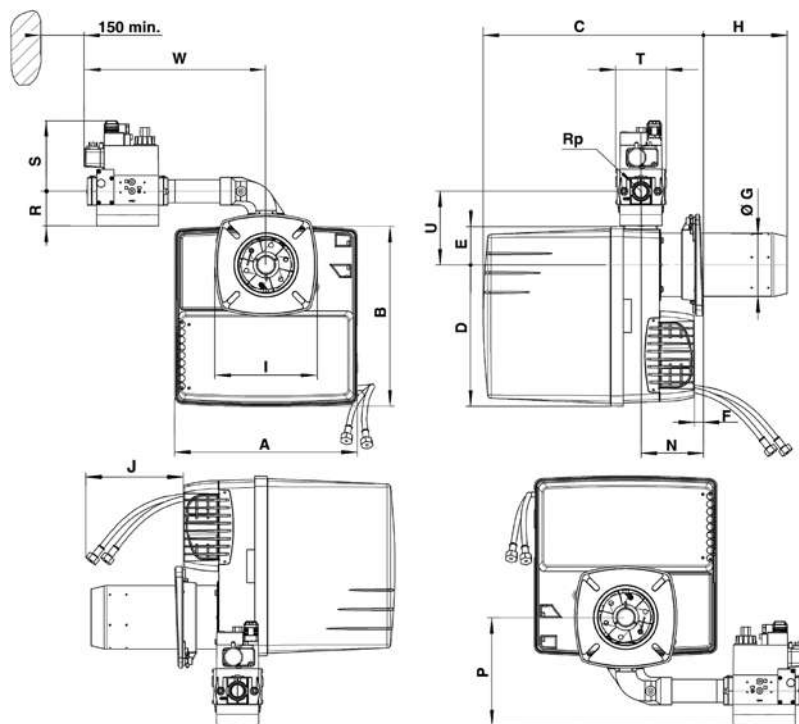

A	B	C	D	E	F min	ØG	H	I	J	N min	P	Rp	R	S	T	U	W
		KL					KL										
331	325	398...638	256	69	15	115	30...270	185	700	113	115	3/4"	46	140	120	133	330

Connecting flange

Øa (mm)	b (mm)	c	d
130-140	172-184	M8	45°

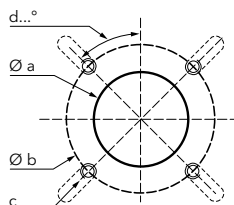

PACKAGING

The burner is delivered in 1 single package containing all components

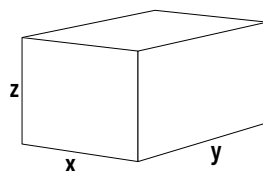

Burner	Dimensions (mm)			Gross weight (kg)
	X	Y	Z	
VGL2.120	400	400	770	23
VGL2.210	400	400	770	24

## VGL3.290 D, VGL3.360 D

95 ... 360 kW

2 stages in gas (Low NOx class 3) / 2 stages in light oil

- **Fuels:** natural gas (G20/G25,  $H_u = 8,83...10,35 \text{ kWh/m}^3$ );  
light oil (viscosity  $6 \text{ mm}^2/\text{s}$  at  $20^\circ\text{C}$ ,  $H_u = 11,86 \text{ kWh/kg}$ )
- **Emissions:** Low NOx class 3 in gas ( $\leq 80 \text{ mg/kWh}$ ) according to EN676  
Low NOx class 2 in light oil ( $\leq 185 \text{ mg/kWh}$ ) according to EN267
- **Protection level:** IP 41



### TECHNICAL DATA

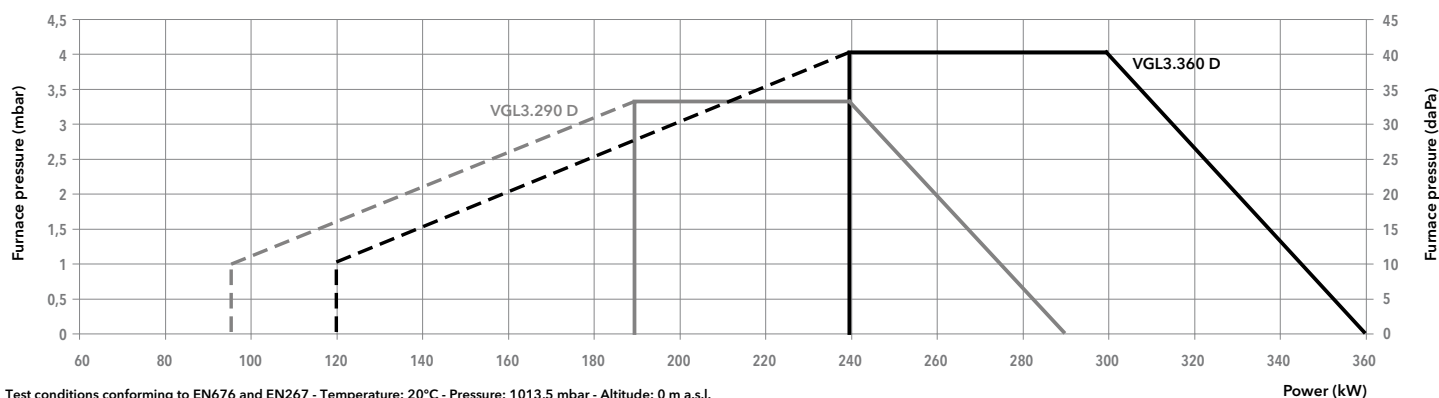

Model	VGL3.290 D		VGL3.360 D	
Operation range	(95) 190 - 290 kW		(120) 240 - 360 kW	
Gas pressure	20 - 300 mbar		20 - 300 mbar	
Control box / flame detection	TCG2... / ionization		TCG2... / ionization	
Fan motor	230 V - 50 Hz - 300 W		230 V - 50 Hz - 300 W	
Electrical consumption	512 W		512 W	
Acoustic level (LpA)	67 dB(A)		69 dB(A)	
CE certificate	0085 CP 0304		0085 CP 0304	
Head lenght	KN	KL	KN	KL
Complete burner code	MB-ZRDLE 420 d1"1/2-Rp2"	-	3834467	3834468
	MB-ZRDLE 412 d1"1/4-Rp1"1/4	3834461	3834465	3834466
	MB-ZRDLE 407 d3/4"-Rp3/4"	3834459	3834460	3834464

### OTHER AVAILABLE VERSIONS

 Versions for continuous ventilation and post-ventilation

### SCOPE OF SUPPLY

The burner is delivered in its package complete with:

- 1 burner head with flange seal and securing screws
- 1 compact gas train with gas filter; the gas filter is built-in for threaded valves (up to 2") and separated for flanged ones (DN65/80/100)
- 1 bag containing installation fittings
- 1 bag containing technical documentation (instruction manual, technical data, electrical diagram, exploded view and spare parts list)

DIMENSIONS (mm)

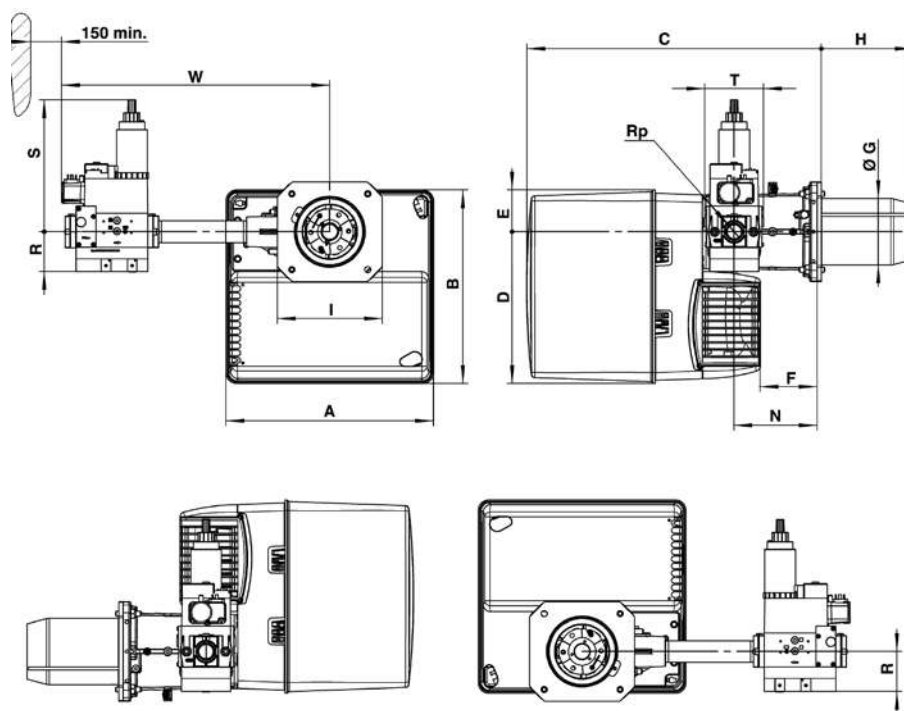

Gas train model	A	B	C	D	E	F	ØG	H		I	N	Rp	R	S	T	W
								KN	KL							
d1"1/2-Rp2"	406	379	576	297	82	120	130	180	320	195x205	170	2"	80	330	100	603
d1"1/4-Rp1"1/4	406	379	576	297	82	120	130	180	320	195x205	170	1"1/4	55	260	145	526
d3/4"-Rp3/4"	406	379	576	297	82	120	130	180	320	195x205	170	3/4"	46	210	120	479

Connecting flange

Øa (mm)	b (mm)	c	d
155-190	175-220	M10	45°

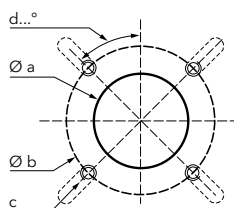

PACKAGING

The burner is delivered on a pallet in 3 packages containing:

- burner housing
- combustion head
- gas train and filter

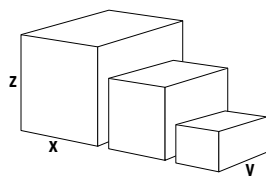

Component		Dimensions (mm)			Gross weight (kg)
		X	Y	Z	
Burner body	VGL3.290 D	440	400	520	21
	VGL3.360 D	440	400	520	22
Combustion head	KN	650	210	260	6
	KL	780	210	260	7
Gas train	d1"1/2-Rp2"	600	400	240	14
	d1"1/4-Rp1"1/4	440	320	240	10
	d3/4"-Rp3/4"	440	320	240	7

## VGL3.290 D, VGL3.360 D

95 ... 360 kW

2 stages in gas (Low NOx class 3) / 2 stages in light oil

### PRESSURE LOSS [BURNER HEAD + GAS TRAIN] (mbar)

#### VGL3.290 D

Burner output (kW)	Natural gas G20 Hi = 10,35 kWh/m <sup>3</sup>		Natural gas G25 Hi = 8,83 kWh/m <sup>3</sup>	
	d3/4"-Rp3/4"	d1"1/4-Rp1"1/4	d3/4"-Rp3/4"	d1"1/4-Rp1"1/4
190	14	6	18	6
210	17	8	22	8
230	20	10	26	10
250	23	11	31	11
270	27	13	37	13
290	32	16	43	16

#### Natural gas G20

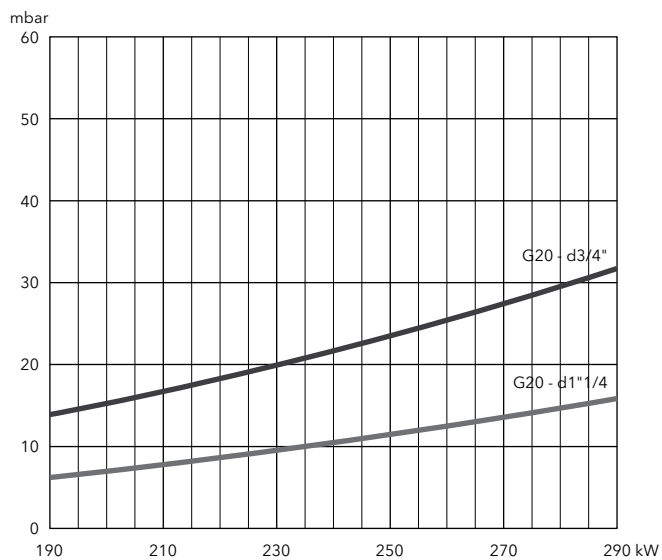

#### Natural gas G25

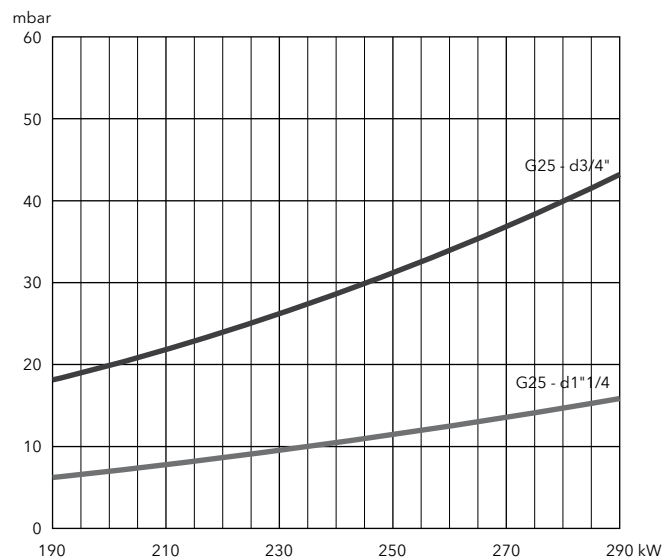



**PRESSURE LOSS [BURNER HEAD + GAS TRAIN] (mbar)**

**VGL3.360 D**

Burner output (kW)	Natural gas G20 Hi = 10,35 kWh/m <sup>3</sup>		Natural gas G25 Hi = 8,83 kWh/m <sup>3</sup>		
	d3/4"-Rp3/4"	d1"1/4-Rp1"1/4	d3/4"-Rp3/4"	d1"1/4-Rp1"1/4	d1"1/2-Rp2"
240	22	9	25	9	8
280	29	12	35	12	11
320	38	16	46	16	14
360	49	21	59	21	18

**Natural gas G20**

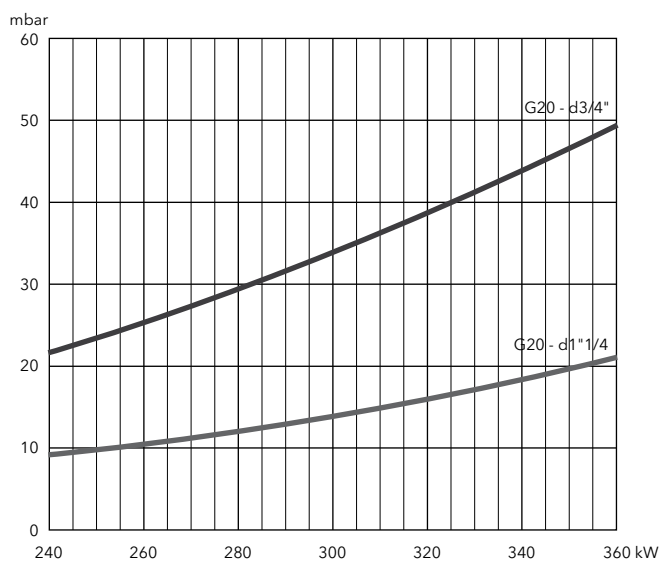

**Natural gas G25**

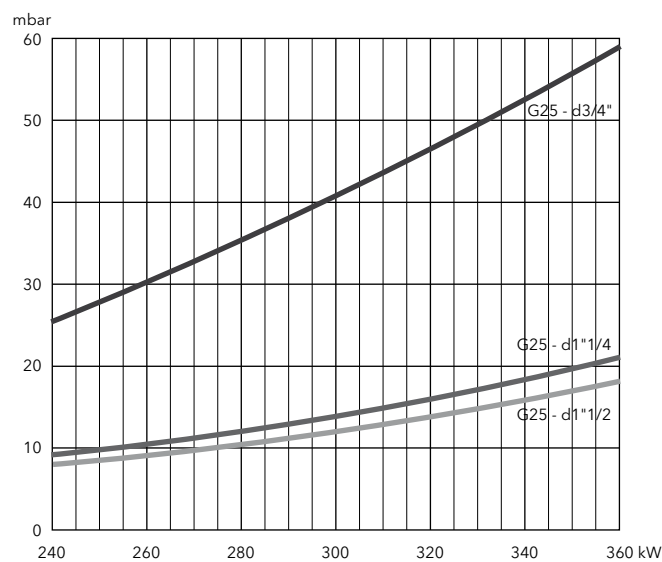

## VGL4.460 DP, VGL4.610 DP

168 ... 610 kW

2 stages progressive/modulating pneumatic in gas (Low NOx class 3) / 2 stages in oil

- **Fuels:** natural gas (G20/G25,  $H_u = 8,83...10,35 \text{ kWh/m}^3$ );  
light oil (viscosity  $6 \text{ mm}^2/\text{s}$  at  $20^\circ\text{C}$ ,  $H_u = 11,86 \text{ kWh/kg}$ )
- **Emissions:** Low NOx class 3 in gas ( $\leq 80 \text{ mg/kWh}$ ) according to EN676  
Low NOx class 2 in light oil ( $\leq 185 \text{ mg/kWh}$ ) according to EN267
- **Operation:** two stage progressive or modulating with the installation of a power regulator and dedicated probes (see pag. 180) in gas and two stages in light oil
- **Protection level:** IP 41



### TECHNICAL DATA

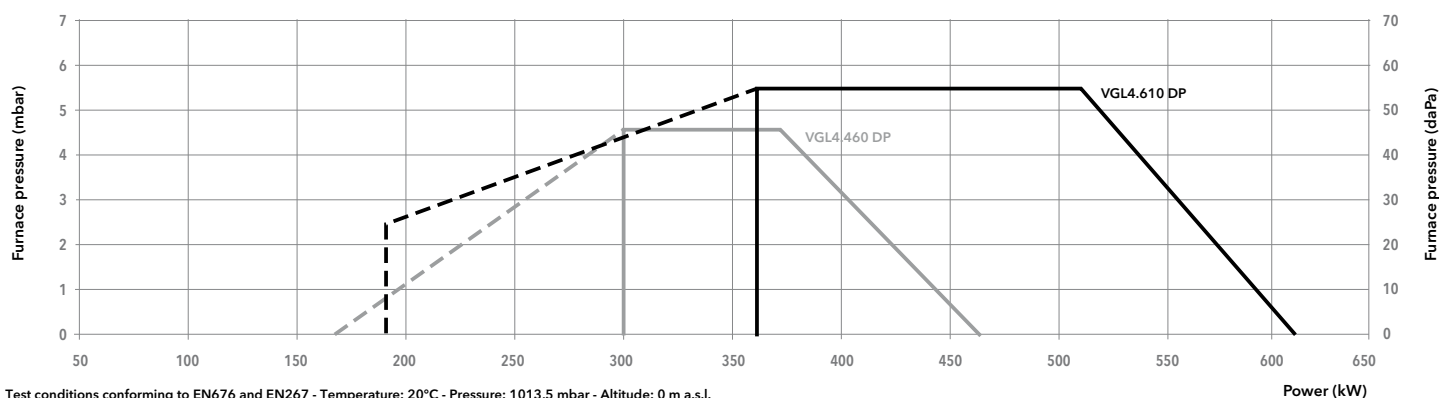

Model	VGL4.460 DP		VGL4.610 DP	
Operation range	(168) 300 - 460 kW		(190) 360 - 610 kW	
Gas pressure	20 - 300 mbar		20 - 300 mbar	
Control box / flame detection	TCG5... / ionization		TCG5... / ionization	
Fan motor	230 V - 50 Hz - 420 W		230 V - 50 Hz - 750 W	
Electrical consumption	68 + 522 W		68 + 720 W	
Acoustic level (LpA)	70 dB(A)		71 dB(A)	
CE certificate	0085 CP 0304		0085 CP 0304	
Head lenght	KN	KL	KN	KL
Complete burner code	MB-VEF 420 d1"1/2-Rp2"	<b>3834576</b>	<b>3834577</b>	<b>3834582</b>
	MB-VEF 412 d1"1/4-Rp1"1/4"	<b>3834574</b>	<b>3834575</b>	<b>3834580</b>
	MB-VEF 407 d3/4"-Rp1"	<b>3834572</b>	<b>3834573</b>	<b>3834578</b>
				<b>3834583</b>
				<b>3834581</b>
				<b>3834579</b>

### OTHER AVAILABLE VERSIONS

Versions for continuous ventilation and post-ventilation

### SCOPE OF SUPPLY

The burner is delivered in its package complete with:

- 1 burner head with flange seal and securing screws
- 1 compact gas train with gas filter; the gas filter is built-in for threaded valves (up to 2") and separated for flanged ones (DN65/80/100)
- 1 bag containing installation fittings
- 1 bag containing technical documentation (instruction manual, technical data, electrical diagram, exploded view and spare parts list)



DIMENSIONS (mm)

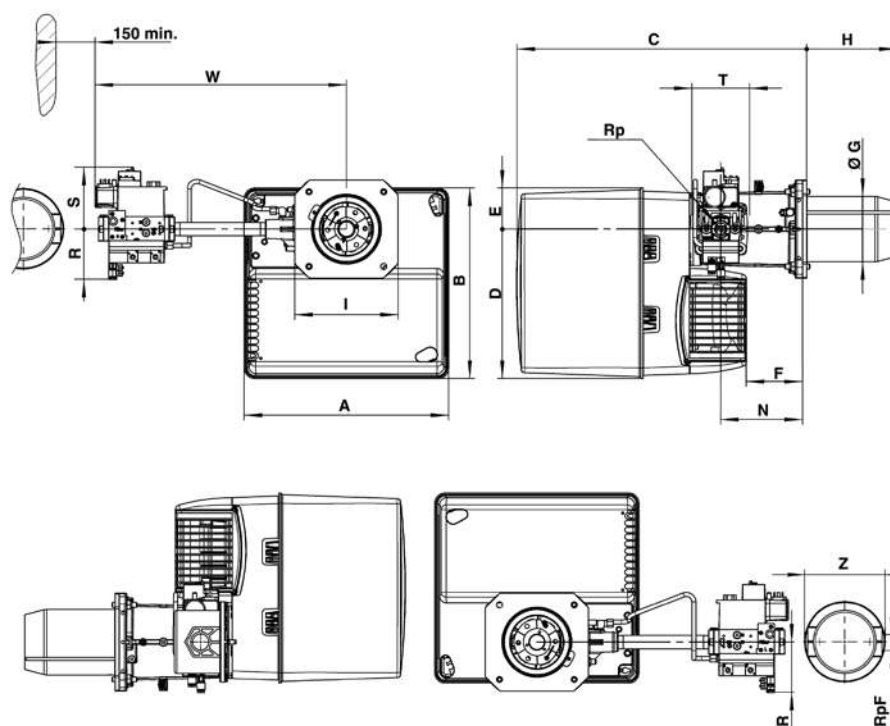

Gas train model	A	B	C	D	E	F	Ø G	H		I	N	Rp	R	S	T	W	RpF	Z
								KN	KL									
d1"1/2-Rp2"	465	475	640	377	97	149	150	220	360	245	195	2"	100	185	100	613	-	-
d1"1/4-Rp1"1/4	465	475	640	377	97	149	150	220	360	245	195	1"1/4	80	175	145	536	-	-
d3/4"-Rp1"	465	475	640	377	97	149	150	220	360	245	195	1"	70	160	120	489	1"	160

Connecting flange

Øa (mm)	b (mm)	c	d
180-240	200-270	M10	45°

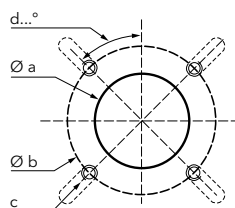

PACKAGING

The burner is delivered on a pallet in 3 packages containing:

- burner housing
- combustion head
- gas train and filter

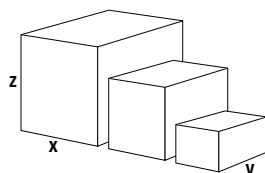

Component		Dimensions (mm)			Gross weight (kg)
		X	Y	Z	
Burner body	VGL4.460 DP	490	490	590	28,6
	VGL4.610 DP	490	490	590	32,7
Combustion head	KN	750	260	295	8,9
	KL	895	260	295	10,1
Gas train	d1"1/2-Rp2"	670	550	380	12
	d1"1/4-Rp1"1/4	600	400	240	11
	d3/4"-Rp1"	600	400	240	7

## VGL4.460 DP, VGL4.610 DP

168 ... 610 kW

2 stages progressive/modulating pneumatic in gas (Low NOx class 3) / 2 stages in oil

### PRESSURE LOSS [BURNER HEAD + GAS TRAIN] (mbar)

#### VGL4.460 DP

Burner output (kW)	Natural gas G20 Hi = 10,35 kWh/m <sup>3</sup>		Natural gas G25 Hi = 8,83 kWh/m <sup>3</sup>		
	d3/4"-Rp3/4"	d1"1/4-Rp1"1/4	d3/4"-Rp3/4"	d1"1/4-Rp1"1/4	d1"1/2-Rp2"
300	37	7	50	13	8
340	47	10	65	17	10
380	59	12	81	21	13
420	72	15	99	26	15
460	86	18	118	31	19

#### Natural gas G20

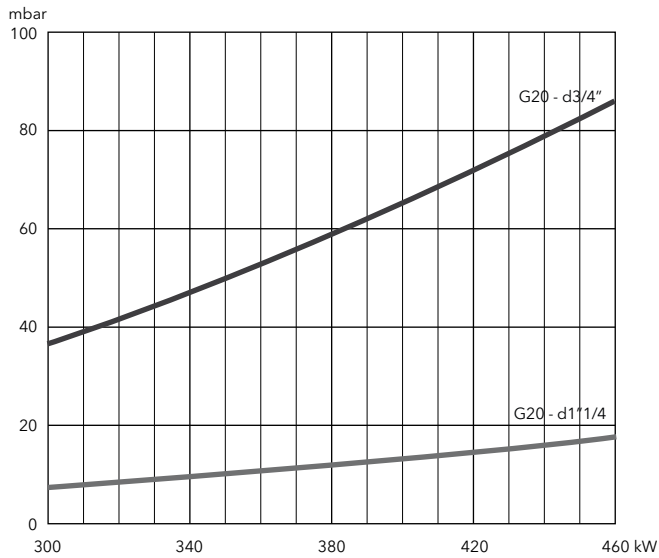

#### Natural gas G25

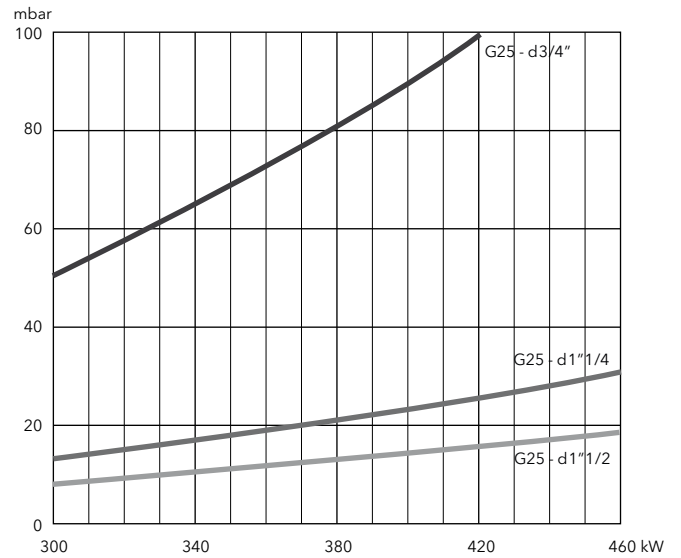





**PRESSURE LOSS [BURNER HEAD + GAS TRAIN] (mbar)**

**VGL4.610 DP**

Burner output (kW)	Natural gas G20 Hi = 10,35 kWh/m <sup>3</sup>			Natural gas G25 Hi = 8,83 kWh/m <sup>3</sup>	
	d3/4"-Rp3/4"	d1"1/4-Rp1"1/4	d1"1/2-Rp2"	d1"1/4-Rp1"1/4	d1"1/2-Rp2"
300	51	9	5	12	8
400	91	16	9	21	14
500	142	24	15	33	22
600	204	35	21	48	32

**Natural gas G20**

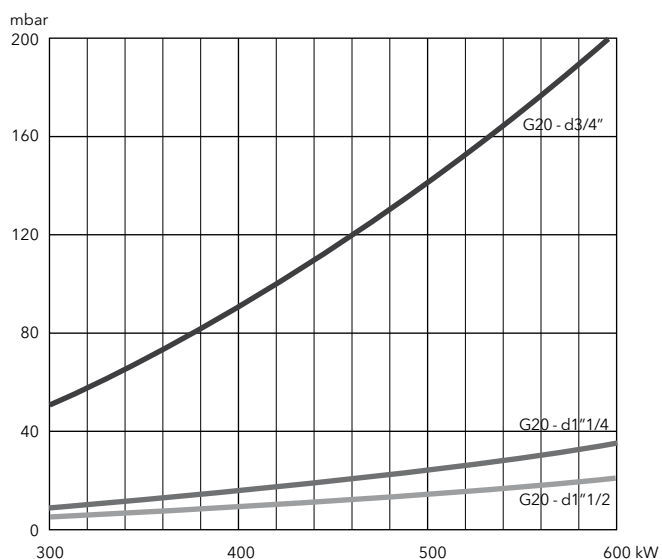

**Natural gas G25**

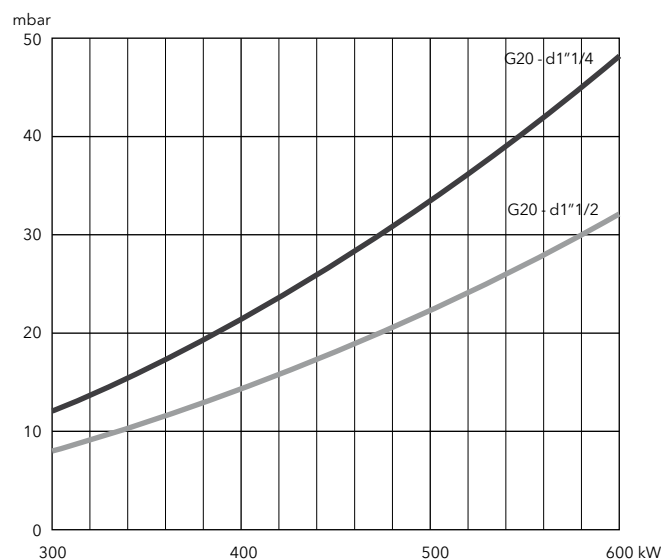

## VGL5.700 M, VGL5.1000 M

200 ... 1000 kW

2 stages progressive/modulating electronic in gas (Low NOx Class 3) / 3 stages in oil

- **Fuels:** natural gas (G20/G25,  $H_u = 8,83...10,35 \text{ kWh/m}^3$ );  
light oil (viscosity  $6 \text{ mm}^2/\text{s}$  at  $20^\circ\text{C}$ ,  $H_u = 11,86 \text{ kWh/kg}$ )
- **Emissions:** Low NOx class 3 in gas ( $\leq 80 \text{ mg/kWh}$ ) according to EN676  
Low NOx class 2 in light oil ( $\leq 185 \text{ mg/kWh}$ ) according to EN267
- **Operation:** two stage progressive or modulating with the installation of a power regulator and dedicated probes (see pag. 180) in gas and three stages in light oil
- **Protection level:** IP 41



### TECHNICAL DATA

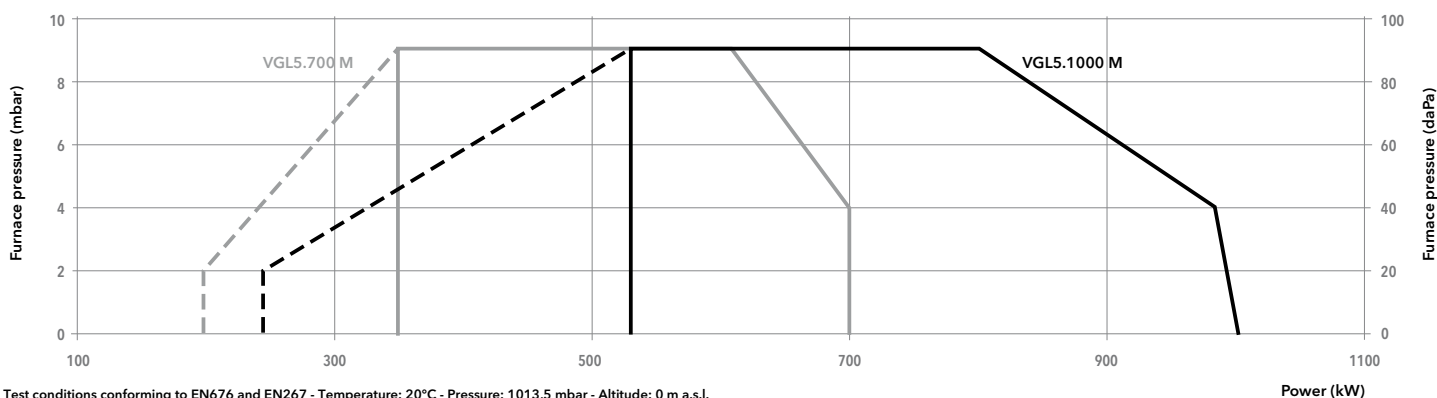

Model	VGL5.700 M /TC			VGL5.1000 M /TC		
Operation range	(200) 350 - 700 kW			(240) 530 - 1000 kW		
Gas pressure	20 - 300 mbar			20 - 300 mbar		
Control box / flame detection	BT3... / QRA 2			BT3... / QRA 2		
Fan motor	230/400 V - 50 Hz - 1,1 kW			230/400 V - 50 Hz - 1,5 kW		
Nozzle	4,5 US gal/h $45^\circ\text{B}$ / 5 US gal/h $45^\circ\text{B}$			5 US gal/h $45^\circ\text{B}$ / 8,5 US gal/h $45^\circ\text{B}$		
Electrical consumption	2000 W			2200 W		
Acoustic level (LpA)	78 dB(A)			81 dB(A)		
CE certificate	1312 AQ 924			1312 AQ 925		
Head lenght	KN	KL	KM	KN	KL	KM
Complete burner code	VG D 40-065 s65-DN65	-	-	3836654	3836656	3836655
	MBC1900 d65-DN65	-	-	3836657	3836659	3836658
	MBC1200 d2"-Rp2"	3836645	3836647	3836646	3836660	3836662
	MBC700 d1"1/2-Rp2"	3836648	3836650	3836649	3836663	3836665
	MBC300 d3/4"-Rp1"1/4	3836651	3836653	3836652	3836666	3836668

### OTHER AVAILABLE VERSIONS

 Versions for continuous ventilation and post-ventilation

### SCOPE OF SUPPLY

The burner is delivered in its package complete with:

- 1 burner head with flange seal and securing screws
- 1 compact gas train with gas filter; the gas filter is built-in for threaded valves (up to 2") and separated for flanged ones (DN65/80/100)
- 1 bag containing installation fittings
- 1 bag containing technical documentation (instruction manual, technical data, electrical diagram, exploded view and spare parts list)



DIMENSIONS (mm)

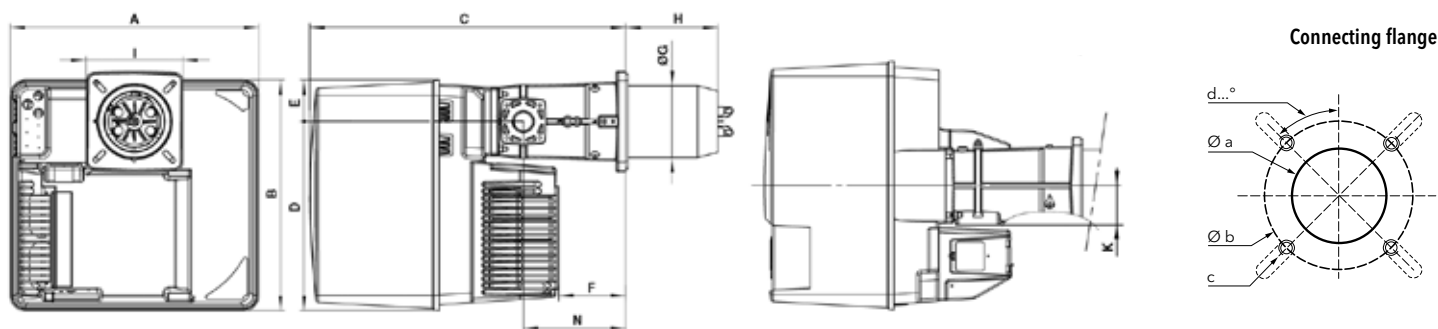

A	B	C	D	E	F	ØG	H			I	K	N
							KN	KM	KL			
581	549	752	450	99	164	170	215	325	435	230x238	89	244

Øa (mm)	b (mm)	c	d
195	220-260	M10	45°

Gas trains

Gas train "d":

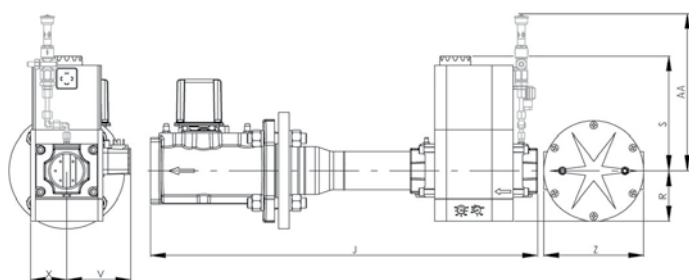

Model	J	R	S	V	X	Z	AA*
d65-DN65	490	183	245	110	98	290	385
d2"-Rp2"	700	96	330	125	81	-	385
d1"1/2-Rp2"	622	80	185	102	57	-	320
d3/4"-Rp1"1/4	460	60	173	88	58	-	320

Gas train "s":

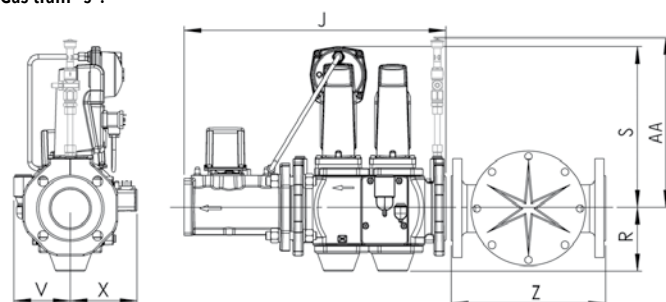

Model	J	R	S	V	X	Z	AA*
s65-DN65	490	118	300	106	126	290	365

\*: for PED configuration

PACKAGING

The burner is delivered on a pallet in 3 packages containing:

- burner housing
- combustion head
- gas train and filter

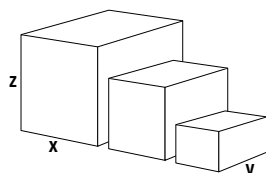

Component		Dimensions (mm)			Gross weight (kg)
		X	Y	Z	
Burner body	VG5.700 M	800	600	850	70
	VG5.1000 M	800	600	850	70
Combustion head	KN	780	265	280	13
	KL	1010	265	280	16
	KM	1010	265	280	15
Gas train	s65-DN65/TC	670	530	380	26
	d65-DN65/TC	670	530	380	17
	d2"-Rp2"/TC	670	530	380	12
	d1"1/2-Rp2"/TC	670	530	380	12
	d3/4"-Rp1"1/4/TC	600	400	240	7

## VGL5.700 M, VGL5.1000 M

200 ... 1000 kW

2 stages progressive/modulating electronic in gas (Low NOx Class 3) / 3 stages in oil

### PRESSURE LOSS [BURNER HEAD + GAS TRAIN] (mbar)

#### VGL5.700 M

Burner output (kW)	Natural gas G20 Hi = 10,35 kWh/m <sup>3</sup>					Natural gas G25 Hi = 8,83 kWh/m <sup>3</sup>					LPG G31
	d3/4-Rp1"1/4	d1"1/2-Rp2"	d2"-Rp2"	d65-DN65	s65-DN65	d3/4-Rp1"1/4	d1"1/2-Rp2"	d2"-Rp2"	d65-DN65	s65-DN65	d1"1/2-Rp2"
500	31	9	8	5	5	37	11	9	5	6	6
600	43	13	10	8	8	53	16	12	7	9	8
700	58	17	13	10	10	73	21	15	10	12	10
800	76	22	16	13	13	96	28	19	13	16	13
900	97	27	19	17	17	124	35	23	17	20	16

#### Natural gas G20

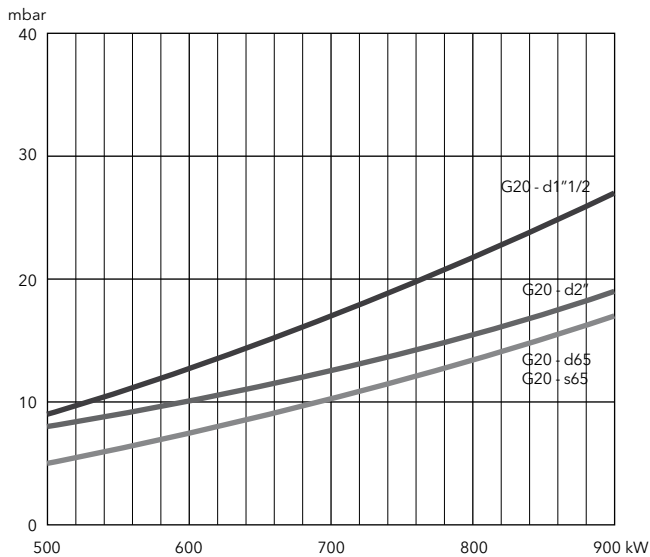

#### Natural gas G25

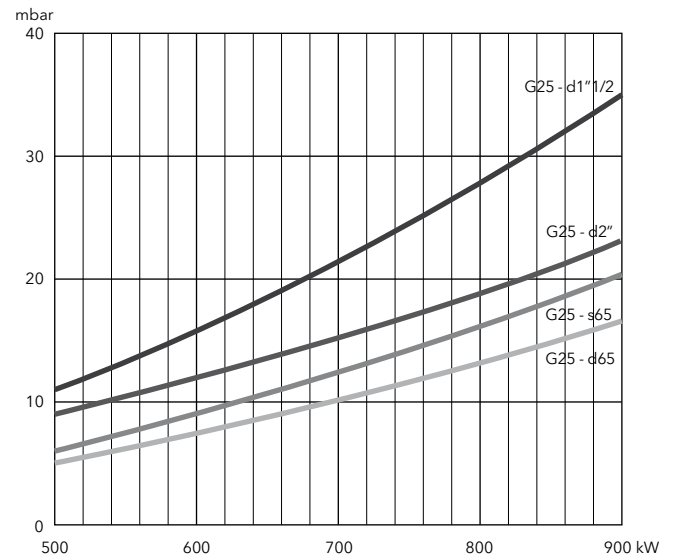

#### Natural gas G20, G25

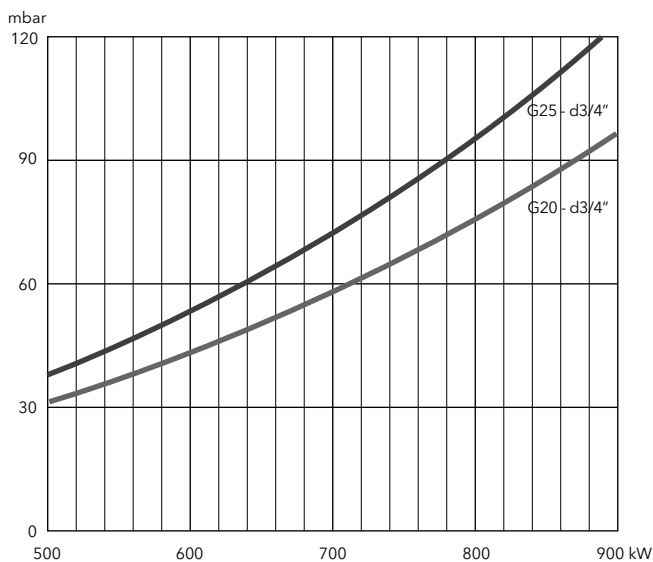

#### LPG

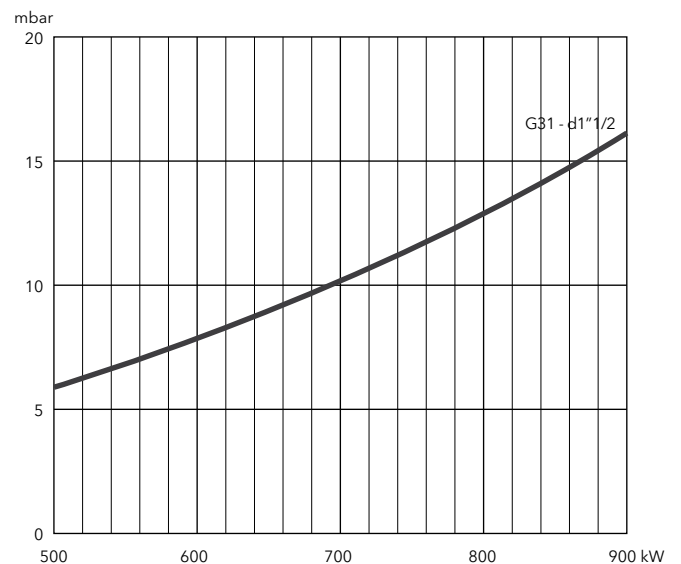



**PRESSURE LOSS [BURNER HEAD + GAS TRAIN] (mbar)**

**VGL5.1000 M**

Burner output (kW)	Natural gas G20 Hi = 10,35 kWh/m <sup>3</sup>					Natural gas G25 Hi = 8,83 kWh/m <sup>3</sup>					LPG G31
	d3/4-Rp1"1/4	d1"1/2-Rp2"	d2"-Rp2"	d65-DN65	s65-DN65	d3/4-Rp1"1/4	d1"1/2-Rp2"	d2"-Rp2"	d65-DN65	s65-DN65	d1"1/2-Rp2"
700	40	16	12	10	10	60	21	14	10	12	10
800	53	20	14	13	13	79	27	17	13	15	12
900	68	25	17	16	16	100	34	21	16	19	15
1000	84	31	21	20	20	126	42	26	20	24	18
1100	103	37	25	24	24	154	50	31	24	29	22
1200	123	44	29	29	29	186	59	36	29	34	26

**Natural gas G20**

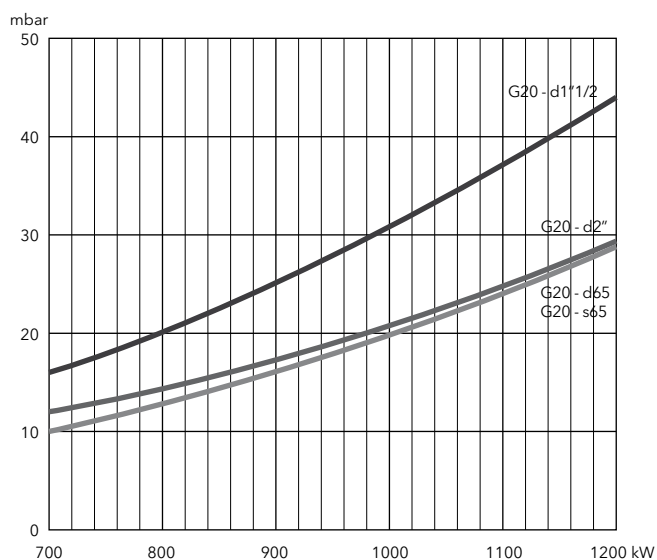

**Natural gas G25**

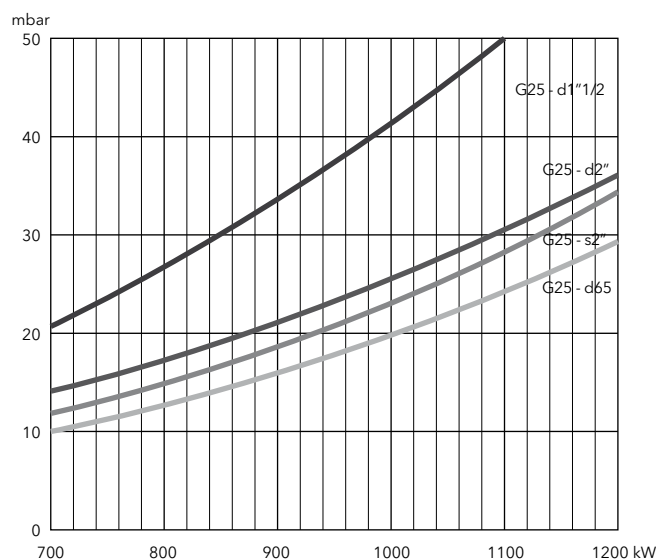

**Natural gas G20, G25**

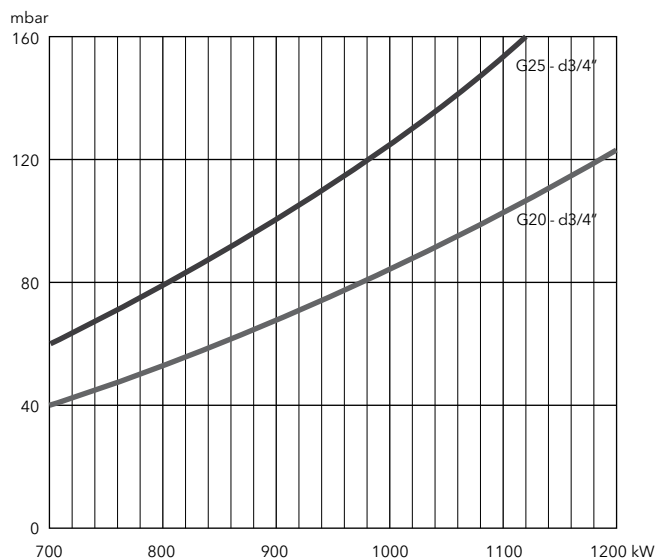

**LPG**

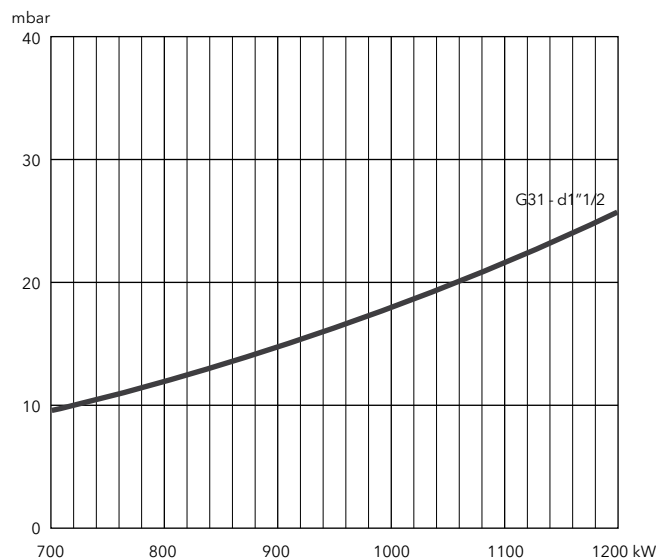

## VGL6.1600 M, VGL6.2100 M

300 ... 2050 kW

2 stage progressive/modulating electronic (Low NOx class 3) / 3 stages in oil

- **Fuels:** natural gas (G20/G25,  $H_u = 8,83...10,35 \text{ kWh/m}^3$ );  
light oil (viscosity  $6 \text{ mm}^2/\text{s}$  at  $20^\circ\text{C}$ ,  $H_u = 11,86 \text{ kWh/kg}$ )
- **Emissions:** Low NOx class 3 in gas ( $\leq 80 \text{ mg/kWh}$ ) according to EN676  
Low NOx class 2 in light oil ( $\leq 185 \text{ mg/kWh}$ ) according to EN267
- **Operation:** two stage progressive or modulating with the installation of a power regulator and dedicated probes (see pag. 180) in gas and three stages in light oil
- **Protection level:** IP 41



### TECHNICAL DATA

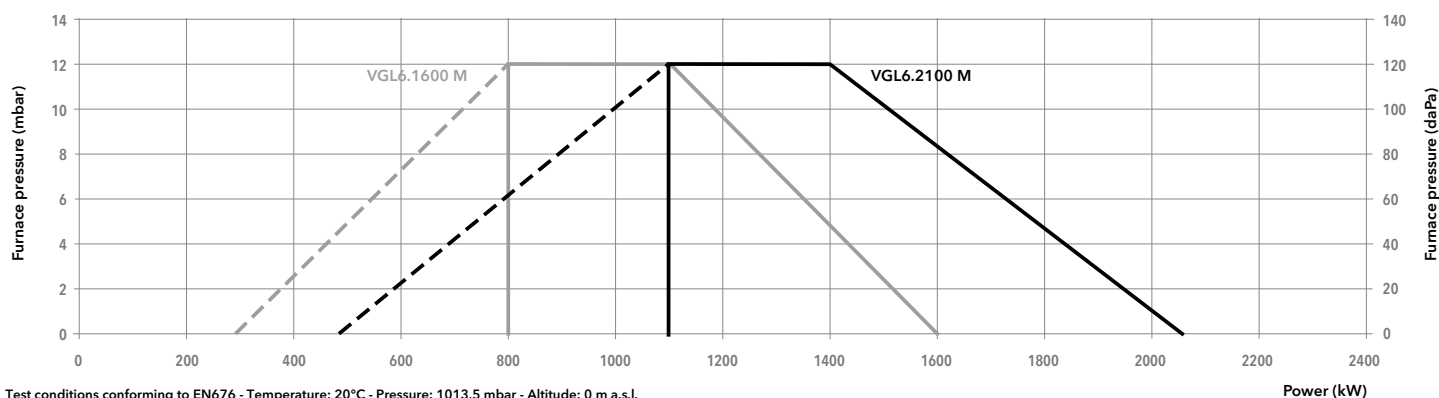

Model	VGL6.1600 M /TC			VGL6.2100 M /TC				
Operation range	(300) 800 - 1600 kW			(480) 1100 - 2050 kW				
Gas pressure	20 - 300 mbar			20 - 300 mbar				
Control box / flame detection	BT3... / QRA 2			BT3... / QRA 2				
Fan motor	230/400 V - 50 Hz - 2,2 kW			230/400 V - 50 Hz - 2,7 kW				
Electrical consumption	2800 W			3400 W				
Acoustic level (LpA)	77,2 dB(A)			79 dB(A)				
CE certificate	1312 BM 3427			1312 BM 3428				
Head lenght		KN	KL	KM	KN	KL	KM	
Complete	VGD 40-065	s65-DN65/TC	<b>3836669</b>	<b>3836671</b>	<b>3836670</b>	<b>3836681</b>	<b>3836683</b>	<b>3836682</b>
burner code	MBC1900	d65-DN65/TC	<b>3836672</b>	<b>3836674</b>	<b>3836673</b>	<b>3836684</b>	<b>3836686</b>	<b>3836685</b>
	MBC1200	d2"-Rp2"/TC	<b>3836675</b>	<b>3836677</b>	<b>3836676</b>	<b>3836687</b>	<b>3836689</b>	<b>3836688</b>
	MBC700	d1"1/2-Rp2"/TC	<b>3836678</b>	<b>3836680</b>	<b>3836679</b>	<b>3836690</b>	<b>3836692</b>	<b>3836691</b>

### OTHER AVAILABLE VERSIONS

 Versions for continuous ventilation and post-ventilation

### SCOPE OF SUPPLY

The burner is delivered in its package complete with:

- 1 burner head with flange seal and securing screws
- 1 compact gas train with gas filter; the gas filter is built-in for threaded valves (up to 2") and separated for flanged ones (DN65/80/100)
- 1 bag containing installation fittings
- 1 bag containing technical documentation (instruction manual, technical data, electrical diagram, exploded view and spare parts list)



DIMENSIONS (mm)

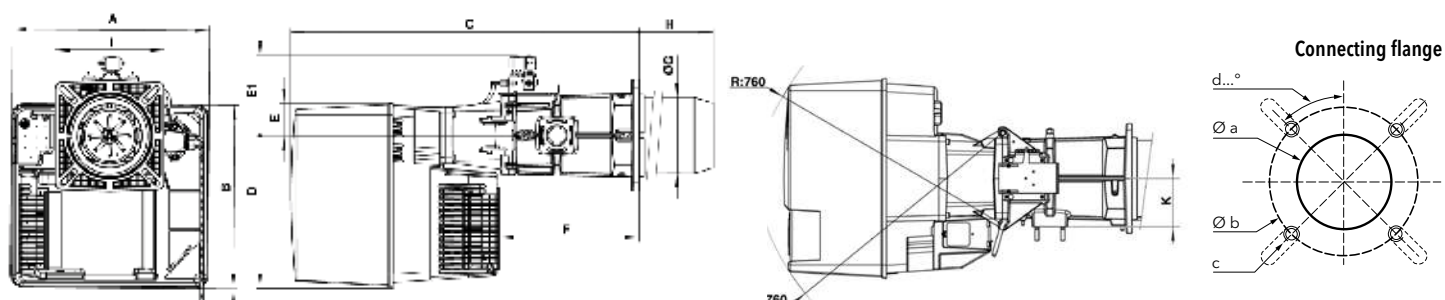

A	B	C	D	E	E1	F	ØG	H			I	K	N
								KN	KM	KL			
592	553	1050	456	97	239	421	227	270	370	470	326x335	144	247

Øa (mm)	b (mm)	c	d
250	300-400	M12	45°

Gas trains

Gas train "d":

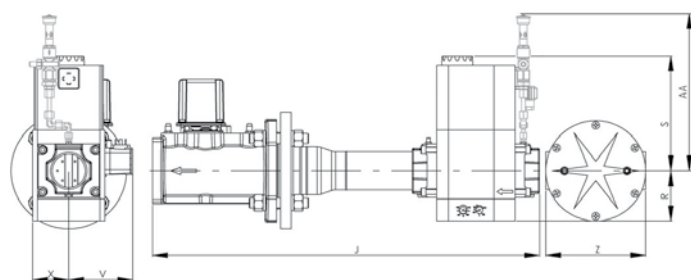

Model	J	R	S	V	X	Z	AA*
d65-DN65	490	183	245	110	98	290	385
d2"-Rp2"	700	96	330	125	81	-	385
d1"1/2-Rp2"	622	80	185	102	57	-	320

Gas train "s":

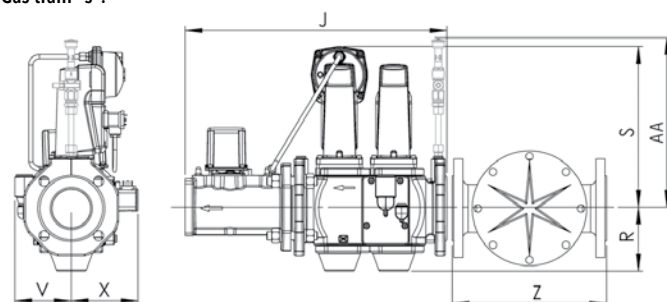

Model	J	R	S	V	X	Z	AA*
s65-DN65	490	118	300	106	126	290	365

\*: for PED configuration

PACKAGING

The burner is delivered on a pallet in 3 packages containing:

- burner housing
- combustion head
- gas train and filter

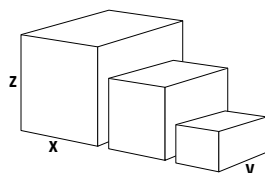

Component		Dimensions (mm)			Gross weight (kg)
		X	Y	Z	
Burner body	VGL6.1600 M	1200	800	1440	140
	VGL6.2100 M	1200	800	1440	140
Combustion head	KN	800	380	240	28
	KL	1000	380	420	30
	KM	1000	380	420	31
Gas train	s65-DN65/TC	790	600	500	29,4
	d65-DN65/TC	670	550	380	33
	d2"-Rp2"/TC	670	550	380	22
	d1"1/2-Rp2"/TC	670	550	380	21

## VGL6.1600 M, VGL6.2100 M

300 ... 2050 kW

2 stage progressive/modulating electronic (Low NOx Class 3) / 3 stages in oil

### PRESSURE LOSS [BURNER HEAD + GAS TRAIN] (mbar)

#### VGL6.1600 M

Burner output (kW)	Natural gas G20 Hi = 10,35 kWh/m <sup>3</sup>				Natural gas G25 Hi = 8,83 kWh/m <sup>3</sup>				LPG G31 Hi = 25,89 kWh/m <sup>3</sup>
	d1"1/2-Rp2"	d2"-Rp2"	d65-DN65	s65-DN65	d1"1/2-Rp2"	d2"-Rp2"	d65-DN65	s65-DN65	d1"1/2-Rp2"
800	16	9	6	6	22	12	8	8	8
1000	25	13	10	9	34	18	12	12	12
1200	35	18	14	13	48	24	18	18	17
1400	47	24	19	18	64	32	24	24	22
1600	61	31	25	23	83	42	31	31	29

#### Natural gas G20

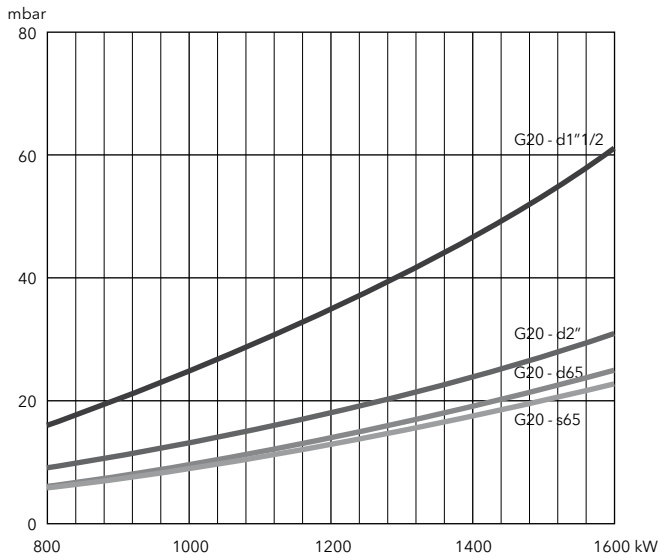

#### Natural gas G25

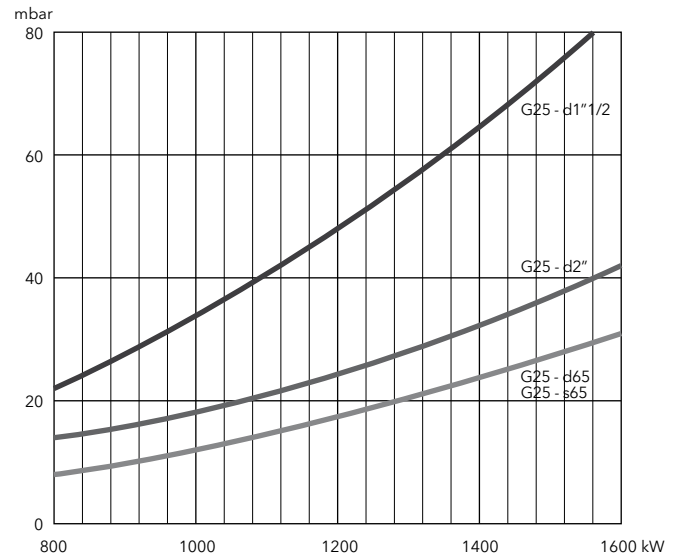

#### LPG

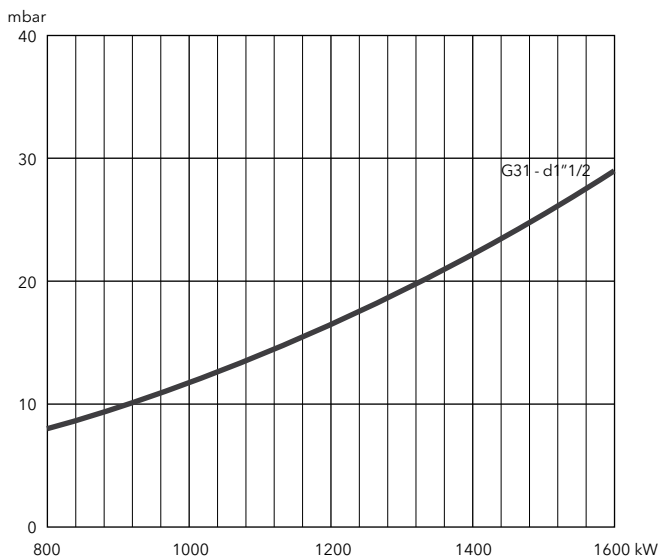





**PRESSURE LOSS [BURNER HEAD + GAS TRAIN] (mbar)**

**VGL6.2100 M**

Burner output (kW)	Natural gas G20 Hi = 10,35 kWh/m <sup>3</sup>				Natural gas G25 Hi = 8,83 kWh/m <sup>3</sup>				LPG G31 Hi = 25,89 kWh/m <sup>3</sup>	
	d1"1/2-Rp2"	d2"-Rp2"	d65-DN65	s65-DN65	d1"1/2-Rp2"	d2"-Rp2"	d65-DN65	s65-DN65	d1"1/2-Rp2"	d2"-Rp2"
1100	28	15	12	11	39	21	15	15	13	9
1300	39	21	16	16	54	29	21	22	18	11
1500	51	27	21	21	71	37	28	29	23	14
1700	64	34	27	27	91	47	36	37	29	17
1900	80	41	34	34	114	59	45	46	36	20

**Natural gas G20**

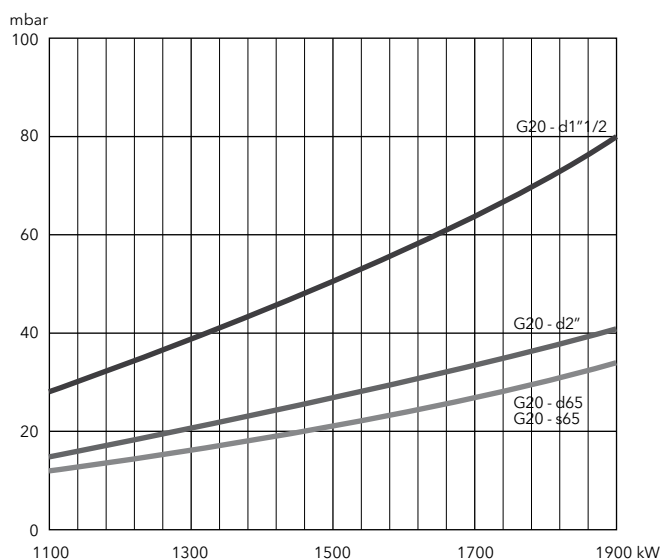

**Natural gas G25**

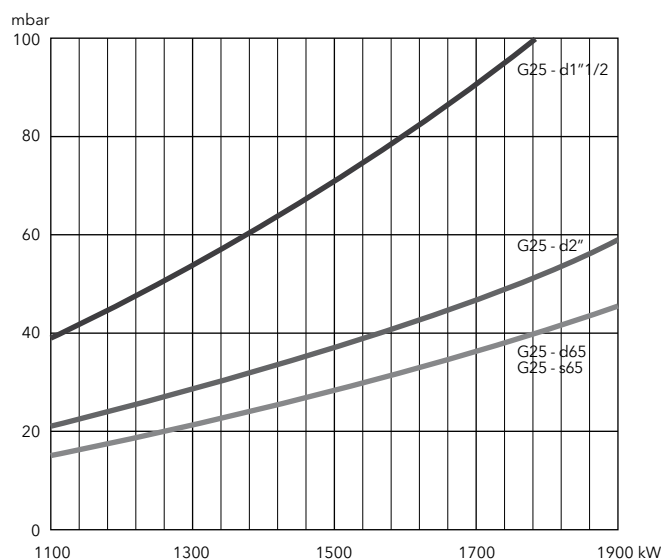

**LPG**

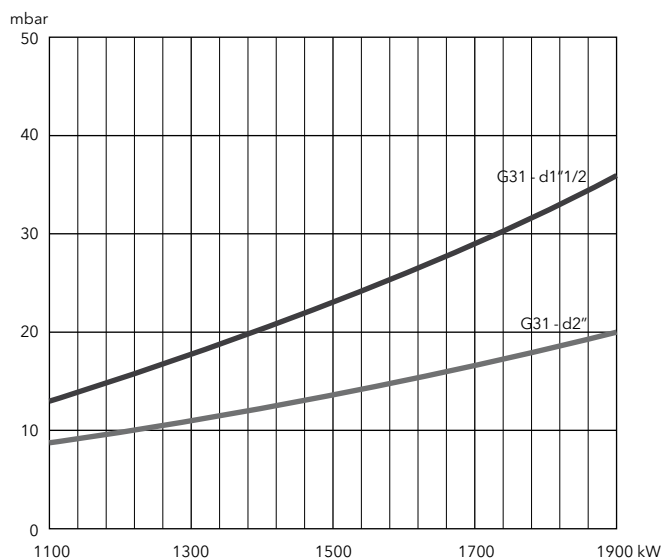

## VGL5.700 M V, VGL5.1000 M V

200 ... 1000 kW

2 stages progressive/modulating electronic in gas (Low NOx Class 3) / 3 stages in oil + fan speed control

- **Fuels:** natural gas (G20/G25,  $H_u = 8,83...10,35 \text{ kWh/m}^3$ );  
light oil (viscosity  $6 \text{ mm}^2/\text{s}$  at  $20^\circ\text{C}$ ,  $H_u = 11,86 \text{ kWh/kg}$ )
- **Emissions:** Low NOx class 3 in gas ( $\leq 80 \text{ mg/kWh}$ ) according to EN676  
Low NOx class 2 in light oil ( $\leq 185 \text{ mg/kWh}$ ) according to EN267
- **Operation:** two stage progressive or modulating with the installation of a power regulator and dedicated probes (see pag. 180) in gas and three stages in light oil
- **Protection level:** IP 41



### TECHNICAL DATA

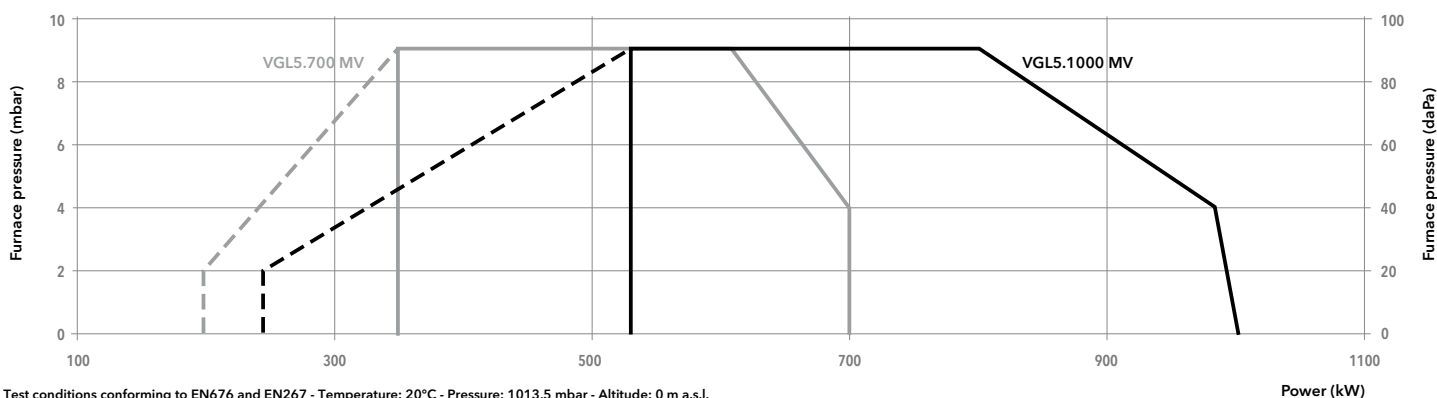

Model	VGL5.700 M V /TC			VGL5.1000 M V /TC				
Operation range	(200) 350 - 700 kW			(240) 530 - 1000 kW				
Gas pressure	20 - 300 mbar			20 - 300 mbar				
Control box / flame detection	BT3... / QRA 2			BT3... / QRA 2				
Fan motor	230/400 V - 50 Hz - 1,1 kW			230/400 V - 50 Hz - 1,5 kW				
Nozzle	4,5 US gal/h $45^\circ\text{B}$ / 5 US gal/h $45^\circ\text{B}$			5 US gal/h $45^\circ\text{B}$ / 8,5 US gal/h $45^\circ\text{B}$				
Electrical consumption	2000 W			2200 W				
Acoustic level (LpA)	78 dB(A)			81 dB(A)				
CE certificate	1312 AQ 924			1312 AQ 925				
Head lenght		KN	KL	KM	KN	KL	KM	
Complete burner code	VDG 40-065	s65-DN65	-	-	-	<b>3836702</b>	<b>3836704</b>	<b>3836703</b>
	MBC1900	d65-DN65	-	-	-	<b>3836705</b>	<b>3836707</b>	<b>3836706</b>
	MBC1200	d2"-Rp2"	<b>3836693</b>	<b>3836695</b>	<b>3836694</b>	<b>3836708</b>	<b>3836710</b>	<b>3836709</b>
	MBC700	d1 1/2"-Rp2"	<b>3836696</b>	<b>3836698</b>	<b>3836697</b>	<b>3836711</b>	<b>3836713</b>	<b>3836712</b>
	MBC300	d3/4"-Rp1 1/4"	<b>3836699</b>	<b>3836701</b>	<b>3836700</b>	<b>3836714</b>	<b>3836716</b>	<b>3836715</b>

### OTHER AVAILABLE VERSIONS

 Versions for continuous ventilation and post-ventilation

### SCOPE OF SUPPLY

The burner is delivered in its package complete with:

- 1 burner head with flange seal and securing screws
- 1 compact gas train with gas filter; the gas filter is built-in for threaded valves (up to 2") and separated for flanged ones (DN65/80/100)
- 1 bag containing installation fittings
- 1 bag containing technical documentation (instruction manual, technical data, electrical diagram, exploded view and spare parts list)



DIMENSIONS (mm)

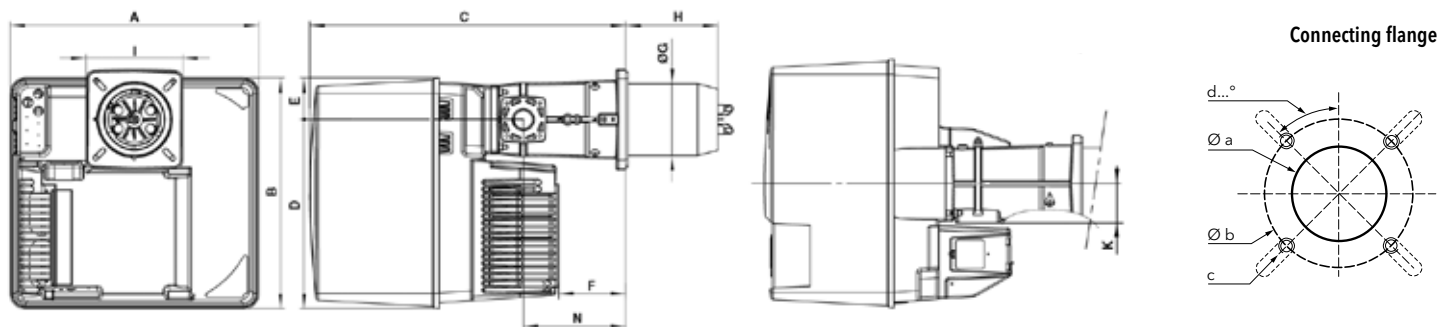

A	B	C	D	E	F	ØG	H			I	K	N
							KN	KM	KL			
581	549	752	450	99	164	170	215	325	435	230x238	89	244

Øa (mm)	b (mm)	c	d
195	220-260	M10	45°

Gas trains

Gas train "d":

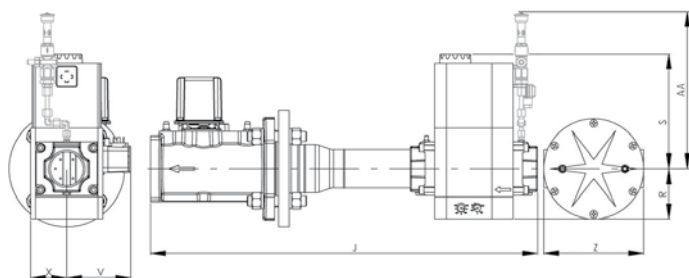

Model	J	R	S	V	X	Z	AA*
d65-DN65	490	183	245	110	98	290	385
d2"-Rp2"	700	96	330	125	81	-	385
d1"1/2-Rp2"	622	80	185	102	57	-	320
d3/4"-Rp1"1/4	460	60	173	88	58	-	320

Gas train "s":

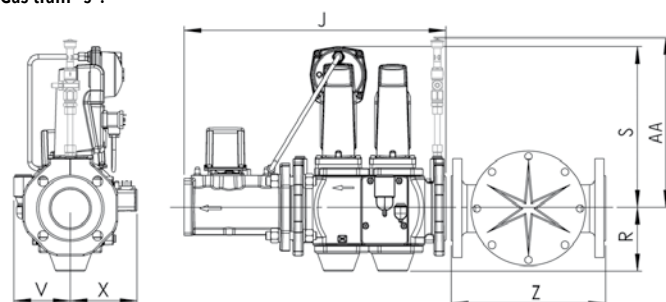

Model	J	R	S	V	X	Z	AA*
s65-DN65	490	118	300	106	126	290	365

\*: for PED configuration

PACKAGING

The burner is delivered on a pallet in 3 packages containing:

- burner housing
- combustion head
- gas train and filter

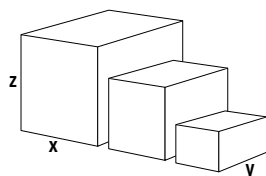

Component		Dimensions (mm)			Gross weight (kg)
		X	Y	Z	
Burner body	VGL5.700 M V	800	600	850	70
	VGL5.1000 M V	800	600	850	70
Combustion head	KN	780	265	280	13
	KL	1010	265	280	16
	KM	1010	265	280	15
Gas train	s65-DN65/TC	670	530	380	26
	d65-DN65/TC	670	530	380	17
	d2"-Rp2"/TC	670	530	380	12
	d1"1/2-Rp2"/TC	670	530	380	12
	d3/4"-Rp1"1/4/TC	600	400	240	7

## VGL5.700 M V, VGL5.1000 M V

200 ... 1000 kW

2 stages progressive/modulating electronic in gas (Low NOx Class 3) / 3 stages in oil + fan speed control

### PRESSURE LOSS [BURNER HEAD + GAS TRAIN] (mbar)

#### VGL5.700 M V

Burner output (kW)	Natural gas G20 Hi = 10,35 kWh/m <sup>3</sup>					Natural gas G25 Hi = 8,83 kWh/m <sup>3</sup>					LPG G31
	d3/4-Rp1"1/4	d1"1/2-Rp2"	d2"-Rp2"	d65-DN65	s65-DN65	d3/4-Rp1"1/4	d1"1/2-Rp2"	d2"-Rp2"	d65-DN65	s65-DN65	d1"1/2-Rp2"
500	31	9	8	5	5	37	11	9	5	6	6
600	43	13	10	8	8	53	16	12	7	9	8
700	58	17	13	10	10	73	21	15	10	12	10
800	76	22	16	13	13	96	28	19	13	16	13
900	97	27	19	17	17	124	35	23	17	20	16

#### Natural gas G20

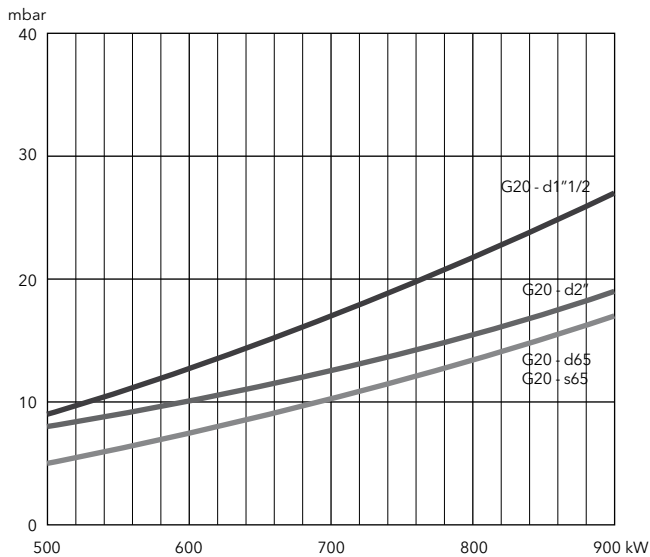

#### Natural gas G25

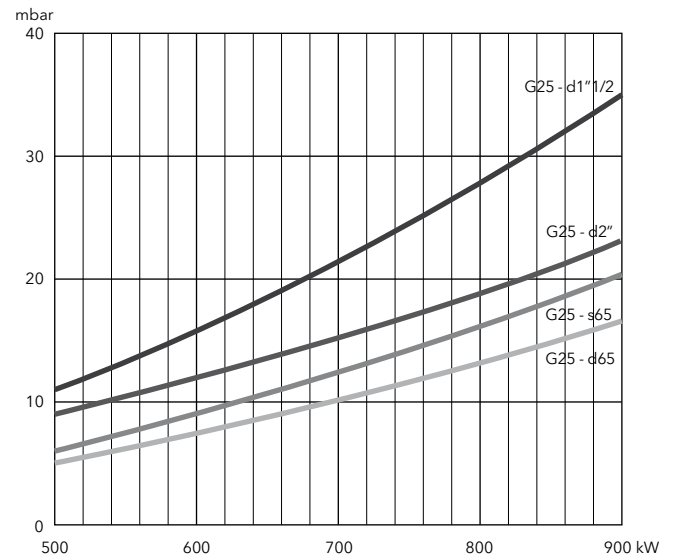

#### Natural gas G20, G25

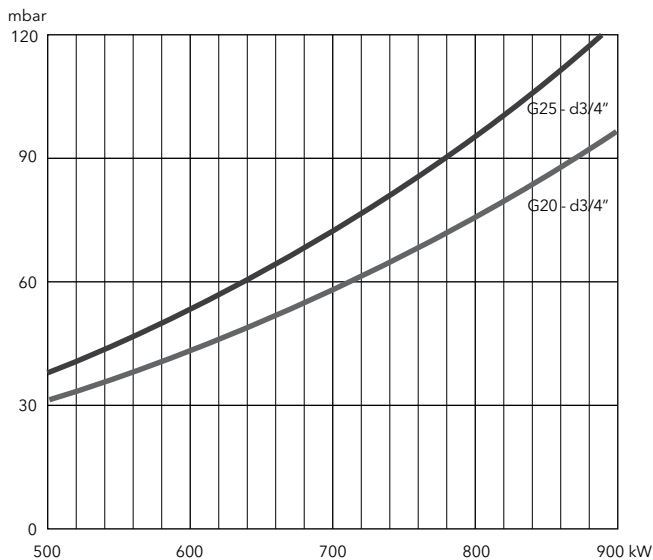

#### LPG

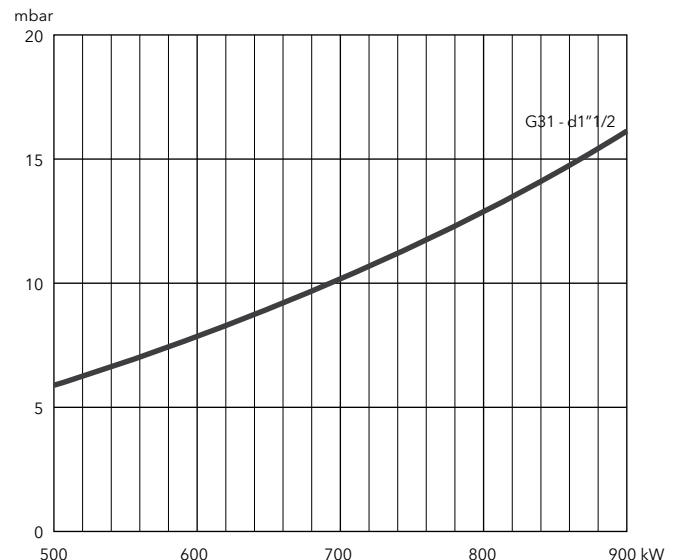



**PRESSURE LOSS [BURNER HEAD + GAS TRAIN] (mbar)**

**VGL5.1000 M V**

Burner output (kW)	Natural gas G20 Hi = 10,35 kWh/m <sup>3</sup>					Natural gas G25 Hi = 8,83 kWh/m <sup>3</sup>					LPG G31
	d3/4-Rp1"1/4	d1"1/2-Rp2"	d2"-Rp2"	d65-DN65	s65-DN65	d3/4-Rp1"1/4	d1"1/2-Rp2"	d2"-Rp2"	d65-DN65	s65-DN65	d1"1/2-Rp2"
700	40	16	12	10	10	60	21	14	10	12	10
800	53	20	14	13	13	79	27	17	13	15	12
900	68	25	17	16	16	100	34	21	16	19	15
1000	84	31	21	20	20	126	42	26	20	24	18
1100	103	37	25	24	24	154	50	31	24	29	22
1200	123	44	29	29	29	186	59	36	29	34	26

**Natural gas G20**

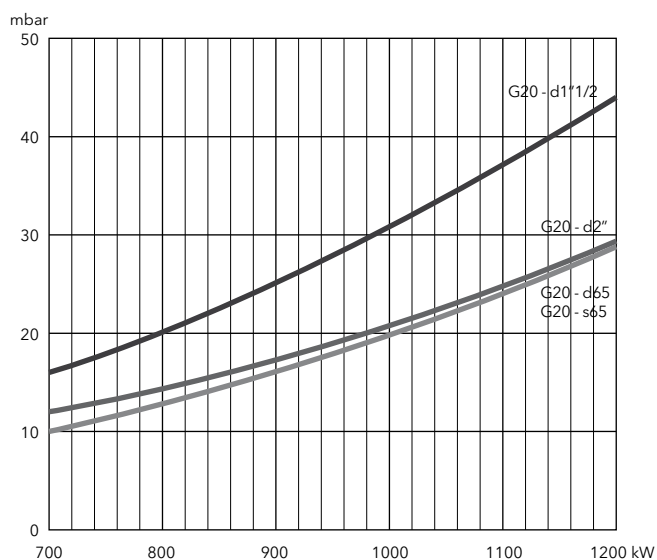

**Natural gas G25**

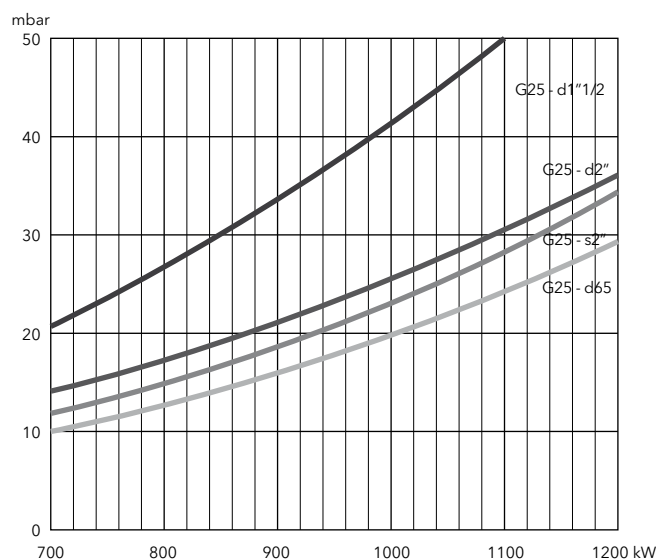

**Natural gas G20, G25**

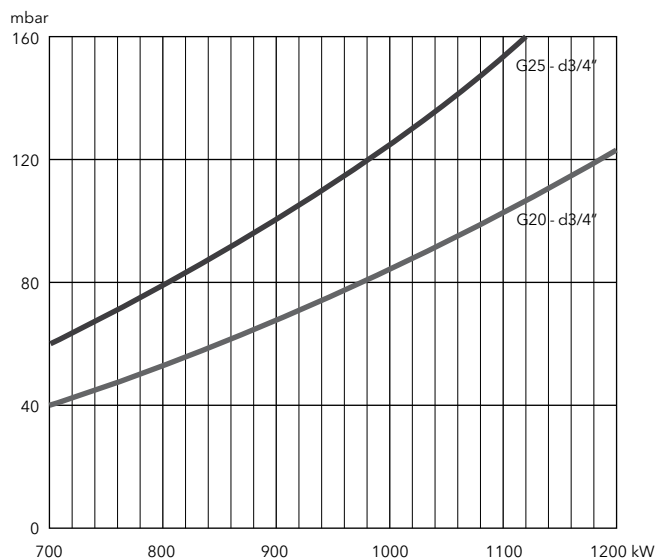

**LPG**

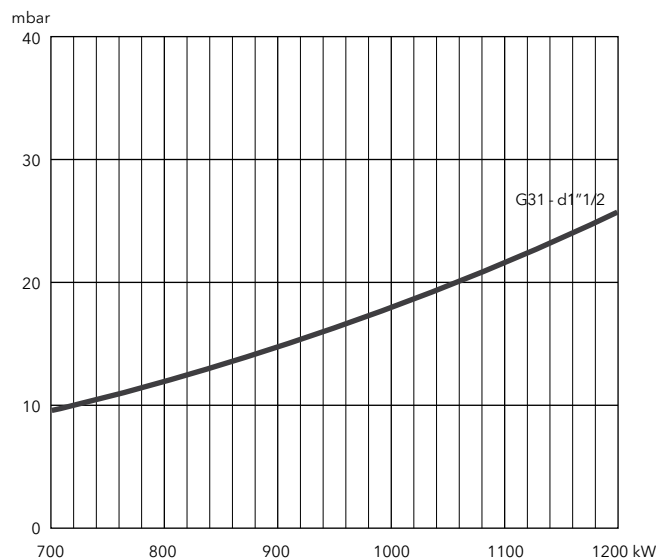

## VGL6.1600 M V, VGL6.2100 M V

300 ... 2050 kW

2 stage progressive/modulating electronic (Low NOx Class 3) / 3 stages in oil + fan speed control

- **Fuels:** natural gas (G20/G25,  $H_u = 8,83...10,35 \text{ kWh/m}^3$ );  
light oil (viscosity  $6 \text{ mm}^2/\text{s}$  at  $20^\circ\text{C}$ ,  $H_u = 11,86 \text{ kWh/kg}$ )
- **Emissions:** Low NOx class 3 in gas ( $\leq 80 \text{ mg/kWh}$ ) according to EN676  
Low NOx class 2 in light oil ( $\leq 185 \text{ mg/kWh}$ ) according to EN267
- **Operation:** two stage progressive or modulating with the installation of a power regulator and dedicated probes (see pag. 180) in gas and three stages in light oil
- **Protection level:** IP 41



### TECHNICAL DATA

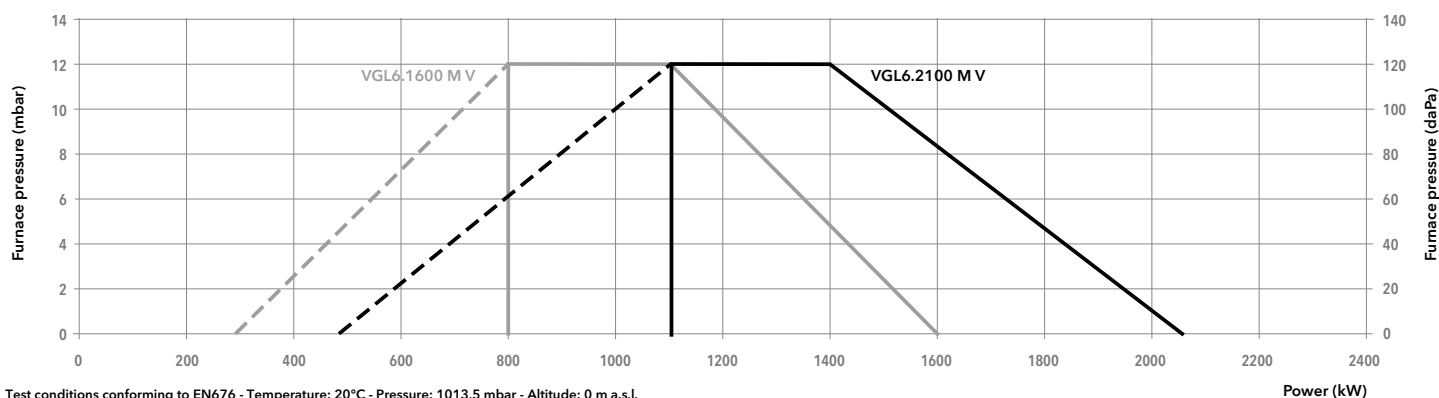

Model	VGL6.1600 M V /TC			VGL6.2100 M V /TC			
Operation range	(300) 800 - 1600 kW			(480) 1100 - 2050 kW			
Gas pressure	20 - 300 mbar			20 - 300 mbar			
Control box / flame detection	BT3... / QRA 2			BT3... / QRA 2			
Fan motor	230/400 V - 50 Hz - 2,2 kW			230/400 V - 50 Hz - 2,7 kW			
Electrical consumption	2800 W			3400 W			
Acoustic level (LpA)	77,2 dB(A)			79 dB(A)			
CE certificate	1312 BM 3427			1312 BM 3428			
Head lenght	KN	KL	KM	KN	KL	KM	
Complete	VGD 40-065 s65-DN65/TC	3836717	3836719	3836718	3836729	3836731	3836730
burner code	MBC1900 d65-DN65/TC	3836720	3836722	3836721	3836732	3836734	3836733
	MBC1200 d2"-Rp2"/TC	3836723	3836725	3836724	3836735	3836737	3836736
	MBC700 d1"1/2-Rp2"/TC	3836726	3836728	3836727	3836738	3836740	3836739

### OTHER AVAILABLE VERSIONS

Versions for continuous ventilation and post-ventilation

### SCOPE OF SUPPLY

The burner is delivered in its package complete with:

- 1 burner head with flange seal and securing screws
- 1 compact gas train with gas filter; the gas filter is built-in for threaded valves (up to 2") and separated for flanged ones (DN65/80/100)
- 1 bag containing installation fittings
- 1 bag containing technical documentation (instruction manual, technical data, electrical diagram, exploded view and spare parts list)



DIMENSIONS (mm)

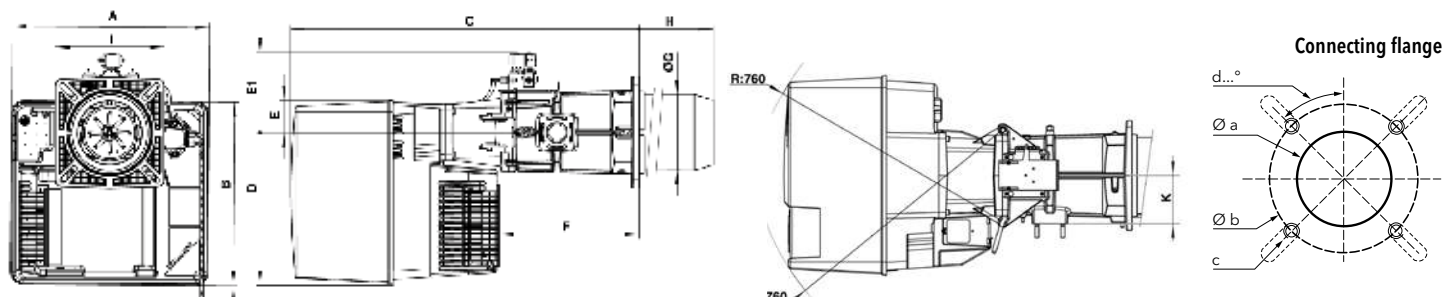

A	B	C	D	E	E1	F	ØG	H			I	K	N
								KN	KM	KL			
592	553	1050	456	97	239	421	227	270	370	470	326x335	144	247

Øa (mm)	b (mm)	c	d
250	300-400	M12	45°

Gas trains

Gas train "d":

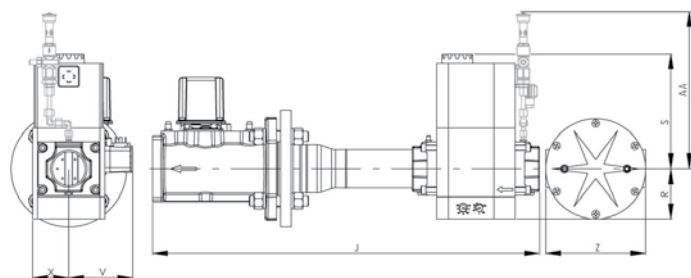

Model	J	R	S	V	X	Z	AA*
d65-DN65	490	183	245	110	98	290	385
d2"-Rp2"	700	96	330	125	81	-	385
d1"1/2-Rp2"	622	80	185	102	57	-	320

Gas train "s":

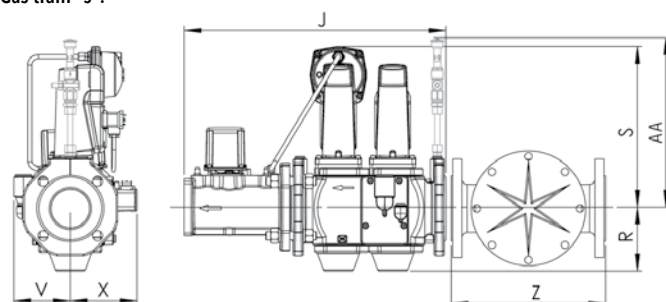

Model	J	R	S	V	X	Z	AA*
s65-DN65	490	118	300	106	126	290	365

\*: for PED configuration

PACKAGING

The burner is delivered on a pallet in 3 packages containing:

- burner housing
- combustion head
- gas train and filter

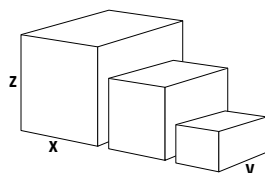

Component		Dimensions (mm)			Gross weight (kg)
		X	Y	Z	
Burner body	VGL6.1600 M V	1200	800	1440	140
	VGL6.2100 M V	1200	800	1440	140
Combustion head	KN	800	380	240	28
	KL	1000	380	420	30
	KM	1000	380	420	31
Gas train	s65-DN65/TC	670	530	380	26
	d65-DN65/TC	670	530	380	17
	d2"-Rp2"/TC	670	530	380	12
	d1"1/2-Rp2"/TC	670	530	380	12

## VGL6.1600 M V, VGL6.2100 M V

300 ... 2050 kW

2 stage progressive/modulating electronic (Low NOx Class 3) / 3 stages in oil + fan speed control

### PRESSURE LOSS [BURNER HEAD + GAS TRAIN] (mbar)

#### VGL6.1600 M V

Burner output (kW)	Natural gas G20 Hi = 10,35 kWh/m <sup>3</sup>				Natural gas G25 Hi = 8,83 kWh/m <sup>3</sup>				LPG G31 Hi = 25,89 kWh/m <sup>3</sup>
	d1"1/2-Rp2"	d2"-Rp2"	d65-DN65	s65-DN65	d1"1/2-Rp2"	d2"-Rp2"	d65-DN65	s65-DN65	d1"1/2-Rp2"
800	16	9	6	6	22	12	8	8	8
1000	25	13	10	9	34	18	12	12	12
1200	35	18	14	13	48	24	18	18	17
1400	47	24	19	18	64	32	24	24	22
1600	61	31	25	23	83	42	31	31	29

#### Natural gas G20

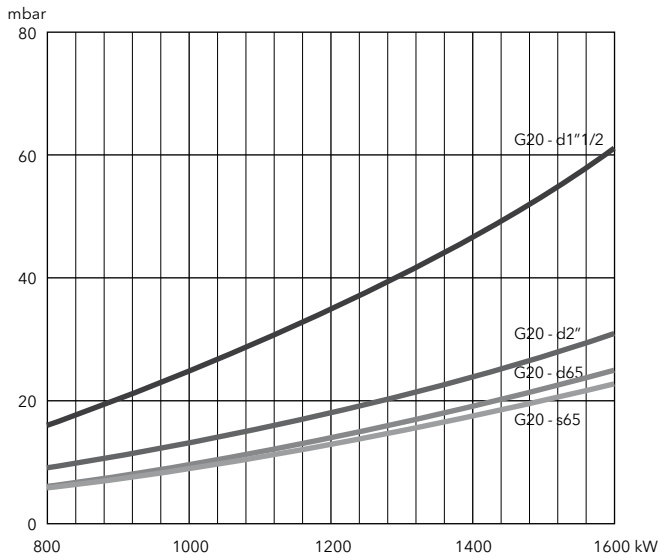

#### Natural gas G25

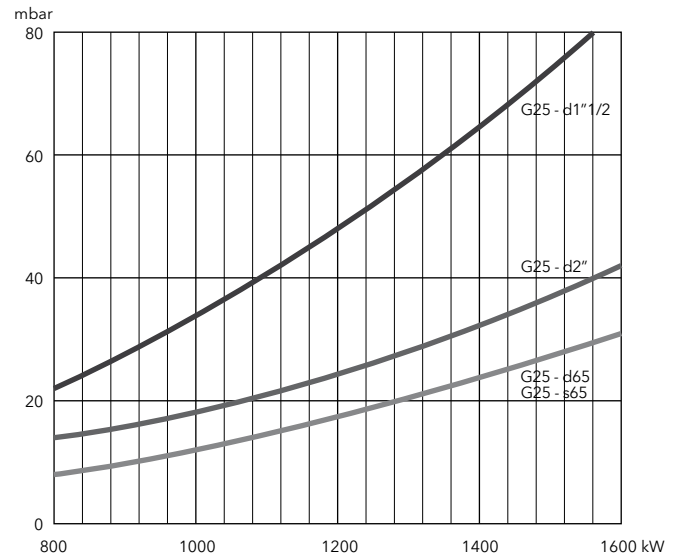

#### LPG

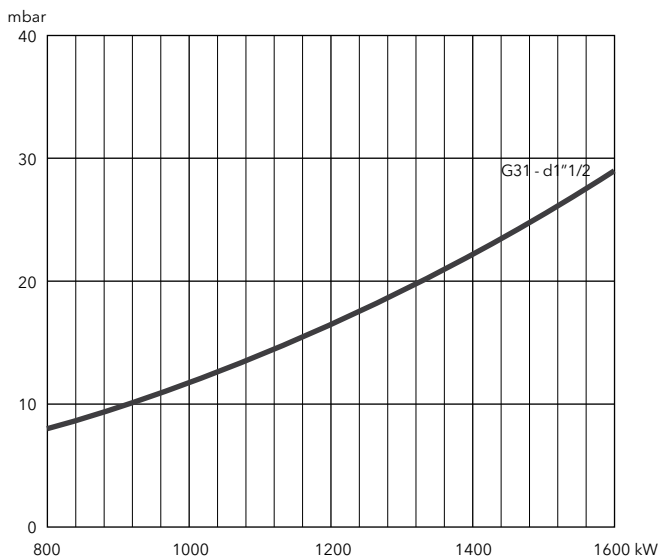





**PRESSURE LOSS [BURNER HEAD + GAS TRAIN] (mbar)**

**VGL6.2100 M V**

Burner output (kW)	Natural gas G20 Hi = 10,35 kWh/m <sup>3</sup>				Natural gas G25 Hi = 8,83 kWh/m <sup>3</sup>				LPG G31 Hi = 25,89 kWh/m <sup>3</sup>	
	d1"1/2-Rp2"	d2"-Rp2"	d65-DN65	s65-DN65	d1"1/2-Rp2"	d2"-Rp2"	d65-DN65	s65-DN65	d1"1/2-Rp2"	d2"-Rp2"
1100	28	15	12	11	39	21	15	15	13	9
1300	39	21	16	16	54	29	21	22	18	11
1500	51	27	21	21	71	37	28	29	23	14
1700	64	34	27	27	91	47	36	37	29	17
1900	80	41	34	34	114	59	45	46	36	20

**Natural gas G20**

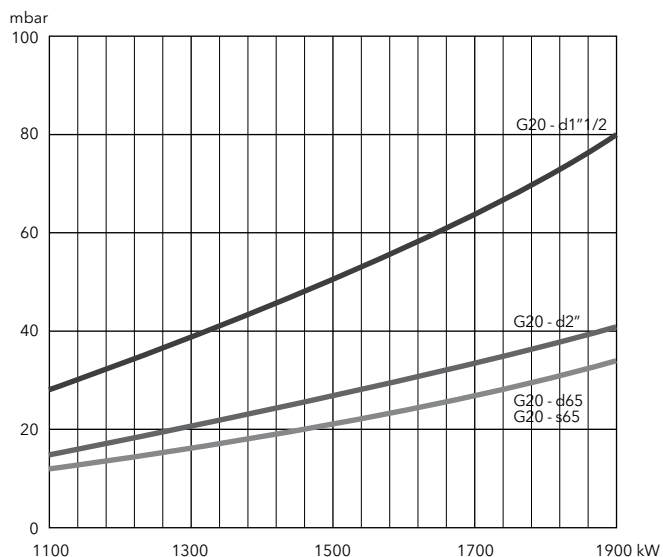

**Natural gas G25**

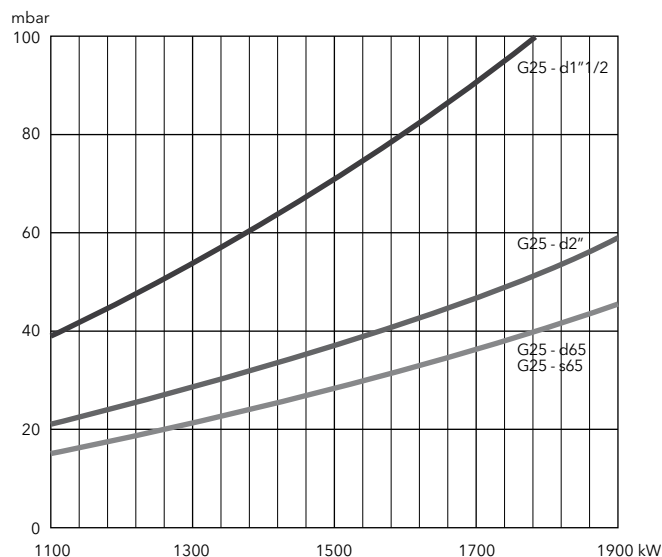

**LPG**

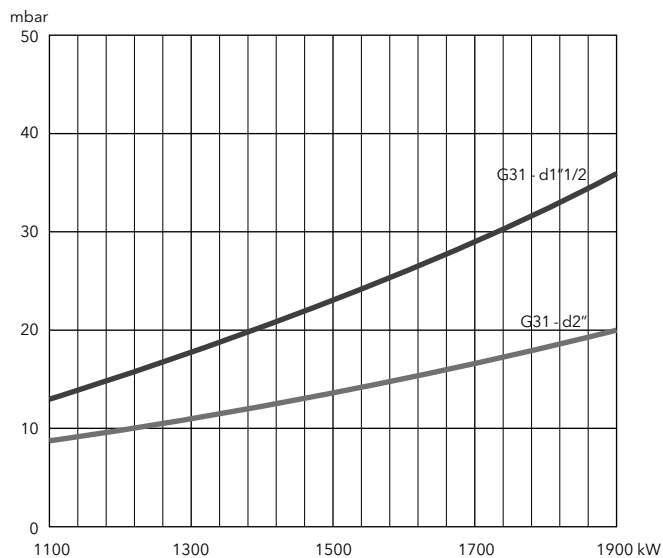

## VE1.34, VE1.50, VE1.75

16 ... 75 kW

1 stage (Yellow flame, ErP compliant)

- **Fuel:** light oil (viscosity 6 mm<sup>2</sup>/s at 20°C, H<sub>u</sub> = 11,86 kWh/kg)
- **Emissions:** compliant with ErP Directive
- **Protection level:** IP 21



### TECHNICAL DATA

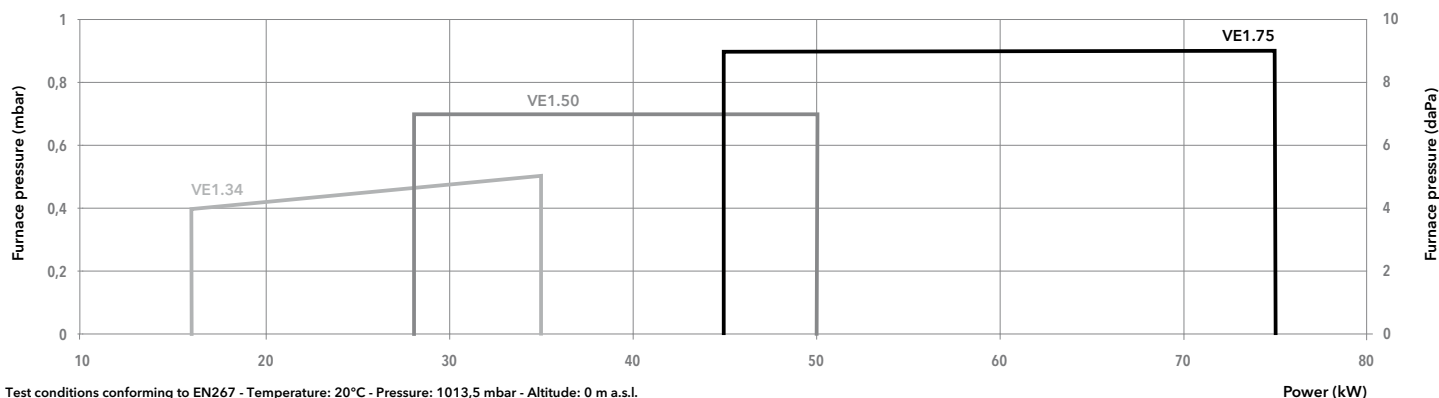

Model	VE1.34	VE1.50	VE1.75
Operation range	16 - 34 kW	28 - 50 kW	44 - 75 kW
Fuel flow	1,3 - 2,8 kg/h	2,4 - 4,2 kg/h	3,7 - 6,3 kg/h
Nozzle	0,45 US gal/h 45°S	0,75 US gal/h 45°S	1,10 US gal/h 45°H
Control box / flame detection	TCH 141.03 / QRB1	TCH 141.03 / QRB1	TCH 141.00 / QRB1
Fan motor	230 V - 50 Hz - 110 W	230 V - 50 Hz - 110 W	230 V - 50 Hz - 110 W
Electrical consumption	244 W	244 W	233 W
Flexible hoses	Rp 3/8" / M14 x 1,5 - 1000 mm	Rp 3/8" / M14 x 1,5 - 1000 mm	Rp 3/8" / M14 x 1,5 - 1000 mm
Acoustic level (LpA)	56 dB(A)	56 dB(A)	56 dB(A)
Head lenght	KN	KN	KN
Complete burner code	<b>3832630</b>	<b>3832632</b>	<b>3832634</b>

### OTHER AVAILABLE VERSIONS

Versions for continuous ventilation and post-ventilation

### SCOPE OF SUPPLY

The burner is delivered in its package complete with:

- 1 setting template
- 1 burner flange with insulation
- 1 bag containing installation fittings
- 1 bag containing technical documentation (instruction manual, technical data, electrical diagram, exploded view and spare parts list)



**DIMENSIONS (mm)**

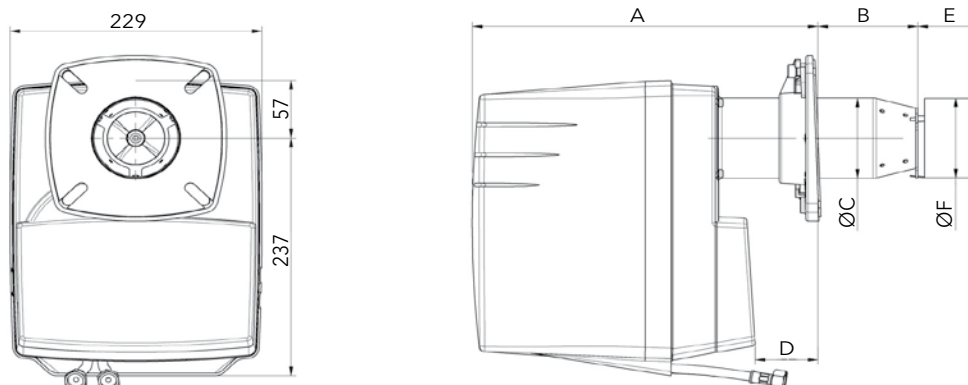

	A	B	ØC	D	E	ØF
<b>VE1.34</b>	264 ... 329	70 ... 135	80	12 ... 77	63	79
<b>VE1.50</b>	264 ... 344	70 ... 150	90	12 ... 92	56	84
<b>VE1.75</b>	297 ... 357	70 ... 138	90	15 ... 83	56	84

**Connecting flange**

Øa (mm)	b (mm)	c	d
95-104	150-170	M8	45°

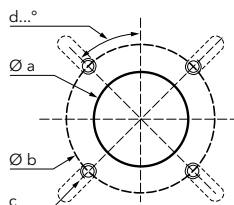

**PACKAGING**

The burner is delivered in 1 single package containing all components

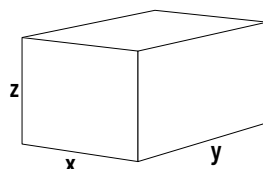

Burner	Dimensions (mm)			Gross weight (kg)
	X	Y	Z	
<b>VE1.34</b>	300	260	650	11
<b>VE1.50</b>	300	260	650	11
<b>VE1.75</b>	300	260	650	12

## VE2.100 D, VE2.150 D

50 ... 150 kW

2 stages (Yellow flame, ErP compliant)

- **Fuel:** light oil (viscosity 6 mm<sup>2</sup>/s at 20°C, H<sub>u</sub> = 11,86 kWh/kg)
- **Emissions:** compliant with ErP Directive
- **Protection level:** IP 21



### TECHNICAL DATA

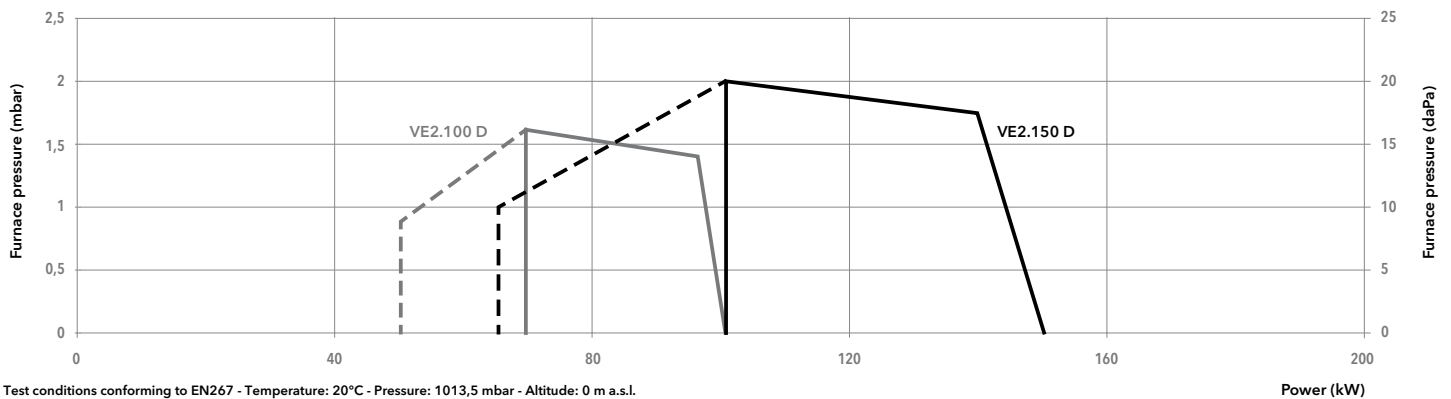

Model	VE2.100 D	VE2.150 D
Operation range	(50) 70 - 100 kW	(65) 100 - 150 kW
Fuel flow	(4,2) 5,9 - 8,4 kg/h	(5,5) 8,4 - 12,6 kg/h
Nozzle	1,25 US gal/h 45°H	2,00 US gal/h 45°H
Control box / flame detection	TCH2... / QRB1	TCH2... / QRB1
Fan motor	230 V - 50 Hz - 130 W	230 V - 50 Hz - 130 W
Electrical consumption	325 W	325 W
Flexible hoses	Rp 3/8" / DN6 x 1,5 - 1500 mm	Rp 3/8" / DN6 x 1,5 - 1500 mm
Acoustic level (LpA)	66,5 dB(A)	66,5 dB(A)
Head lenght	KL	KL
Complete burner code	<b>3833101</b>	<b>3833102</b>

### OTHER AVAILABLE VERSIONS

Versions for continuous ventilation and post-ventilation

### SCOPE OF SUPPLY

The burner is delivered in its package complete with:

- 1 setting template
- 1 burner flange with insulation
- 1 bag containing installation fittings
- 1 bag containing technical documentation (instruction manual, technical data, electrical diagram, exploded view and spare parts list)



**DIMENSIONS (mm)**

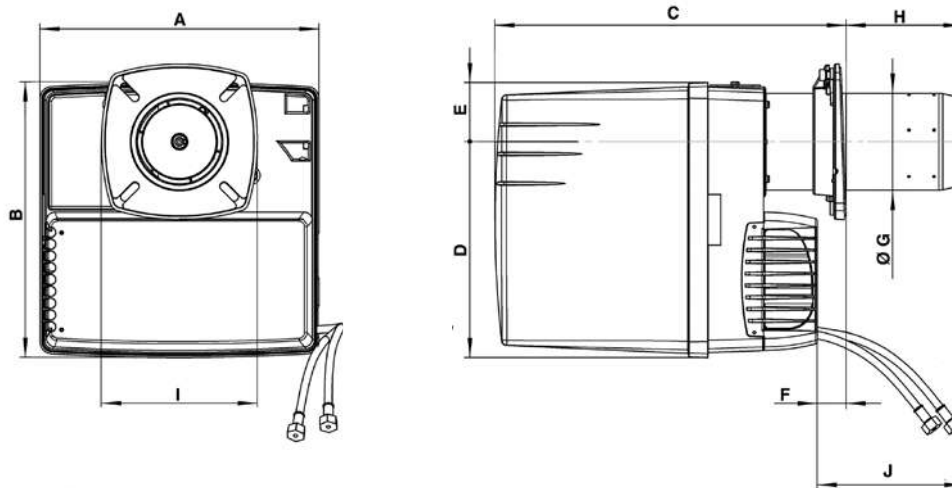

	A	B	C	D	E	F min	ØG	H max	I	J
			KL					KL		
<b>VE2.100</b>	331	326	398...638	256	133	15	115	264	185	700
<b>VE2.150</b>	331	326	398...638	256	133	15	115	264	185	700

**Connecting flange**

Øa (mm)	b (mm)	c	d
120-135	150-180	M8	45°

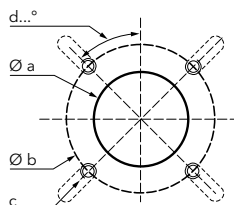

**PACKAGING**

The burner is delivered in 1 single package containing all components

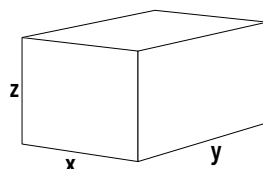

Burner	Dimensions (mm)			Gross weight (kg)
	X	Y	Z	
<b>VE2.100 D</b>	400	400	760	18
<b>VE2.150 D</b>	400	400	760	18

## VB1.20, VB1.24, VB1.28, VB1.30, VB1.35

11 ... 35 kW

1 stage (Blue flame, ErP compliant)

- **Fuel:** light oil (viscosity 6 mm<sup>2</sup>/s at 20°C, H<sub>u</sub> = 11,86 kWh/kg)
- **Emissions:** compliant with ErP Directive
- **Protection level:** IP 21



### TECHNICAL DATA

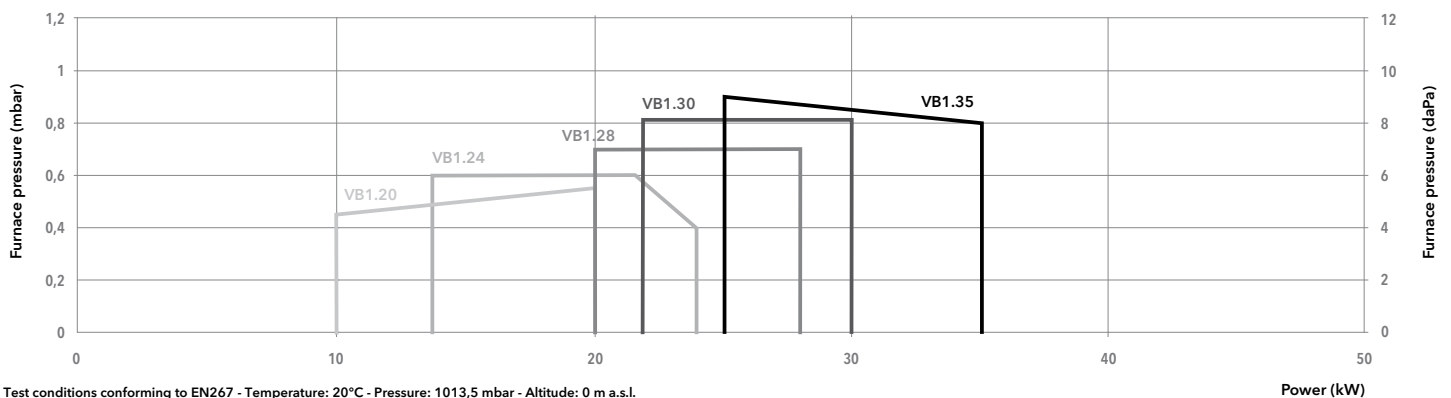

Test conditions conforming to EN267 - Temperature: 20°C - Pressure: 1013,5 mbar - Altitude: 0 m a.s.l.

Model	VB1.20	VB1.24	VB1.28	VB1.30	VB1.35
<b>Operation range</b>	11 - 20 kW	14 - 24 kW	20 - 28 kW	22 - 30 kW	25 - 35 kW
<b>Fuel flow</b>	0,9 - 1,7 kg/h	1,2 - 2,0 kg/h	1,7 - 2,4 kg/h	1,9 - 2,5 kg/h	2,1 - 3,0 kg/h
<b>Nozzle</b>	0,40 US gal/h 60°S	0,45 US gal/h 60°S	0,50 US gal/h 80°S	0,55 US gal/h 80°S	0,60 US gal/h 80°S
<b>Control box / flame detection</b>	TCH 141.03 / IRD 1010	TCH 141.03 / IRD 1010	TCH 141.03 / IRD 1010	TCH 141.03 / IRD 1010	TCH 141.03 / IRD 1010
<b>Fan motor</b>	230 V - 50 Hz - 110 W	230 V - 50 Hz - 110 W	230 V - 50 Hz - 110 W	230 V - 50 Hz - 110 W	230 V - 50 Hz - 110 W
<b>Electrical consumption</b>	207 W	207 W	207 W	207 W	207 W
<b>Flexible hoses</b>	Rp 3/8" / M14 x 1,5 - 1000 mm				
<b>Acoustic level (LpA)</b>	59 dB(A)	59 dB(A)	59 dB(A)	59 dB(A)	59 dB(A)
<b>Head lenght</b>	KN	KN	KN	KN	KN
<b>Complete burner code</b>	<b>3832624</b>	<b>3832625</b>	<b>3832626</b>	<b>3832627</b>	<b>3832628</b>

### OTHER AVAILABLE VERSIONS

Versions for continuous ventilation and post-ventilation

### SCOPE OF SUPPLY

The burner is delivered in its package complete with:

- 1 setting template
- 1 burner flange with insulation
- 1 bag containing installation fittings
- 1 bag containing technical documentation (instruction manual, technical data, electrical diagram, exploded view and spare parts list)



**DIMENSIONS (mm)**

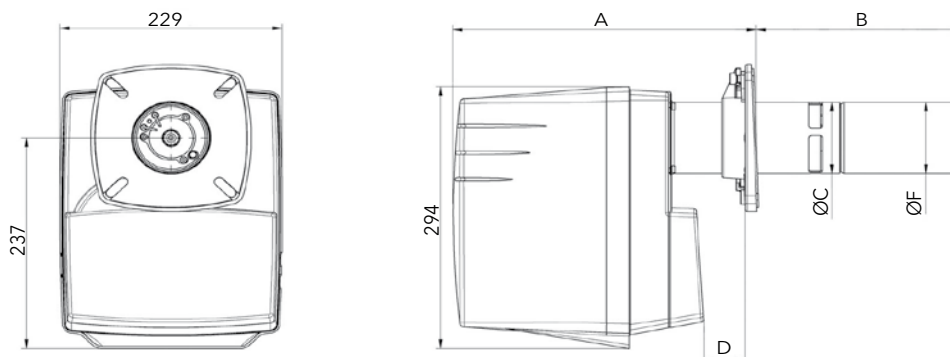

Model	A		B		ØC	D		ØF
	min	max	min	max		min	max	
VB1.20	269	284	234	249	80	12	27	80
VB1.24	269	284	234	249	80	12	27	80
VB1.28	269	284	234	249	80	12	27	100
VB1.30	269	284	244	259	80	12	27	100
VB1.35	269	284	294	309	80	12	27	120

**Connecting flange**

Øa (mm)	b (mm)	c	d
85-104	150-170	M8	45°

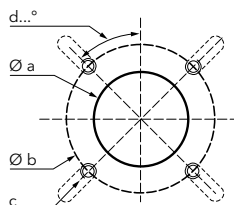

**PACKAGING**

The burner is delivered in 1 single package containing all components

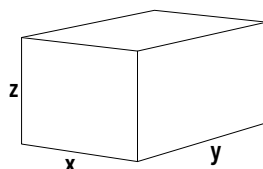

Burner	Dimensions (mm)			Gross weight (kg)
	X	Y	Z	
VB1.20	300	260	650	12
VB1.24	300	260	650	12
VB1.28	300	260	650	12
VB1.30	300	260	650	12
VB1.35	300	260	650	12

## VB2.38 VD, VB2.45 VD, VB2.54 VD, VB2.66 VD

22 ... 66 kW

2 stages (Blue flame, ErP compliant)

- **Fuel:** light oil (viscosity 6 mm<sup>2</sup>/s at 20°C, H<sub>u</sub> = 11,86 kWh/kg)
- **Emissions:** compliant with ErP Directive
- **Protection level:** IP 21



### TECHNICAL DATA

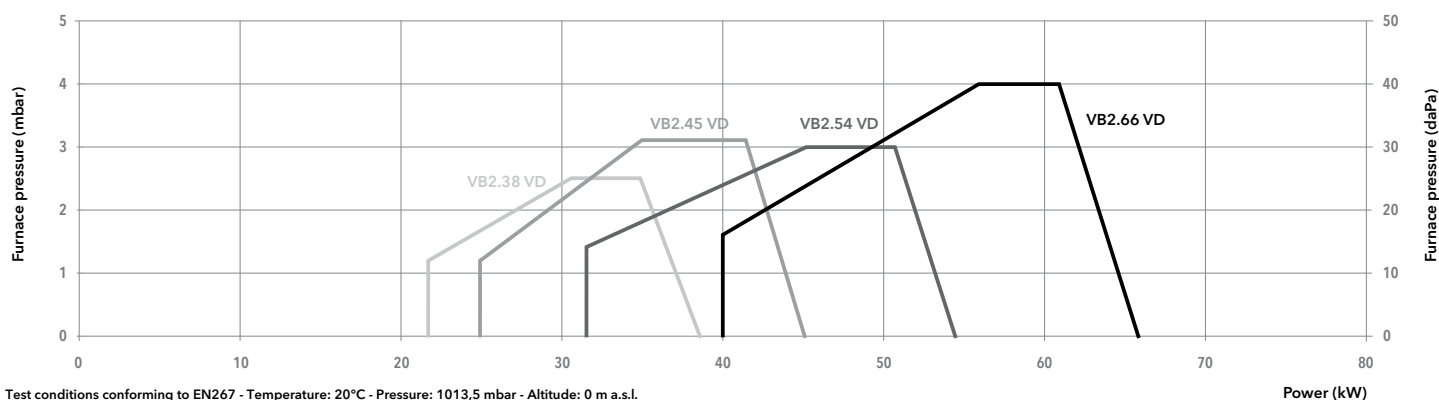

Model	VB2.38 VD	VB2.45 VD	VB2.54 VD	VB2.66 VD
Operation range	22 - 38 kW	25 - 45 kW	32 - 54 kW	40 - 66 kW
Fuel flow	1,8 - 3,2 kg/h	2,1 - 3,8 kg/h	2,7 - 4,6 kg/h	3,4 - 5,6 kg/h
Nozzle	0,55 US gal/h 80°S	0,55 US gal/h 80°S	0,65 US gal/h 80°S	1,00 US gal/h 80°S
Control box / flame detection	TCH 24x / IRD 1010	TCH 24x / IRD 1010	TCH 24x / IRD 1010	TCH 24x / IRD 1010
Fan motor	230 V - 50 Hz - 56 W	230 V - 50 Hz - 190 W	230 V - 50 Hz - 190 W	230 V - 50 Hz - 190 W
Electrical consumption	191 W	287 W	325 W	310 W
Flexible hoses	Rp 3/8" / M14 x 1,5 - 1000 mm	Rp 3/8" / M14 x 1,5 - 1000 mm	Rp 3/8" / M14 x 1,5 - 1000 mm	Rp 3/8" / M14 x 1,5 - 1000 mm
Acoustic level (LpA)	59,3 dB(A)	67,2 dB(A)	70,2 dB(A)	68,4 dB(A)
Head lenght	KN	KN	KN	KN
Complete burner code	<b>3835349</b>	<b>3835350</b>	<b>3835351</b>	<b>3835352</b>

### OTHER AVAILABLE VERSIONS

Versions for continuous ventilation and post-ventilation

### SCOPE OF SUPPLY

The burner is delivered in its package complete with:

- 1 setting template
- 1 burner flange with insulation
- 1 bag containing installation fittings
- 1 bag containing technical documentation (instruction manual, technical data, electrical diagram, exploded view and spare parts list)





**DIMENSIONS (mm)**

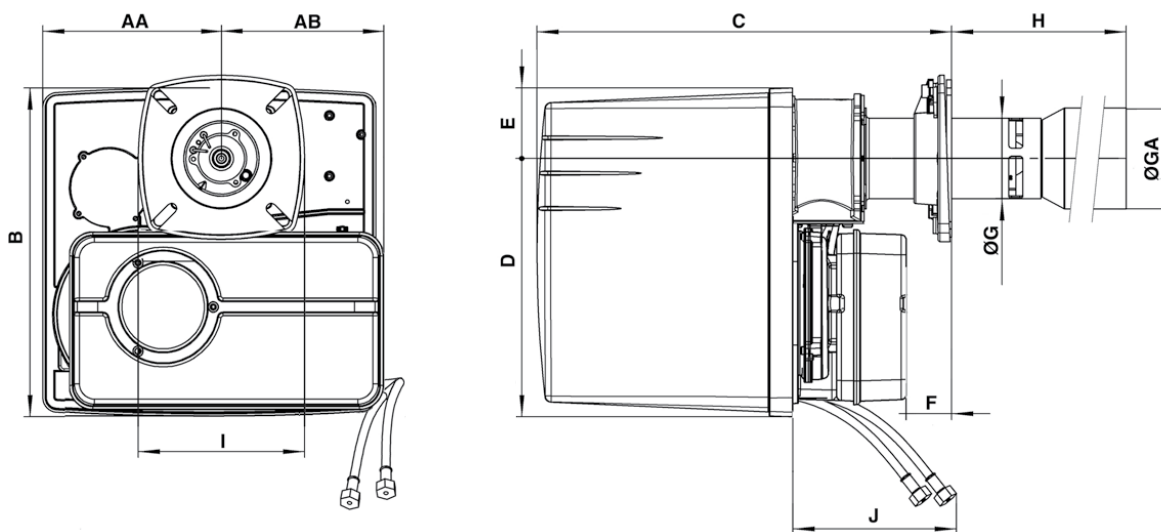

	AA	AB	B	C	D	E	F	ØG	ØGA	H	I	J
				KN						KN		
<b>VB2.38 VD</b>	178	153	325	390...450	256	69	15...75	80	100	245...185	165	1200
<b>VB2.45 VD</b>	178	153	325	390...450	256	69	15...75	80	100	245...185	165	1200
<b>VB2.54 VD</b>	178	153	325	390...450	256	69	15...75	80	100	245...185	165	1200
<b>VB2.66 VD</b>	178	153	325	390...450	256	69	15...75	100	120	300...240	185	1200

**Connecting flange**

Model	Øa (mm)	b (mm)	c	d
<b>VB2.38/45/54 VD</b>	85-104	150-170	M8	45°
<b>VB2.66 VD</b>	110-135	150-184	M8	45°

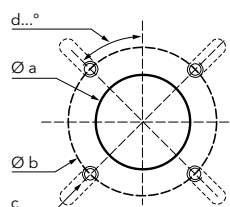

**PACKAGING**

The burner is delivered in 1 single package containing all components

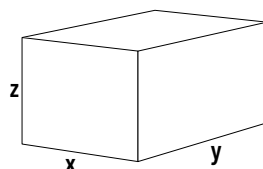

Burner	Dimensions (mm)			Gross weight (kg)
	X	Y	Z	
<b>VB2.38 VD</b>	400	400	760	17
<b>VB2.45 VD</b>	400	400	760	17
<b>VB2.54 VD</b>	400	400	760	17
<b>VB2.66 VD</b>	400	400	760	17

## VB2.77 VD, VB2.85 VD, VB2.95 VD

45 ... 95 kW

2 stages (Blue flame, ErP compliant)

- **Fuel:** light oil (viscosity 6 mm<sup>2</sup>/s at 20°C, H<sub>u</sub> = 11,86 kWh/kg)
- **Emissions:** compliant with ErP Directive
- **Protection level:** IP 21



### TECHNICAL DATA

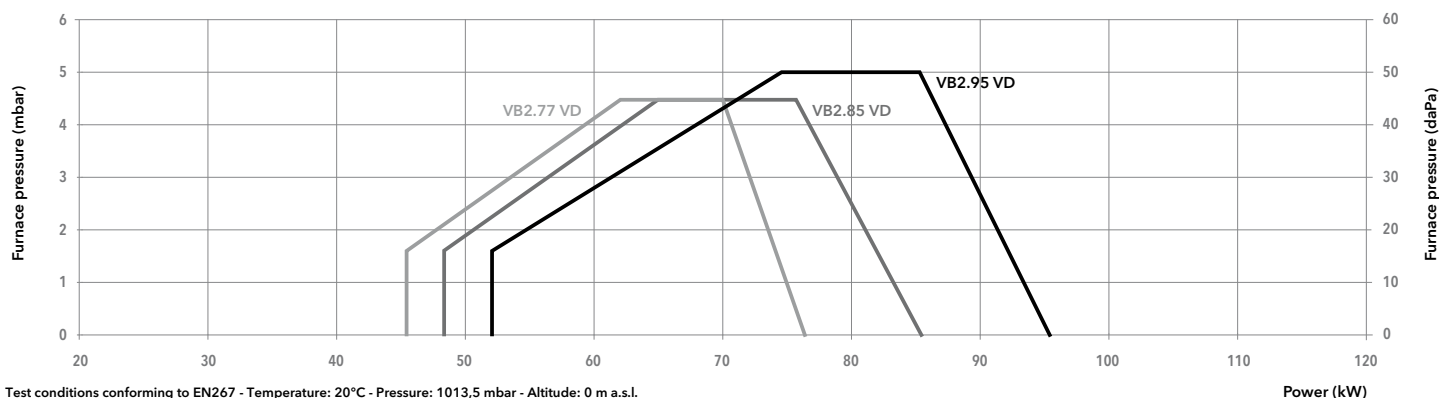

Model	VB2.77 VD	VB2.85 VD	VB2.95 VD
Operation range	45 - 77 kW	48 - 85 kW	52 - 95 kW
Fuel flow	3,8 - 6,5 kg/h	4,0 - 7,2 kg/h	4,4 - 8,0 kg/h
Nozzle	1,10 US gal/h 80°S	1,25 US gal/h 80°S	1,25 US gal/h 80°S
Control box / flame detection	TCH 24x / IRD 1010	TCH 24x / IRD 1010	TCH 24x / IRD 1010
Fan motor	230 V - 50 Hz - 190 W	230 V - 50 Hz - 190 W	230 V - 50 Hz - 190 W
Electrical consumption	276 W	285 W	262 W
Flexible hoses	Rp 3/8" / DN6 x 1,5 - 1500 mm	Rp 3/8" / DN6 x 1,5 - 1500 mm	Rp 3/8" / DN6 x 1,5 - 1500 mm
Acoustic level (LpA)	68,5 dB(A)	66,5 dB(A)	67,6 dB(A)
Head lenght	KN	KN	KN
Complete burner code	3835353	3835354	3835355

### OTHER AVAILABLE VERSIONS

Versions for continuous ventilation and post-ventilation

### SCOPE OF SUPPLY

The burner is delivered in its package complete with:

- 1 setting template
- 1 burner flange with insulation
- 1 bag containing installation fittings
- 1 bag containing technical documentation (instruction manual, technical data, electrical diagram, exploded view and spare parts list)



**DIMENSIONS (mm)**

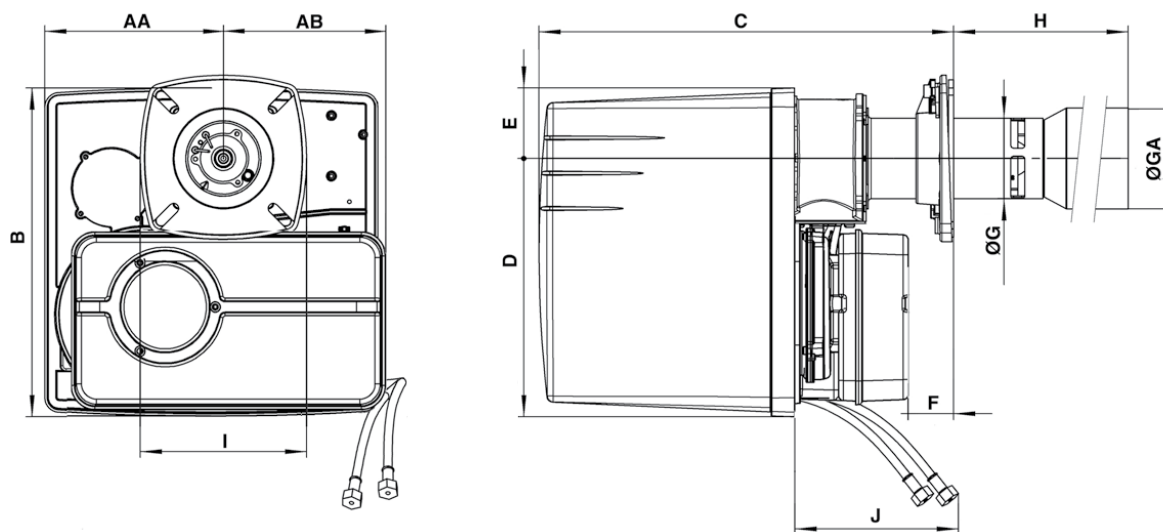

	AA	AB	B	C	D	E	F	ØG	ØGA	H	I	J
				KN						KN		
<b>VB2.77 VD</b>	178	153	325	390...450	256	69	15...75	100	120	300...240	185	1200
<b>VB2.85 VD</b>	178	153	325	390...450	256	69	15...75	100	120	300...240	185	1200
<b>VB2.95 VD</b>	178	153	325	390...450	256	69	15...75	100	120	300...240	185	1200

**Connecting flange**

Øa (mm)	b (mm)	c	d
110-135	150-184	M8	45°

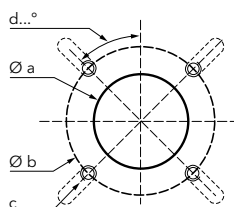

**PACKAGING**

The burner is delivered in 1 single package containing all components

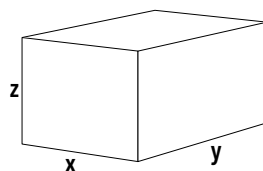

Burner	Dimensions (mm)			Gross weight (kg)
	X	Y	Z	
<b>VB2.77 VD</b>	400	400	760	17
<b>VB2.85 VD</b>	400	400	760	17
<b>VB2.95 VD</b>	400	400	760	17

## VL1.40 P, VL1.55 P, VL1.42, VL1.55, VL1.105

18 ... 105 kW

1 stage (ErP compliant)

- **Fuel:** light oil (viscosity 6 mm<sup>2</sup>/s at 20°C, H<sub>u</sub> = 11,86 kWh/kg)
- **Emissions:** compliant with ErP Directive
- **Protection level:** IP 21



### TECHNICAL DATA

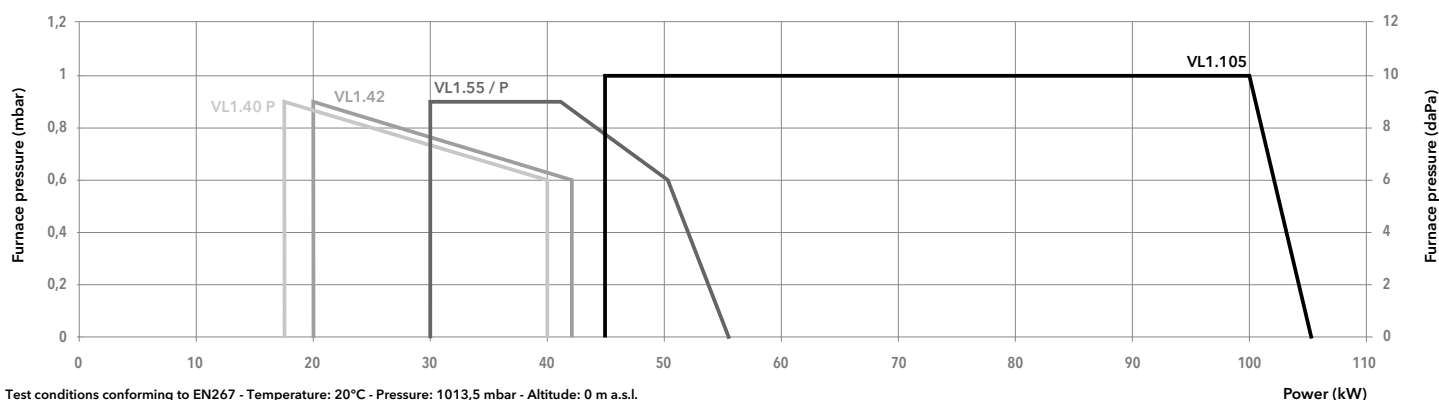

Test conditions conforming to EN267 - Temperature: 20°C - Pressure: 1013,5 mbar - Altitude: 0 m a.s.l.

Model	VL1.40 P *	VL1.55 P *	VL1.42	VL1.55	VL1.105	
Operation range	18 - 40 kW	30 - 55 kW	20 - 42 kW	30 - 55 kW	45 - 105 kW	
Fuel flow	1,5 - 3,3 kg/h	2,5 - 4,6 kg/h	1,7 - 3,5 kg/h	2,5 - 4,6 kg/h	3,8 - 8,8 kg/h	
Nozzle	0,50 US gal/h 60°S	1,00 US gal/h 45°S	0,60 US gal/h 60°S	1,00 US gal/h 45°S	1,25 US gal/h 45°S	
Control box / flame detection	TCH 141.03 / QRB1					
Fan motor	230 V - 50 Hz - 110 W					
Electrical consumption	244 W	244 W	195 W	195 W	240 W	
Flexible hoses	Rp 3/8" / M14 x 1,5 - 1000 mm					
Acoustic level (LpA)	55 dB(A)	55 dB(A)	55 dB(A)	55 dB(A)	60,5 dB(A)	
Head lenght	KN	KN	KN	KN	KN	KL
Complete burner code	3832615	3833026	3832616	3832617	3836898	3836899

\*: pre-heater

### OTHER AVAILABLE VERSIONS

Versions for continuous ventilation and post-ventilation

### SCOPE OF SUPPLY

The burner is delivered in its package complete with:

- 1 burner flange with insulation
- 1 bag containing installation fittings
- 1 bag containing technical documentation (instruction manual, technical data, electrical diagram, exploded view and spare parts list)



**DIMENSIONS (mm)**

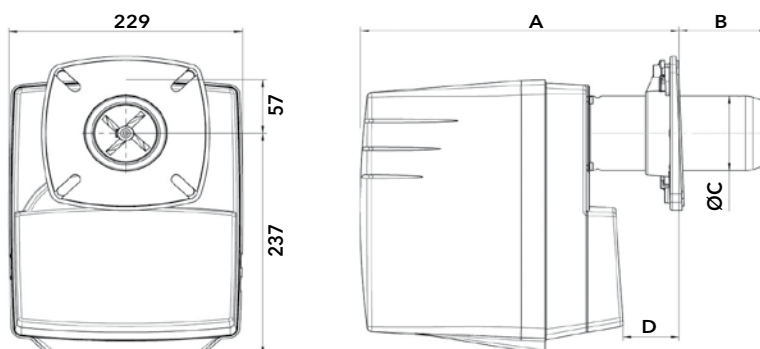

	A		B			ØC	D	
	min	max	min	KN max	KL max		min	max
<b>VL1.40 P</b>	270	310	70	120	-	80	21	71
<b>VL1.42</b>	270	310	70	120	-	80	21	71
<b>VL1.55</b>	270	310	70	120	-	80	21	71
<b>VL1.55 P</b>	270	310	70	120	-	80	21	71
<b>VL1.105</b>	297	357	70	138	200	90	15	83

**Connecting flange**

Model	Øa (mm)	b (mm)	c	d
<b>VL1.40/55</b>	85-104	150-170	M8	45°
<b>VL1.105</b>	95-104	150-170	M8	45°

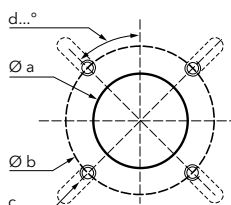

**PACKAGING**

The burner is delivered in 1 single package containing all components

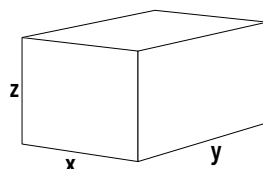

Burner	Dimensions (mm)			Gross weight (kg)
	X	Y	Z	
<b>VL1.40 P</b>	300	260	650	11
<b>VL1.42</b>	300	260	650	11
<b>VL1.55</b>	300	260	650	11
<b>VL1.55 P</b>	300	260	650	11
<b>VL1.105</b>	300	260	650	12

## VL2.140, VL2.200

80 ... 200 kW

1 stage (ErP compliant)

- **Fuel:** light oil (viscosity 6 mm<sup>2</sup>/s at 20°C, H<sub>u</sub> = 11,86 kWh/kg)
- **Emissions:** compliant with ErP Directive
- **Protection level:** IP 21



### TECHNICAL DATA

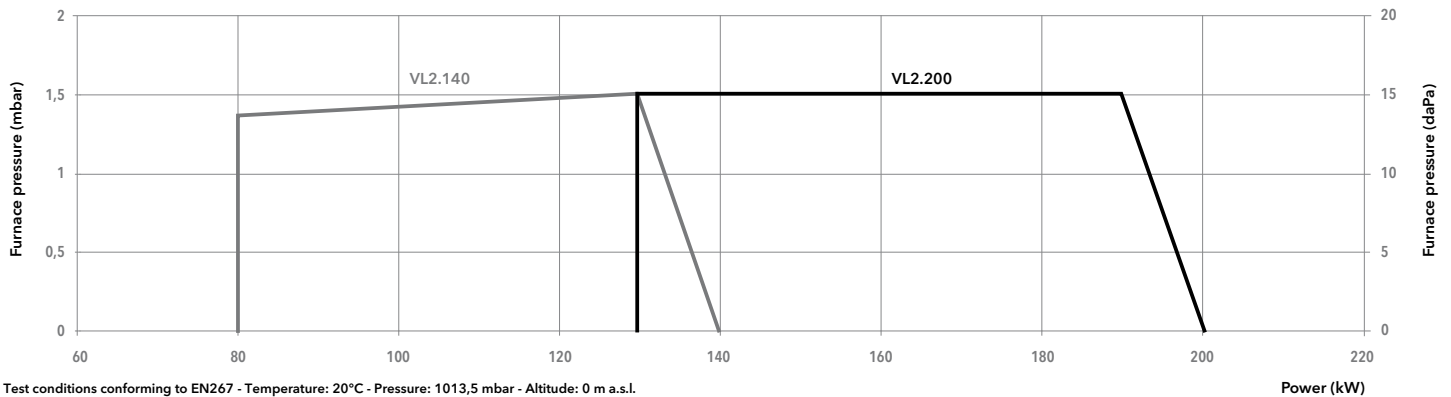

Test conditions conforming to EN267 - Temperature: 20°C - Pressure: 1013,5 mbar - Altitude: 0 m a.s.l.

Model	VL2.140		VL2.200	
Operation range	80 - 140 kW		130 - 200 kW	
Fuel flow	6,7 - 11,8 kg/h		11 - 16,9 kg/h	
Nozzle	2,25 US gal/h 45°S		3,50 US gal/h 45°S	
Control box / flame detection	TCH1... / QRB1		TCH1... / QRB1	
Fan motor	230 V - 50 Hz - 160 W		230 V - 50 Hz - 130 W	
Electrical consumption	274 W		290 W	
Flexible hoses	Rp 3/8" / DN6 x 1,5 - 1500 mm		Rp 3/8" / DN6 x 1,5 - 1500 mm	
Acoustic level (LpA)	62 dB(A)		65 dB(A)	
Head lenght	KN	KL	KN	KL
Complete burner code	3833536	3833537	3833540	3833541

### OTHER AVAILABLE VERSIONS

Versions for continuous ventilation and post-ventilation

### SCOPE OF SUPPLY

The burner is delivered in its package complete with:

- 2 oil hoses
- 1 burner flange with insulation
- 1 bag containing installation fittings
- 1 bag containing technical documentation (instruction manual, technical data, electrical diagram, exploded view and spare parts list)



**DIMENSIONS (mm)**

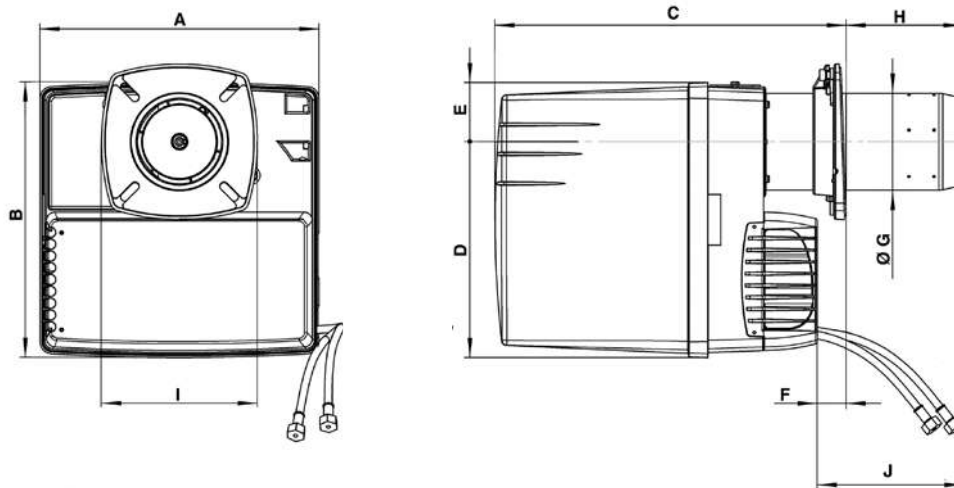

	A	B	C		D	E	F min	ØG	H		I	J
			KN	KL					KN	KL		
<b>VL2.140</b>	331	325	398...518	398...638	256	69	15	100	30...150	30...270	185	1200
<b>VL2.200</b>	331	325	398...518	398...638	256	69	15	100	30...150	30...270	185	1200

**Connecting flange**

Øa (mm)	b (mm)	c	d
120-135	150-184	M8	45°

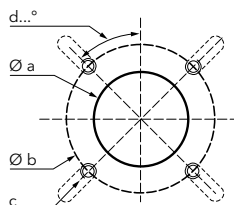

**PACKAGING**

The burner is delivered in 1 single package containing all components

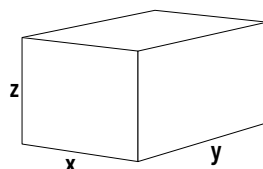

Burner	Dimensions (mm)			Gross weight (kg)
	X	Y	Z	
<b>VL2.140</b>	400	400	760	18
<b>VL2.200</b>	400	400	760	18

## VL2.120 D, VL2.160 D, VL2.210 D

60 ... 210 kW  
2 stages (ErP compliant)

- **Fuel:** light oil (viscosity 6 mm<sup>2</sup>/s at 20°C, H<sub>u</sub> = 11,86 kWh/kg)
- **Emissions:** compliant with ErP Directive
- **Protection level:** IP 21



### TECHNICAL DATA

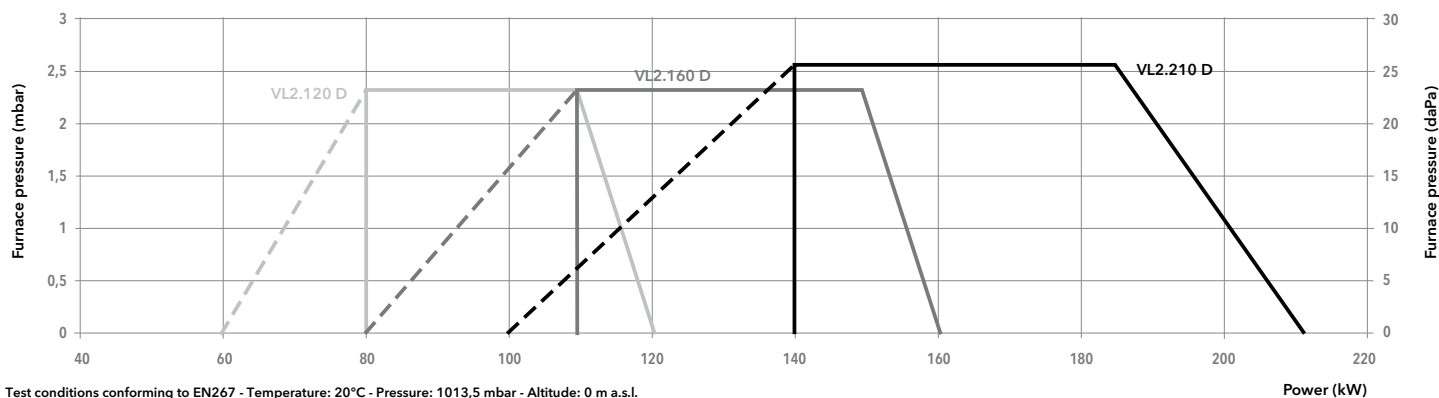

Model	VL2.120 D		VL2.160 D		VL2.210 D	
Operation range	(60) 80 - 120 kW		(80) 110 - 160 kW		(100) 140 - 210 kW	
Fuel flow	4,6 - 10,0 kg/h		6,1 - 13,5 kg/h		8,4 - 17,7 kg/h	
Nozzles	1,50 US gal/h 45°S		2,25 US gal/h 45°S		2,75 US gal/h 45°S	
Control box / flame detection	TCH 2... / QRB1		TCH 2... / QRB1		TCH 2... / QRB1	
Fan motor	230 V - 50 Hz - 160 W		230 V - 50 Hz - 160 W		230 V - 50 Hz - 130 W	
Electrical consumption	216 W		290 W		345 W	
Flexible hoses	Rp 3/8" / M14 x 1,5 - 1500 mm		Rp 3/8" / M14 x 1,5 - 1500 mm		Rp 3/8" / M14 x 1,5 - 1500 mm	
Acoustic level (LpA)	62 dB(A)		64 dB(A)		65 dB(A)	
Head lenght	KN	KL	KN	KL	KN	KL
Complete burner code	3833344	3833345	3833346	3833347	3833348	3833349

### OTHER AVAILABLE VERSIONS

Versions for continuous ventilation and post-ventilation

### SCOPE OF SUPPLY

The burner is delivered in its package complete with:

- 1 setting template
- 1 burner flange with insulation
- 1 bag containing installation fittings
- 1 bag containing technical documentation (instruction manual, technical data, electrical diagram, exploded view and spare parts list)





**DIMENSIONS (mm)**

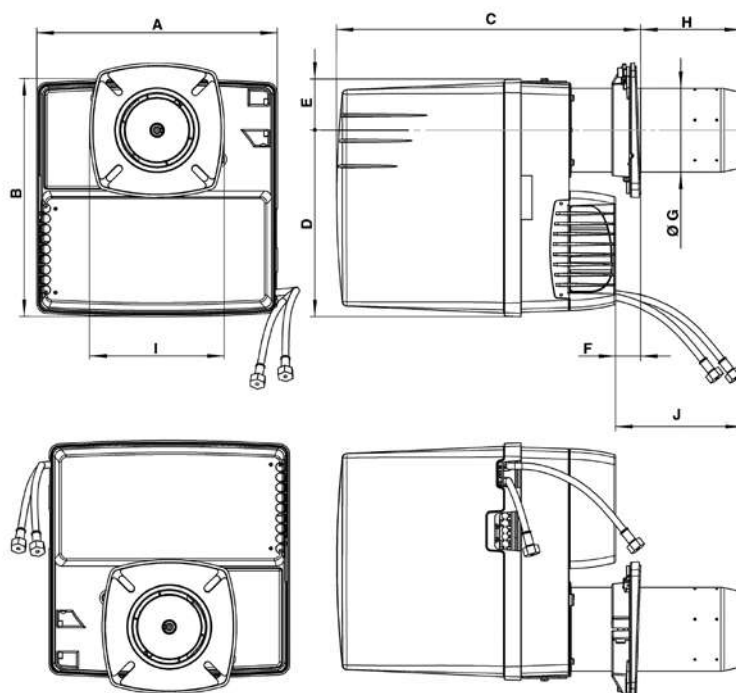

A	B	C		D	E	F min	ØG	H		I	J
		KN	KL					KN	KL		
331	326	398...518	398...638	256	69	15	115	30...150	30...270	185x185	1200

**Connecting flange**

Øa (mm)	b (mm)	c	d
120-135	150-184	M8	45°

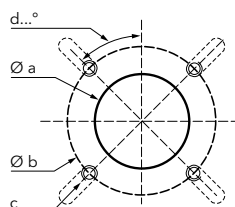

**PACKAGING**

The burner is delivered in 1 single package containing all components

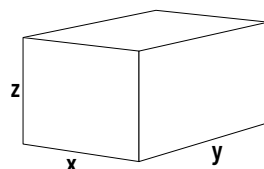

Burner	Dimensions (mm)			Gross weight (kg)
	X	Y	Z	
<b>VL2.120 D</b>	400	400	770	18
<b>VL2.160 D</b>	400	400	770	18
<b>VL2.210 D</b>	400	400	770	19

## VL3.290 D, VL3.360 D, VL4.440 D

130 ... 360 kW  
2 stages (ErP compliant)

- **Fuel:** light oil (viscosity 6 mm<sup>2</sup>/s at 20°C, H<sub>u</sub> = 11,86 kWh/kg)
- **Emissions:** compliant with ErP Directive
- **Protection level:** IP 41



### TECHNICAL DATA

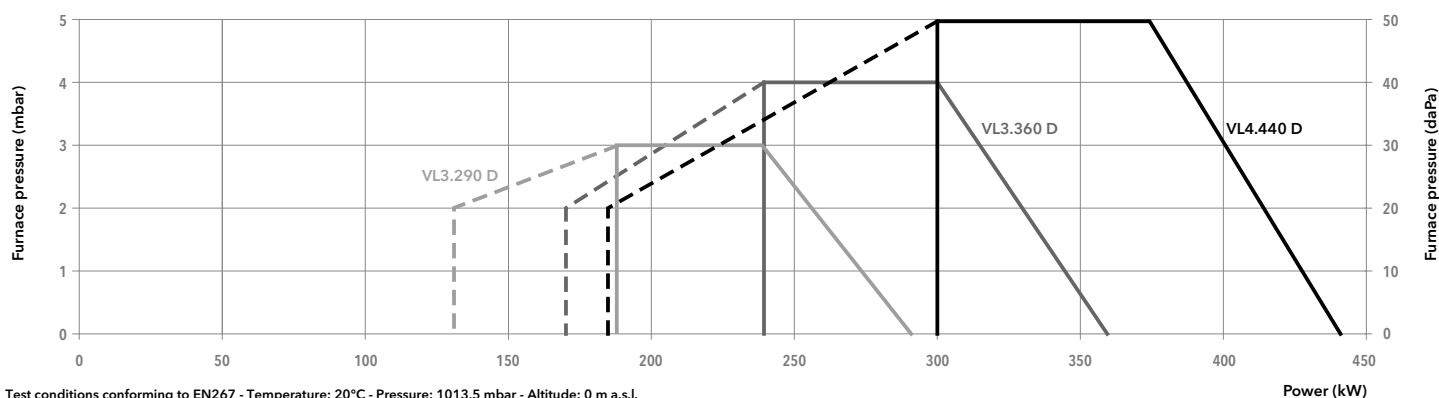

Model	VL3.290 D		VL3.360 D		VL4.440 D	
Operation range	(130) 185 - 290 kW		(170) 240 - 360 kW		(180) 300 - 440 kW	
Fuel flow	15,6 - 24,4 kg/h		20,2 - 30,3 kg/h		25,3 - 37,0 kg/h	
Nozzles	3,75 US gal/h 60°B		4,50 US gal/h 60°B		5,00 US gal/h 60°S / 3,5 US gal/h 60°S	
Control box / flame detection	TCH2... / QRB1		TCH2... / QRB1		TCH2... / MZ 770 S	
Fan motor	230 V - 50 Hz - 250 W		230 V - 50 Hz - 300 W		230 V - 50 Hz - 750 W	
Electrical consumption	445 W		540 W		27 + 785 W	
Flexible hoses	Rp 3/8" / DN6 x 1500 mm		Rp 3/8" / DN6 x 1500 mm		Rp 3/8" / DN6 x 1500 mm	
Acoustic level (LpA)	67 dB(A)		69 dB(A)		70 dB(A)	
Head lenght	KN	KL	KN	KL	KN	KL
Complete burner code	3833072	3833073	3833070	3833071	3836614	3836615

### OTHER AVAILABLE VERSIONS

Versions for continuous ventilation and post-ventilation

### SCOPE OF SUPPLY

The burner is delivered in its package complete with:

- 1 burner head with flange seal and securing screws
- 1 bag containing installation fittings
- 1 bag containing technical documentation (instruction manual, technical data, electrical diagram, exploded view and spare parts list)



**DIMENSIONS (mm)**

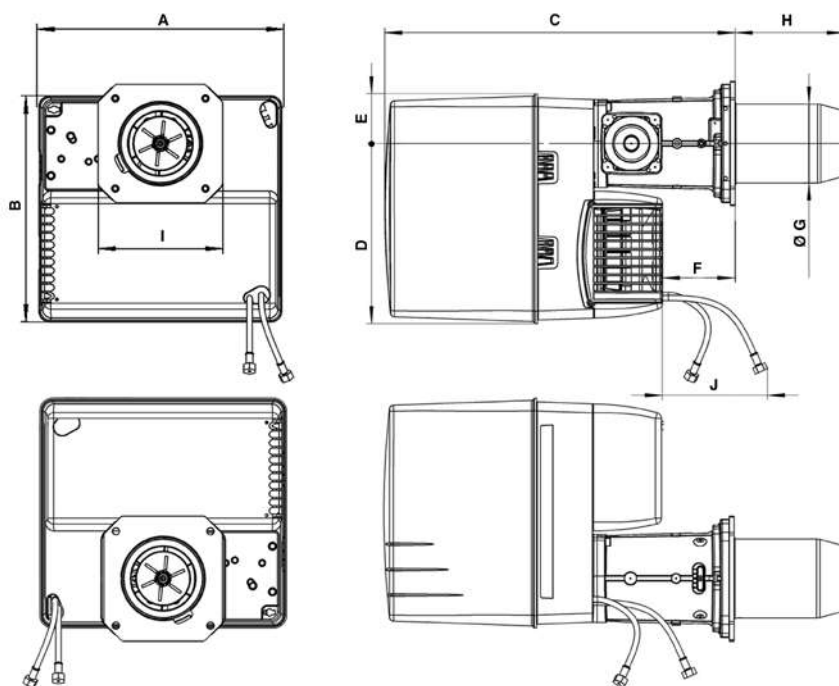

	A	B	C	D	E	F	ØG	H		I	J
								KN	KL		
<b>VL3</b>	406	379	576	297	82	120	130	180	320	195x205	1000
<b>VL4</b>	465	475	640	377	97	149	150	220	360	245x245	1000

**Connecting flange**

	Øa (mm)	b (mm)	c	d
<b>VL3</b>	155-190	175-220	M10	45°
<b>VL4</b>	190-240	200-270	M10	45°

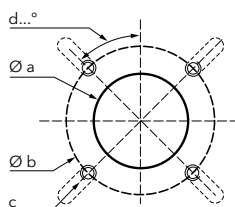

**PACKAGING**

The burner is delivered on a pallet in 2 packages containing:

- burner housing
- combustion head

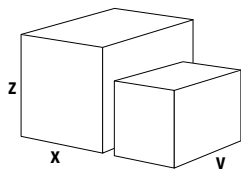

Component		Dimensions (mm)			Gross weight (kg)
		X	Y	Z	
Burner body	<b>VL3.290 D</b>	440	400	520	22
	<b>VL3.360 D</b>	440	400	520	23
	<b>VL4.440 D</b>	490	490	590	30
Combustion head	<b>VL3 (KN)</b>	650	210	260	6
	<b>VL3 (KL)</b>	780	210	260	7
	<b>VL4 (KN)</b>	750	260	295	8,5
	<b>VL4 (KL)</b>	895	260	295	9,7

**VL4.460 D, VL4.610 D**

180 ... 610 kW

2 stages

- **Fuel:** light oil (viscosity 6 mm<sup>2</sup>/s at 20°C, H<sub>u</sub> = 11,86 kWh/kg)
- **Emissions:** Low NO<sub>x</sub> class 2 (≤185 mg/kWh) according to EN267
- **Protection level:** IP 41



**TECHNICAL DATA**

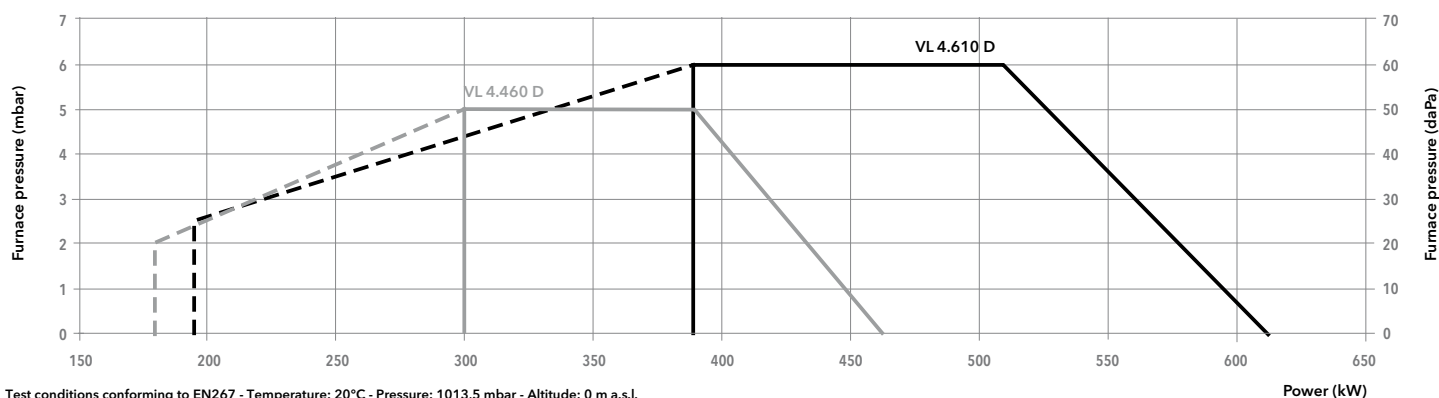

Test conditions conforming to EN267 - Temperature: 20°C - Pressure: 1013,5 mbar - Altitude: 0 m a.s.l.

Model	VL4.460 D		VL4.610 D	
Operation range	(180) 300 - 460 kW		(195) 390 - 610 kW	
Fuel flow	(15,2) 25,3 - 38,8 kg/h		(16,4) 32,9 - 51,4 kg/h	
Nozzles	5,00 US gal/h 60°S / 3,5 US gal/h 60°S		6,50 US gal/h 60°S / 3,00 US gal/h 60°S	
Control box / flame detection	TCH2... / QRB1		TCH2... / QRB1	
Fan motor	230 V - 50 Hz - 420 W		230 V - 50 Hz - 750 W	
Electrical consumption	545 W		830 W	
Flexible hoses	Rp 3/8" / DN6 x 1500 mm		Rp 3/8" / DN6 x 1500 mm	
Acoustic level (LpA)	70 dB(A)		71 dB(A)	
Head lenght	KN	KL	KN	KL
Complete burner code	3833395	3833396	3833397	3833398

**OTHER AVAILABLE VERSIONS**

Versions for continuous ventilation and post-ventilation

**SCOPE OF SUPPLY**

The burner is delivered in its package complete with:

- 1 burner head with flange seal and securing screws
- 1 bag containing installation fittings
- 1 bag containing technical documentation (instruction manual, technical data, electrical diagram, exploded view and spare parts list)

DIMENSIONS (mm)

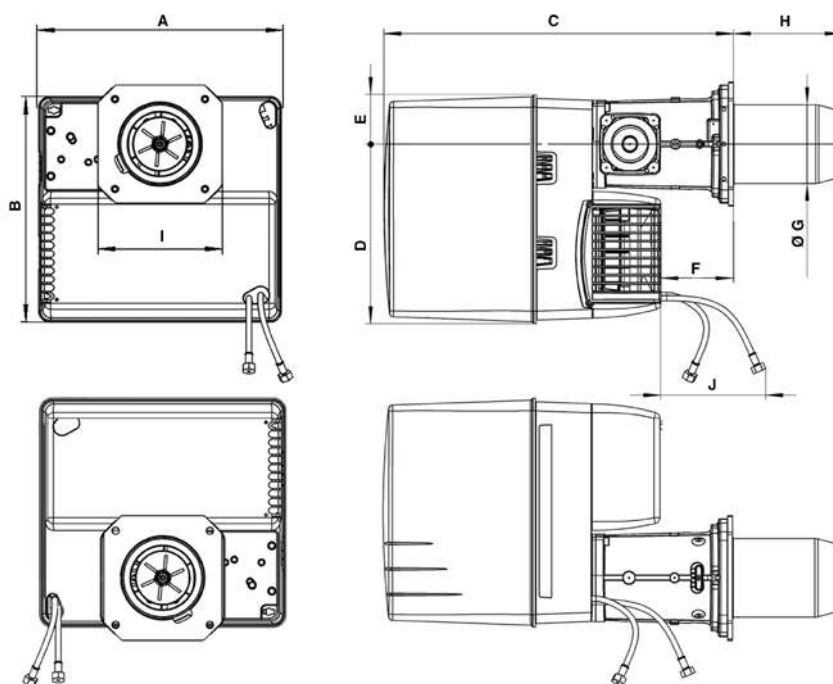

A	B	C	D	E	F	ØG	H		I	J
							KN	KL		
465	475	640	377	97	149	150	220	360	245	1000

Connecting flange

Øa (mm)	b (mm)	c	d
180-240	200-270	M10	45°

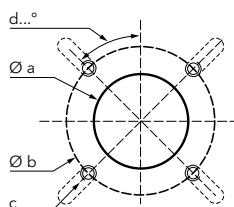

PACKAGING

The burner is delivered on a pallet in 2 packages containing:

- burner housing
- combustion head

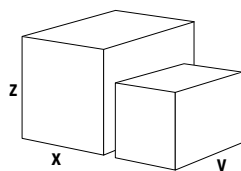

Component		Dimensions (mm)			Gross weight (kg)
		X	Y	Z	
Burner body	VL4.460 D	490	490	590	30
	VL4.610 D	490	490	590	34,2
Combustion head	KN	750	260	295	8,5
	KL	895	260	295	9,7

## VL5.950 D, VL5.1200 D

260 ... 1186 kW  
2 stages

- **Fuel:** light oil (viscosity 6 mm<sup>2</sup>/s at 20°C, H<sub>u</sub> = 11,86 kWh/kg)
- **Emissions:** Low NO<sub>x</sub> class 2 (≤185 mg/kWh) according to EN267
- **Protection level:** IP 21



### TECHNICAL DATA

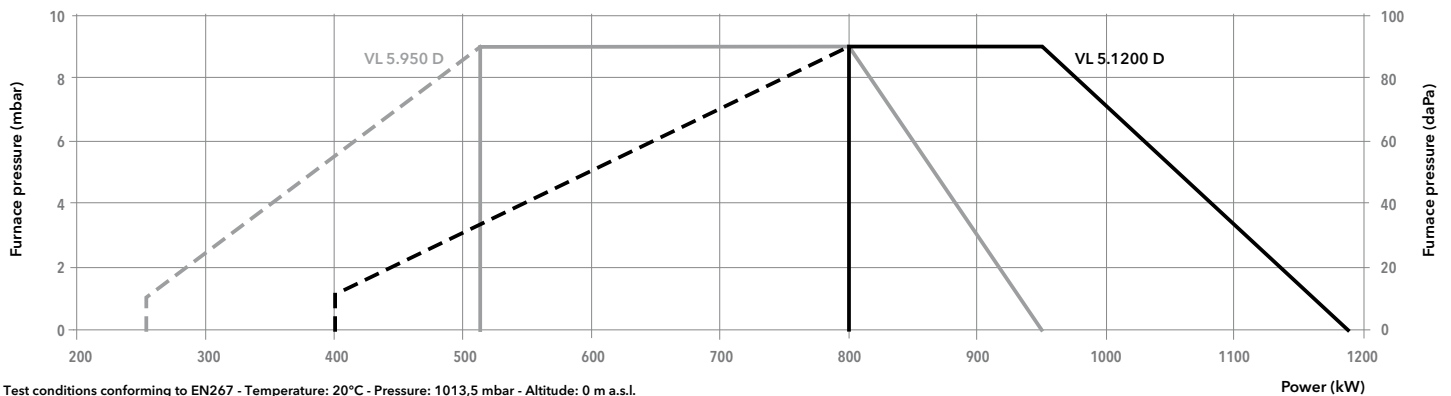

Model	VL5.950 D			VL5.1200 D		
Operation range	(260) 510 - 950 kW			(400) 800 - 1186 kW		
Fuel flow	(21,9) 43 - 80,1 kg/h			(33,7) 67,5 - 100 kg/h		
Nozzles	7,50 + 6,50 US gal/h			8,50 + 7,50 US gal/h		
Control box / flame detection	TCH2... / QRB1			TCH2... / QRB1		
Fan motor	230 V - 50 Hz - 1,5 kW			230 V - 50 Hz - 1,5 kW		
Electrical consumption	160 + 1700 W			155 + 1940 W		
Flexible hoses	Rp 3/8" / M16 x 1,5 - 1500 mm			Rp 3/8" / M16 x 1,5 - 1500 mm		
Acoustic level (LpA)	70 dB(A)			71 dB(A)		
Head lenght	KN	KL	KM	KN	KL	KM
Complete burner code	3833501	3833504	3833613	3833502	3833503	3833614

### OTHER AVAILABLE VERSIONS

 Versions for continuous ventilation and post-ventilation

### SCOPE OF SUPPLY

The burner is delivered in its package complete with:

- 1 burner head with flange seal and securing screws
- 1 bag containing installation fittings
- 1 bag containing technical documentation (instruction manual, technical data, electrical diagram, exploded view and spare parts list)

**DIMENSIONS (mm)**

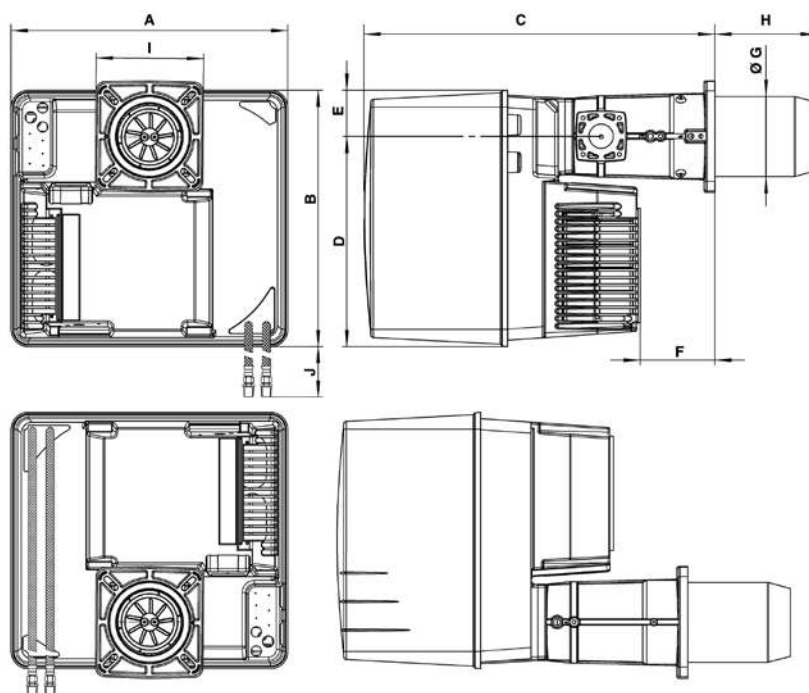

A	B	C	D	E	F	ØG	H			I	J
							KN	KM	KL		
581	549	752	450	99	164	170	215	325	435	230x238	950

**Connecting flange**

Øa (mm)	b (mm)	c	d
195	220-260	M10	45°

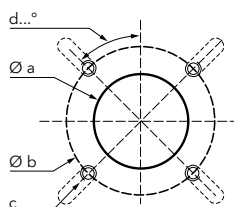

**PACKAGING**

The burner is delivered on a pallet in 2 packages containing:

- burner housing
- combustion head

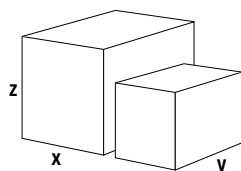

Component		Dimensions (mm)			Gross weight (kg)
		X	Y	Z	
Burner body	VL5.950 D	800	600	850	58,8
	VL5.1200 D	800	600	850	58,6
Combustion head	VL5.950 (KN)	780	265	280	10
	VL5.950 (KL)	1010	265	280	13,5
	VL5.950 (KM)	1010	265	280	12,5
	VL5.1200 (KN)	780	265	280	10,1
	VL5.1200 (KL)	1010	265	280	13,5
	VL5.1200 (KM)	1010	265	280	12

## VL4.460 DP, VL4.610 DP

180 ... 610 kW

3 stages

- **Fuel:** light oil (viscosity 6 mm<sup>2</sup>/s at 20°C, H<sub>u</sub> = 11,86 kWh/kg)
- **Emissions:** Low NO<sub>x</sub> class 2 (≤185 mg/kWh) according to EN267
- **Protection level:** IP 41



### TECHNICAL DATA

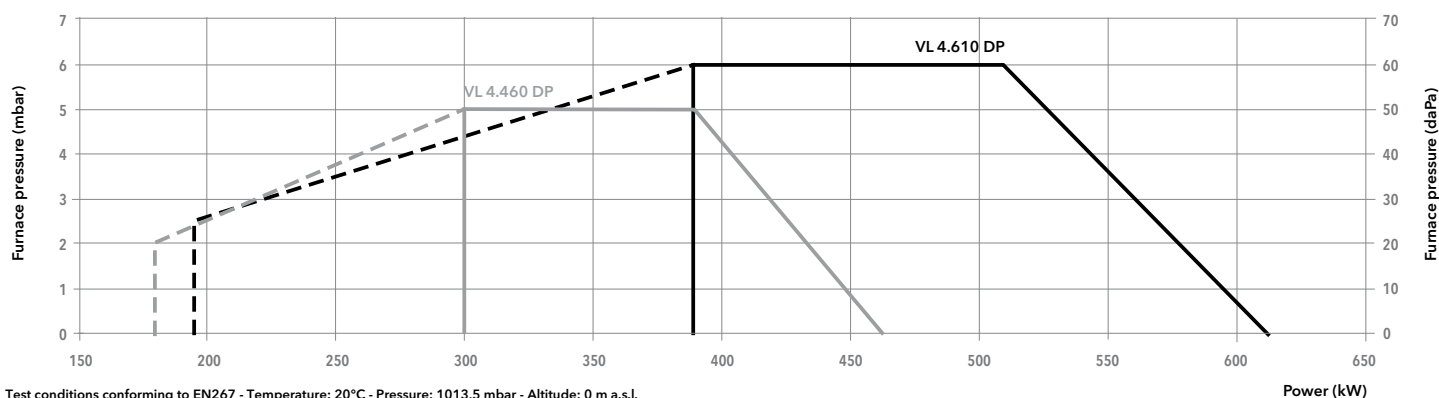

Model	VL4.460 DP		VL4.610 DP	
Operation range	(180) 300 - 460 kW		(195) 390 - 610 kW	
Fuel flow	(15,2) 25,3 - 38,8 kg/h		(16,4) 32,9 - 51,4 kg/h	
Nozzles	4,00 + 2,50 US gal/h		4,50 + 3,00 US gal/h	
Control box / flame detection	TCH2... / QRB1		TCH2... / QRB1	
Fan motor	230 V - 50 Hz - 420 W		230 V - 50 Hz - 750 W	
Electrical consumption	545 W		830 W	
Flexible hoses	Rp 3/8" / DN6 x 1500 mm		Rp 3/8" / DN6 x 1500 mm	
Acoustic level (LpA)	70 dB(A)		71 dB(A)	
Head lenght	KN	KL	KN	KL
Complete burner code	3833968	3833969	3833970	3833971

### OTHER AVAILABLE VERSIONS

Versions for continuous ventilation and post-ventilation

### SCOPE OF SUPPLY

The burner is delivered in its package complete with:

- 1 burner head with flange seal and securing screws
- 1 bag containing installation fittings
- 1 bag containing technical documentation (instruction manual, technical data, electrical diagram, exploded view and spare parts list)



DIMENSIONS (mm)

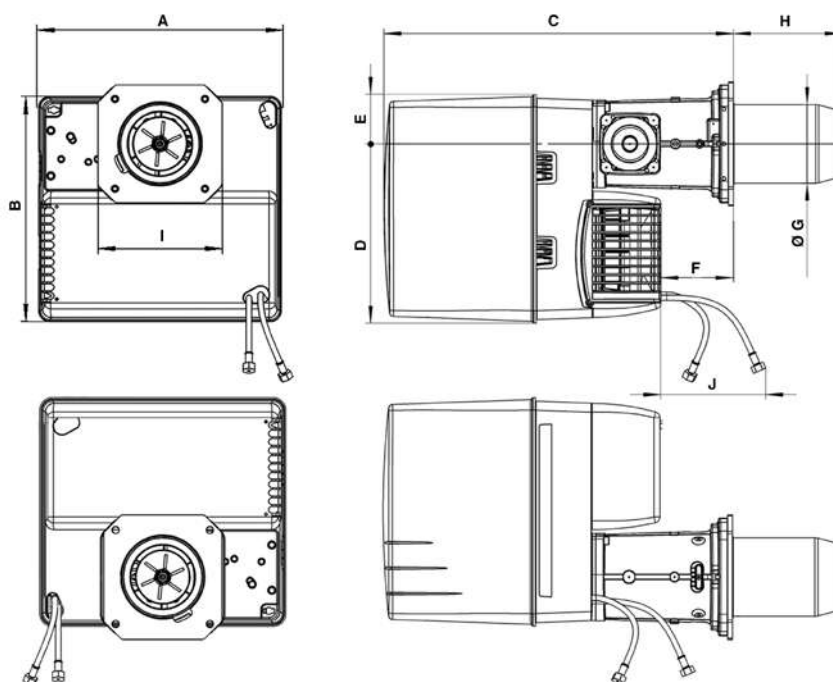

A	B	C	D	E	F	ØG	H		I	J
							KN	KL		
465	475	640	377	97	149	150	220	360	245	1000

Connecting flange

Øa (mm)	b (mm)	c	d
180-240	200-270	M10	45°

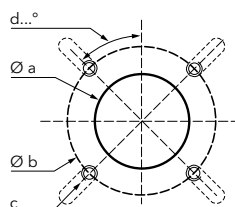

PACKAGING

The burner is delivered on a pallet in 2 packages containing:

- burner housing
- combustion head

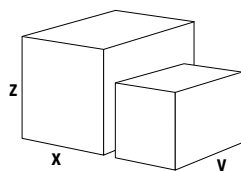

Component		Dimensions (mm)			Gross weight (kg)
		X	Y	Z	
Burner body	VL4.460 DP	490	490	590	30
	VL4.610 DP	490	490	590	34,2
Combustion head	KN	750	260	295	8,5
	KL	895	260	295	9,7

## VL5.950 DP, VL5.1200 DP

260 ... 1186 kW  
3 stages

- **Fuel:** light oil (viscosity 6 mm<sup>2</sup>/s at 20°C, H<sub>u</sub> = 11,86 kWh/kg)
- **Emissions:** Low NO<sub>x</sub> class 2 (≤185 mg/kWh) according to EN267
- **Protection level:** IP 21



### TECHNICAL DATA

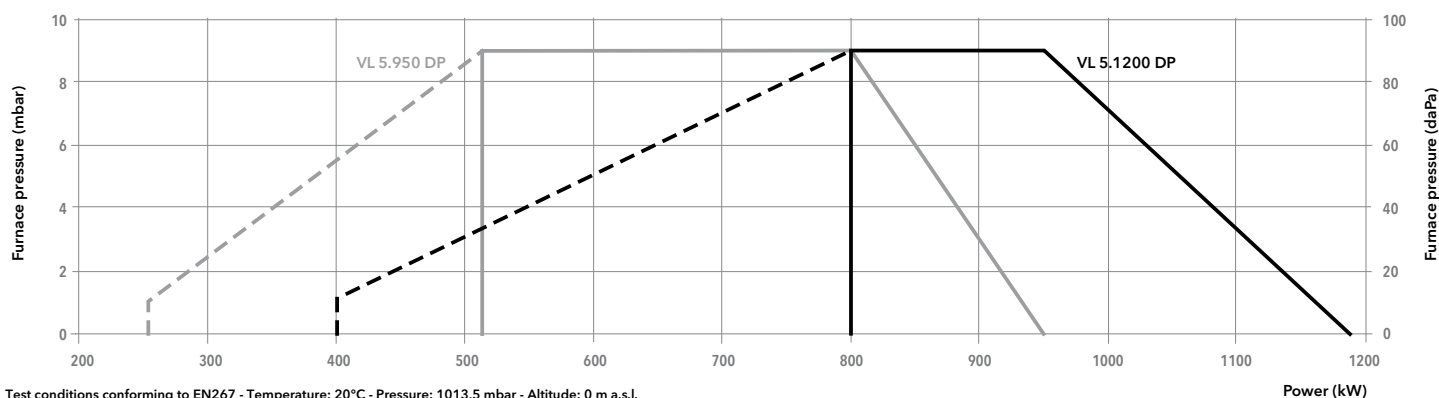

Model	VL5.950 DP			VL5.1200 DP		
Operation range	(260) 510 - 950 kW			(400) 800 - 1186 kW		
Fuel flow	(21,9) 43 - 80,1 kg/h			(33,7) 67,5 - 100 kg/h		
Nozzles	7,50 + 6,50 US gal/h			8,50 + 7,50 US gal/h		
Control box / flame detection	TCH2... / QRB1			TCH2... / QRB1		
Fan motor	230/400 V - 50 Hz - 1,5 kW			230/400 V - 50 Hz - 1,5 kW		
Electrical consumption	160 + 1700 W			155 + 1940 W		
Flexible hoses	Rp 3/8" / M16 x 1,5 - 1500 mm			Rp 3/8" / M16 x 1,5 - 1500 mm		
Acoustic level (LpA)	70 dB(A)			71 dB(A)		
Head lenght	KN	KL	KM	KN	KL	KM
Complete burner code	3833956	3833957	3833958	3833959	3833960	3833961

### OTHER AVAILABLE VERSIONS

 Versions for continuous ventilation and post-ventilation

### SCOPE OF SUPPLY

The burner is delivered in its package complete with:

- 1 burner head with flange seal and securing screws
- 1 bag containing installation fittings
- 1 bag containing technical documentation (instruction manual, technical data, electrical diagram, exploded view and spare parts list)

**DIMENSIONS (mm)**

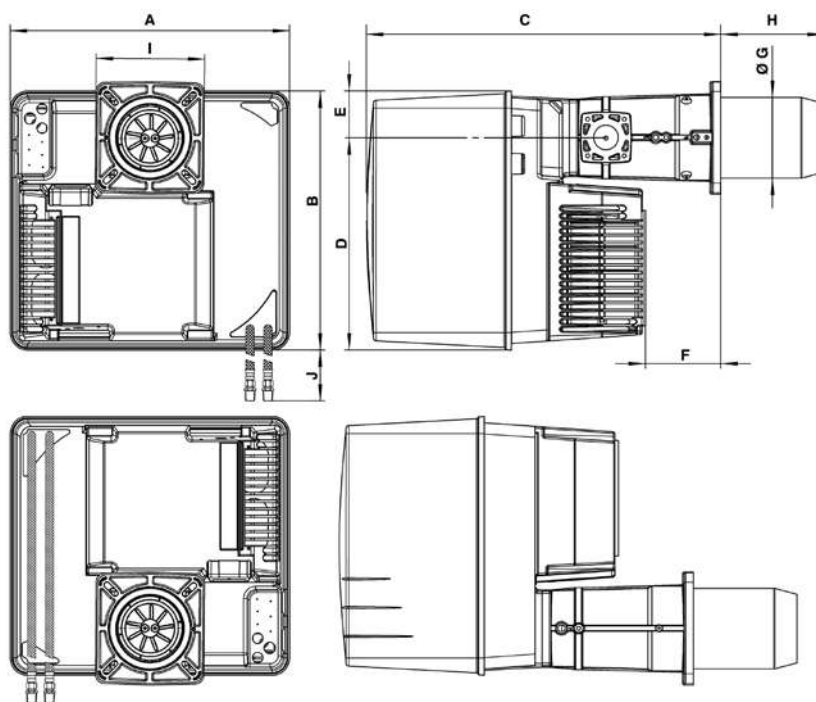

A	B	C	D	E	F	ØG	H			I	J
							KN	KM	KL		
581	549	752	450	99	164	170	215	325	435	230 x 238	950

**Connecting flange**

Øa (mm)	b (mm)	c	d
195	220-260	M10	45°

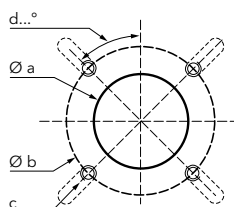

**PACKAGING**

The burner is delivered on a pallet in 2 packages containing:

- burner housing
- combustion head

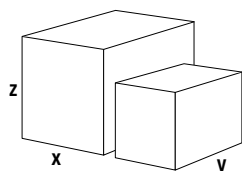

Component		Dimensions (mm)			Gross weight (kg)
		X	Y	Z	
Burner body	VL5.950 DP	800	600	850	58,8
	VL5.1200 DP	800	600	850	58,6
Combustion head	VL5.950 (KN)	780	265	280	10
	VL5.950 (KL)	1010	265	280	13,5
	VL5.950 (KM)	1010	265	280	12,5
	VL5.1200 (KN)	780	265	280	10,1
	VL5.1200 (KL)	1010	265	280	13,5
	VL5.1200 (KM)	1010	265	280	12

**VL6.1600 DP, VL6.2100 DP**

320 ... 2080 kW  
3 stages

- **Fuel:** light oil (viscosity 6 mm<sup>2</sup>/s at 20°C, H<sub>u</sub> = 11,86 kWh/kg)
- **Emissions:** Low NO<sub>x</sub> class 2 (≤185 mg/kWh) according to EN267
- **Protection level:** IP 21



**TECHNICAL DATA**

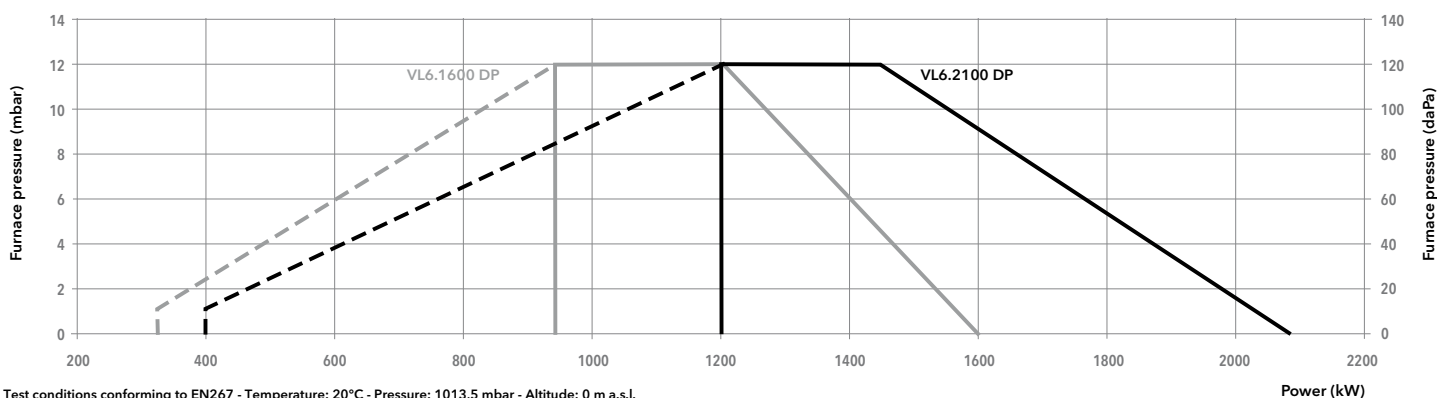

Model	VL6.1600 DP			VL6.2100 DP		
Operation range	(320) 950 - 1600 kW			(400) 1200 - 2080 kW		
Fuel flow	(27) 80,1 - 124,9 kg/h			(33,7) 101,2 - 177 kg/h		
Nozzles	3 x 6,50 US gal/h			3 x 8,50 US gal/h		
Control box / flame detection	TCH3... / QRB1			TCH3... / QRB1		
Fan motor	230/400 V - 50 Hz - 2,2 kW			230/400 V - 50 Hz - 2,7 kW		
Electrical consumption	352 + 2240 W			380 + 2840 W		
Flexible hoses	Rp 1/2" / M16 x 1,5 - 1500 mm			Rp 1/2" / M16 x 1,5 - 1500 mm		
Acoustic level (LpA)	78,1 dB(A)			79,3 dB(A)		
Head lenght	KN	KL	KM	KN	KL	KM
Complete burner code	3833694	3833695	3833696	3833697	3833698	3833699

**OTHER AVAILABLE VERSIONS**

Versions for continuous ventilation and post-ventilation

**SCOPE OF SUPPLY**

The burner is delivered in its package complete with:

- 1 burner head with flange seal and securing screws
- 1 bag containing installation fittings
- 1 bag containing technical documentation (instruction manual, technical data, electrical diagram, exploded view and spare parts list)

DIMENSIONS (mm)

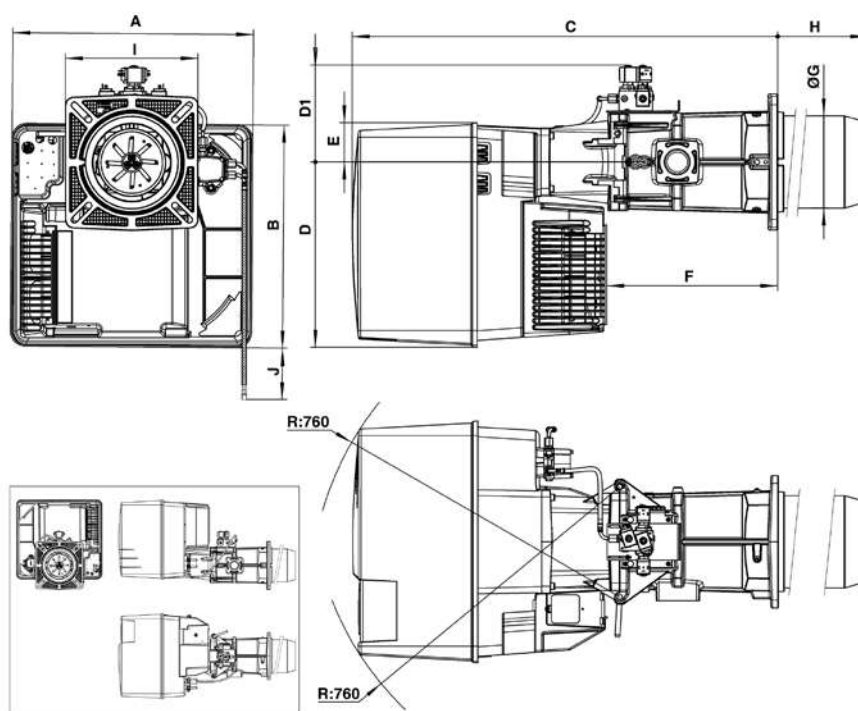

A	B	C	D	D1	E	F	ØG	H			I	J
								KN	KM	KL		
592	553	1050	456	239	97	421	227	270	370	470	326x335	950

Connecting flange

Øa (mm)	b (mm)	c	d
250	300-400	M12	45°

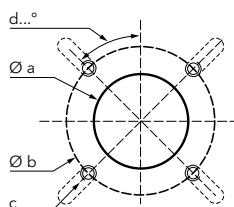

PACKAGING

The burner is delivered on a pallet in 2 packages containing:

- burner housing
- combustion head

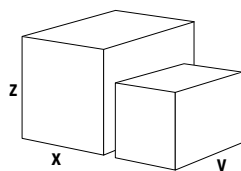

Component		Dimensions (mm)			Gross weight (kg)
		X	Y	Z	
Burner body	VL6.1600 DP	800	600	850	79,4
	VL6.2100 DP	800	600	850	79,6
Combustion head	VL6.1600 (KN)	800	380	420	42
	VL6.1600 (KL)	1000	420	380	29,8
	VL6.1600 (KM)	1000	420	380	28,3
	VL6.2100 (KN)	800	380	420	24
	VL6.2100 (KL)	1000	380	420	42
	VL6.2100 (KM)	1000	380	420	42

## MODULATION KIT

A modulating burner allows to adapt the power delivered according to the boiler/system requirements. To obtain the modulating operation the installation of a power regulator and the relative temperature or pressure probes, chosen in accordance with the specific requirements of the installation.

To simplify the selection of regulator and probes ELCO offers specific kits. Alternatively, the customer can request the individual components.

### Kit RWF50 with sensor

Description	Burners	Code
Kit GEP130 (water - immersion probe)	V2	3834039
Kit GEA130 (water - strap-on probe)	V2	3834040
Kit IEP130 (water - immersion probe)	V3	3834043
Kit IEA130 (water - strap-on probe)	V3	3834044
Kit LEP130 (water - immersion probe)	V4	3834047
Kit LEA130 (water - strap-on probe)	V4	3834048
Kit MEP130 (water - immersion probe)	V5 and V6	3834049
Kit MEA130 (water - strap-on probe)	V5 and V6	3834050
MIF001R (kit mounted in factory)	V2 to V6	on request



#### Example:

Kit with immersion probe with working field limitation up to 130°C for water tube boiler, mounted in factory on a VG2.210 D

Kit GEP130  
(water - immersion probe)  
3834039

+

MIF001R  
(kit mounted  
in factory)

### Kit RWF55 with sensor

Description	Burners	Code
Kit LEP 130 (water - immersion sensor)	V5 and V6	3834602
Kit LEA 130 (water - strap-on probe)	V5 and V6	3834603
Kit LVA 16 (steam - pressure probe)	V5 and V6	3834604
Acc AQE21.02 (kit for using Kit LEP 130 on hot air generator)	V5 and V6	3834307
MIF001R (kit mounted in factory)	V5 and V6	on request



#### Example:

Kit with pressure probe for steam boiler, mounted in factory on a VG5.950 DP

Kit LVA 16  
(steam - pressure probe)  
3834604

+

MIF001R  
(kit mounted  
in factory)

**RWF50 stand-alone and wiring kit**

Description	Burners	Code
Load controller RWF50 SA	V2 to V6	3833498
Wiring kit RWF50 EW03	V2	3834056
Wiring kit RWF50 EW04	V3	3834057
Wiring kit RWF50 EW05	V4	3834058
Wiring kit RWF50 W06-07	V5 and V6	3834032

**Example:**

Power regulator RWF50 for VG3.360 DP and wiring kit

 Load controller  
**RWF50 SA**  
 3833498

+

 Wiring kit  
**RWF50 EW04**  
 3834057

**RWF55 stand-alone and wiring kit**

Description	Burners	Code
Load controller RWF55 SA*	V5 and V6	3834298
Wiring kit RWF55 W06-07*	V5 and V6	3834299



\*: for VGL5 and VGL6 the RWF55 can be ordered but it must be installed in our factory

**Example:**

Power regulator RWF55 for VG5.1200 DP and wiring kit

 Load controller  
**RWF55 SA**  
 3834298

+

 Wiring kit  
**RWF55 W06-07**  
 3834299

**Separated sensors**

Description	Burners	Code
Acc TIP 130 (Immersion probe, water 130°C)	V2 to V6	3833163
Acc TSP 130 (Strap-on probe, water 130°C)	V2 to V6	3833165
Acc TIP 400 (Hot water/air probe Pt100 / 400°C - L = 160 mm)	V2 to V6	65300274
Acc QBE2002-P1 (0 ... 1 bar)	V2 to V6	3834310
Acc QBE2002-P2 (0 ... 2 bar)	V2 to V6	3834311
Acc QBE2002-P4 (0 ... 4 bar)	V2 to V6	3834312
Acc QBE2002-P10 (0 ... 10 bar)	V2 to V6	3834313
Acc QBE2002-P16 (0 ... 16 bar)	V2 to V6	3834305
Acc QBE2002-P25 (0 ... 25 bar)	V2 to V6	3834314
Acc QBB22.1 (QBE sensor support)	V2 to V6	3834309
Acc QBB2001 (1 meter connection pipe)	V2 to V6	3834308
Acc QAC22 (external probe)	V2 to V6	13018513



## O<sub>2</sub> TRIM for BT3xx

This device optimizes the combustion in order to keep the air excess as much stable as possible irrespective of the changings that can occur during operations, for instance slight calorific value variations, combustion air temperature and pressure. This improves the seasonal efficiency and therefore reduces the fuel consumption.

The kit includes all the fittings for the installation. Main components are:

- control unit with display;
- probe;
- intake pipe to be fixed to the stack (choose the proper length).

The control unit has to be installed close to the probe (max 20 m of cable)

The probe needs a calibration but no reference gas is necessary.

The display shows the O<sub>2</sub> content.

Maximum distance between the control unit and the burner control panel is 500 m.

Description	Output	Probe length	Code
<b>Kit for O<sub>2</sub> trim (LT3 + LS2) - Flue temp max 300 °C - display for O<sub>2</sub> visualization</b> (Note: for models equipped with BT3xx this kit needs a LCM module installed in the burner control panel)	1 x 4-20 mA	150 mm	<b>3757433</b>
	1 x 4-20 mA	300 mm	<b>3757137</b>
	1 x 4-20 mA	450 mm	<b>3757138</b>

## O<sub>2</sub> TRIM with CO measure for BT3xx

This device optimizes the combustion in order to keep the air excess as low as possible in order to maximize the seasonal efficiency and therefore minimize the fuel consumption.

In addition to the features of the O<sub>2</sub> trim only, this kit reduces the air excess to its minimum because this system continuously measures the CO content in the flue: should the air excess be reduced too much, the CO raises and the system reacts by increasing the air excess in order to keep firing in safe conditions.

The kit includes all the fittings for the installation. Main components are:

- control unit with display;
- probe;
- intake pipe to be fixed to the stack (choose the proper length).

The control unit has to be installed close to the probe (max 20 m of cable).

The probe needs a calibration but no reference gas is necessary.

The display shows the O<sub>2</sub> content.

Maximum distance between the control unit and the burner control panel is 500 m.

Description	Output	Probe length	Code
<b>Kit for O<sub>2</sub> trim and CO control (LT3-F + KS1D) - Flue temp max 300 °C</b> (Note: for models equipped with BT3xx this kit needs a LCM module installed in the burner control panel)	None	150 mm	<b>3758001</b>
	None	300 mm	<b>3755046</b>
	None	450 mm	<b>3756533</b>

## Kit LCM for BT3xx

Description	Burners	Code
<b>Analog input and output (chosen among 0-10 V and 4-20 mA) (Module built-in)</b>	V2 M to V6 M	<b>3836239</b>

## Remote software

Description	Burners	Code
<b>Kit to connect a PC laptop to BT3xx for its parametrization (LSA100 + USB/CAN + cd-rom)</b>	V2 M to V6 M	<b>3751130</b>



**MDE2 System**

Description	Burners	Code
PC interface tool to connect the control box to a personal computer allowing transmission of burner operation data, fault signals and service information	V1 and V2	3833018

**Cable for 0-10V load input <sup>(1)</sup> (applicable to Ariston TCG2/TCH2 or higher)**

Description	Burners	Code
Kit 0-10V BCU/0	V2 to V6	3834253

<sup>(1)</sup>: the 0-10 V must be exchanged with a device with the electric feeding shared with the burner. On the contrary a galvanic separator (code 3144698) must be fitted

**Cable for 0-10V load input <sup>(1)</sup> + potentiometer for actuator position feedback (applicable to Ariston TCG2/TCH2 or higher)**

Description	Burners	Code
Kit 0-10V BCU/1	V2, V3, V4	3834170
Kit 0-10V BCU/2	V5, V6	3834171

<sup>(1)</sup>: the 0-10 V must be exchanged with a device with the electric feeding shared with the burner. On the contrary a galvanic separator (code 3144698) must be fitted

**Analog signal converter and galvanic separator <sup>(2)</sup> (applicable to Ariston TCG2/TCH2 or higher)**

Description	Burners	Code
Conversion among 0-10 V, 4-20 mA, 0-20 mA signals	V2 to V6	3144698

<sup>(2)</sup>: all the items provided with the code 3834253 are already included in this kit

**Sound proofing box - noise reduction 15...20 dB(A)**

Description	Burners	Code
CI20	V2	on request
CI21	V3	on request
CI22	V4	on request
CI23	V5	on request
CI24	V6	on request

**Sound proofing box - noise reduction 20...30 dB(A)**

Description	Burners	Code
CI31	V3	on request
CI32	V4	on request
CI33	V5	on request
CI34	V6	on request

**Front boiler flange**

Description	Burners	Code
CP1	V1	13018495
CP2	V2	13018496
CP3.1	V3	3833151
CP4	V4 and V5	13018499
CP5.1	V6	13008019

**External air intake connection kit**

Description	Burners	Code
Kit RG4 (Ø 50mm, directable)	VB1.20 to V1.55	13004320
Kit RG9 (Ø 50)	VB1.20 to VB1.95	13011996
Kit RG10 (Ø 100)	V2	13018822
Kit RG11 (Ø 160)	V3	3833152
Kit RG12 (Ø 200)	V4	3833429
Kit RG3 (Ø 250)	V5 and V6	13014375

**Maximum gas pressure switch**

Description	Burners	Code
Kit for burners fitted with Artison BCU TCxx	V1 to V6	3833903
Kit for burners fitted with BT3xx	V2 M... to V6 M...	3836857

**Gas and air manometer with push button**

Description	Burners	Code
AGM 0-60mbar	All models	13002181
AGM 0-100mbar	All models	13018509
AGM 0-400mbar	All models	13018510

**Gas filter**

Description	Code
RP 15 - 1/2"	3141957
RP 20 - 3/4"	3142045
RP 25 - 1"	3142046
RP 40 - 1"1/2	3141954
RP 50 - 2"	3121384
DN 65 - 2"1/2	3124111
DN 80 - 3"	3142088
DN 100 - 4"	3142205
DN 125 - 5"	3142206

**Antivibration coupling - Compensator**

Description	Code
RP 1/2" threaded connection	3122321
RP 3/4" threaded connection	3122322
Rp 1" threaded connection	3122323
RP 1"1/4 threaded connection	3122324
Rp 1"1/2 threaded connection	3122325
Rp 2" threaded connection	3122326
DN50 flanged connection	12001014
DN65 flanged connection	3142060
DN80 flanged connection	3122328
DN100 flanged connection	3122329
DN125 flanged connection	3142061

**Ball valve**

Description	Code
Rp 1/2" threaded connection	3142000
Rp 3/4" threaded connection	3142254
Rp 1" threaded connection	3121430
Rp 1"1/4 threaded connection	3142253
Rp 1"1/2 threaded connection	3142101
Rp 2" threaded connection	3142102
DN65 flanged connection	3142062
DN80 flanged connection	3143730
DN100 flanged connection	3141997
DN125 flanged connection	3141998

**External valve connection kit**

Description	Burners	Code
Connector for safety solenoid valve	V1 to V4	13010959

**Kit Variatron**

Description	Burners	Code
Kit Variatron 1,5 KW	VG5 .950/1200 DP	3836887
Kit Variatron 2,2 KW	VG6.1600 DP	3836888
Kit Variatron 3 KW	VG6.2100 DP	3836889

**Kit remote reset**

Description	Burners	Code
Kit for burners fitted with Artison BCU TCxx	V1 to V6	13011486
Kit for burners fitted with BT3xx	V1 M... to V6 M...	3144622

**Kit additional oil safety valve**

Description	Burners	Code
Kit OSV 01/02/03	V1 and V2	3832706
Kit OSV 06	V5	3834195

**"Flame on" digital output (BT300)**

Description	Burners	Code
Kit ROS BT3	V2 M to V6 M	on request





## Filiales ELCO

### ALEMANIA

ELCO GmbH  
Dreieichstraße 10  
Mörfelden-Walldorf  
Tel.: +49 (0) 6105 287-287  
Fax: +49 (0) 6105 287-199

### PAÍSES BAJOS

Elco Burners B.V.  
Meerpaalweg, 1  
1332 BB Almere  
P.O. box 30048  
1303 AA Almere  
Tel. +31 088 69 573 11  
Fax +31 088 69 573 90

### FRANCIA

14, rue du Saule Trapu  
Parc d'activité du Moulin  
91882 Massy  
Tel. +33 01 60 13 64 64  
Fax +33 01 60 13 64 65

### SUIZA

Elcotherm AG  
Sarganserstrasse 100  
7324 Vilters  
Tel. +41 (0)81 725 25 25  
Fax +41 (0)81 723 13 59

### AUSTRIA

ELCO Austria GmbH  
Aredstraße 16 - 18  
2544 Leobersdorf  
Tel. +43 (0)2256 639 99 32  
Fax +43 (0)2256 644 11

### ITALIA

Via Roma, 64  
31023 Resana (TV)  
Tel. +39 0423 719500  
Fax +39 0423 719580

### REINO UNIDO E IRLANDA

Ariston Thermo UK Ltd  
Suite 3, The Crown House  
Blackpole East, Blackpole Road,  
Worcester WR3 8SG  
Tel. +44 01905 788010  
Fax +44 01905 788011

### RUSIA

Ariston Thermo RUS  
Eniseyskaya str. 1, bld 1,  
Office Center "LIRA" #438  
129344 Moscow  
Tel. +7 495 213 0300 #5700  
Fax +7 495 213 0302

### CHINA

Ariston Thermo (China) Co., Ltd.  
F/15, V-Capital Bldg  
No. 333 Xian Xia Road  
200336 Shanghai  
Tel. +86 21 6039 8691  
Fax +86 21 6039 8620



## PROYECTOS DE AHORRO ENERGÉTICO, S.L.

Avda. Pirineos, 31-Nave 5  
28703 S.S. de los Reyes  
Madrid (España)  
Tfno. +34 91 651 98 27

[www.proaener.es](http://www.proaener.es)  
[elco@proaener.es](mailto:elco@proaener.es)